

NOTE:
Please read all instructions
carefully before using this
product

Table of Contents

Safety Notice

Hardware Pack

Assembly Instruction

Parts List

Warranty

Ordering Parts

Model
AMZ-150BK

Retain This
Manual for
Reference

190627

**ASSEMBLY &
OWNER'S
MANUAL**

**CIRCUIT
FITNESS**

**Foldable Bike
AMZ-150BK**

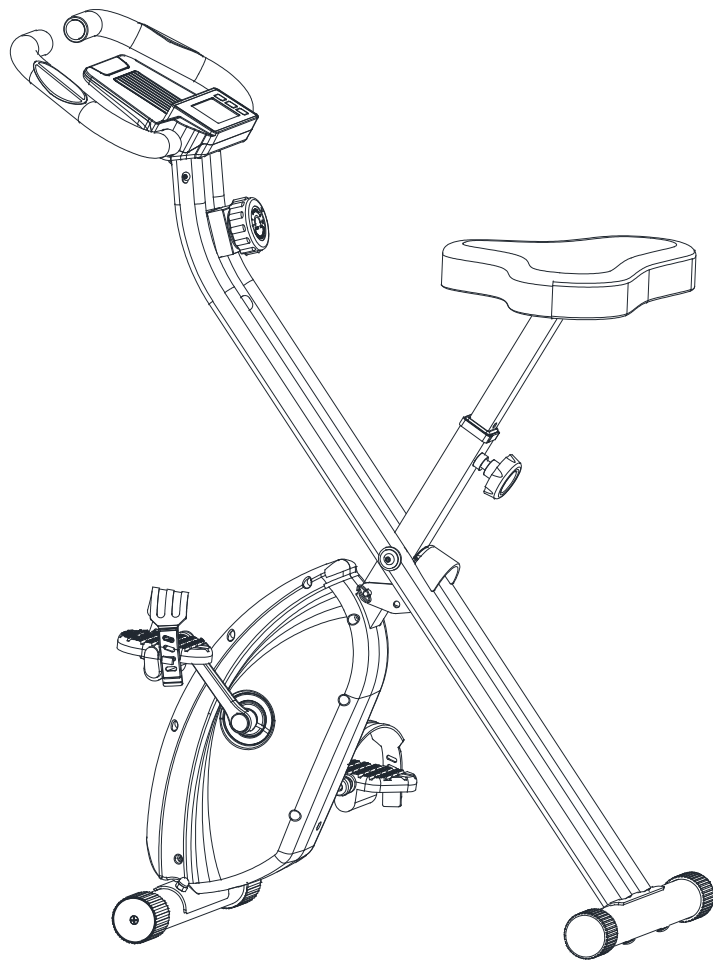

IMPEX® INC.

2801 S. Towne Ave, Pomona, CA 91766
Tel: (800) 999-8899 Fax: (626) 961-9966

www.marcypro.com

support@impex-fitness.com

TABLE OF CONTENTS

BEFORE YOU BEGIN	1
IMPORTANT SAFETY NOTICES	2
WARNING LABEL PLACEMENT	3
HARDWARE PACK	4
COMPONENT FOR ASSEMBLY	5
IMPORTANT ASSEMBLY INSTRUCTION	6
EXPLODED DIAGRAM	11
PARTS LIST	12
CARE AND MAINTENANCE, WEIGHT CAPACITY & DIMS.	12
COMPUTER	13
EXERCISE GUIDELINES	14
WARRANTY	16
ORDERING PARTS	16

BEFORE YOU BEGIN

Thank you for selecting the CIRCUIT FITNESS AMZ-150BK Foldable Bike by IMPEX® INC. For your safety and benefit, read this manual carefully before using the bike. As a manufacturer, we are committed to provide you complete customer satisfaction. If you have any questions, or find there are missing or damaged parts, we guarantee you complete satisfaction through direct assistance from our factory. To avoid unnecessary delays, *please call our TOLL-FREE customer service number*. Our Customer Service Agents will provide immediate assistance to you.

Toll-Free Customer Service Number

1-800-999-8899

Mon. - Fri. 9 a.m. - 5 p.m. PST

www.marcypro.com

support@impex-fitness.com

IMPORTANT SAFETY NOTICE

PRECAUTIONS

This exercise machine is built for optimum safety. However, certain precautions apply whenever you operate a piece of exercise equipment. Be sure to read the entire manual before you assemble or operate your machine. In particular, note the following safety precautions:

1. **Keep children and pets away from the machine at all times. DO NOT leave children unattended in the same room with the machine.**
2. Only one person at a time should use the machine.
3. If the user experiences dizziness, nausea, chest pain, or any other abnormal symptoms, STOP the workout at once. CONSULT A PHYSICIAN IMMEDIATELY.
4. Position the machine on a clear, leveled surface. DO NOT use the machine near water or outdoors.
5. Keep hands away from all moving parts.
6. Always wear appropriate workout clothing when exercising. DO NOT wear robes or other clothing that could become caught in the machine. Running or aerobic shoes are also required when using the machine.
7. Use the machine only for its intended use as described in this manual. DO NOT use attachments not recommended by the manufacturer.
8. Do not place any sharp object around the machine.
9. Disabled person should not use the machine without a qualified person or physician in attendance.
10. Before using the machine to exercise, always do stretching exercises to properly warm up.
11. Never operate the machine if the machine is not functioning properly.
12. Read all warnings posted on the exercise bike.
13. Inspect the exercise bike for worn or loose component prior to use. Tighten/replace any loose or wore components prior to use.
14. Care should be taken in mounting or dismounting the exercise bike.
15. **This exercise bike is for consumer and home use only.**

WARNING: BEFORE BEGINNING ANY EXERCISE PROGRAM, CONSULT YOUR PHYSICIAN. THIS IS ESPECIALLY IMPORTANT FOR INDIVIDUALS OVER THE AGE OF 35 OR PERSONS WITH PRE-EXISTING HEALTH PROBLEMS. READ ALL INSTRUCTIONS BEFORE USING ANY FITNESS EQUIPMENT. IMPEX INC. ASSUMES NO RESPONSIBILITY FOR PERSONAL INJURY OR PROPERTY DAMAGE SUSTAINED BY OR THROUGH THE USE OF THIS PRODUCT. SAVE THESE INSTRUCTIONS.

WARNING LABEL PLACEMENT

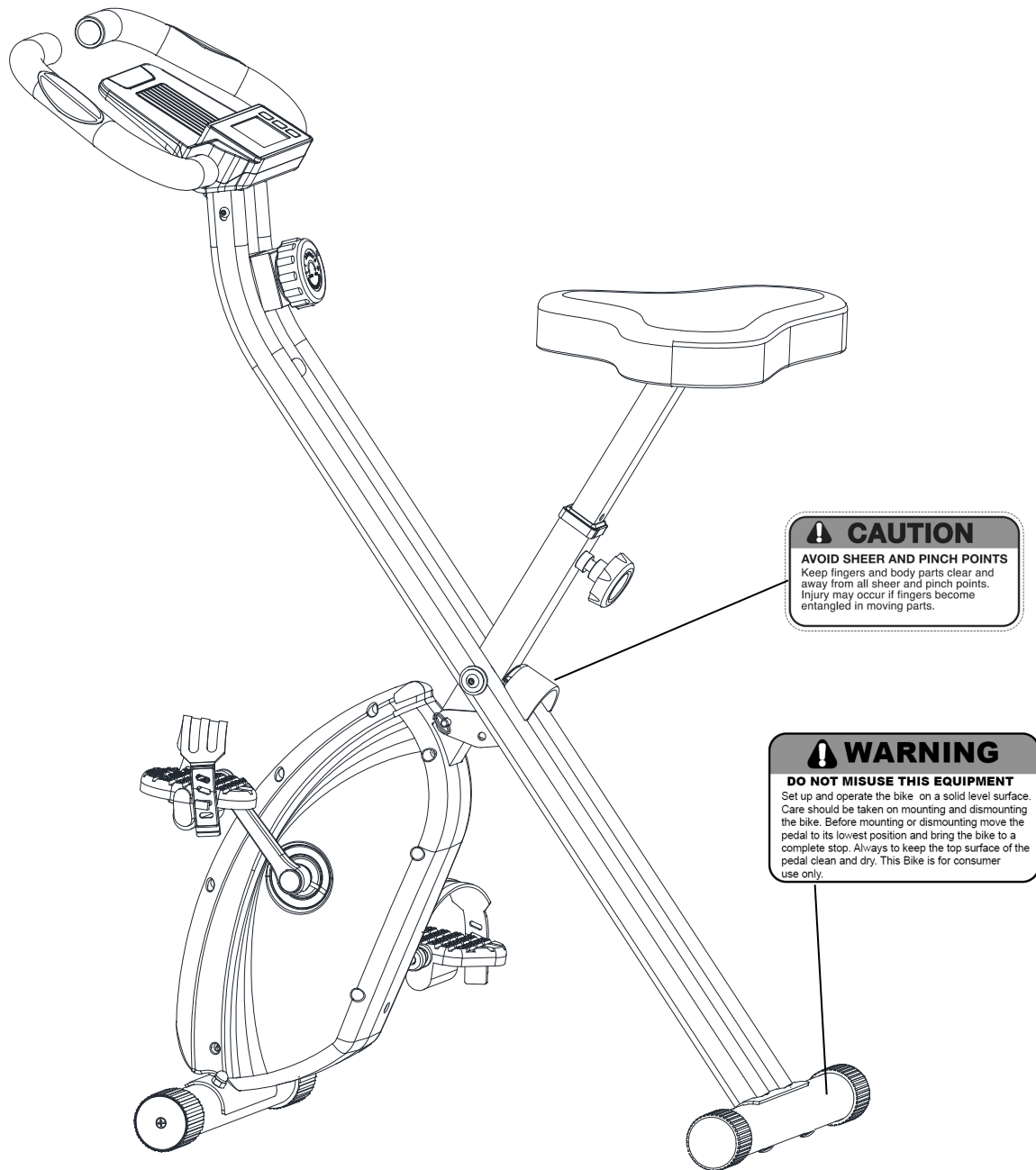

The Warning Labels shown here has been placed on the Front Stabilizer.
If the labels are missing or illegible, please call customer service at 1-800-999-8899 for replacement. Apply the labels in location shown.

HARDWARE PACK

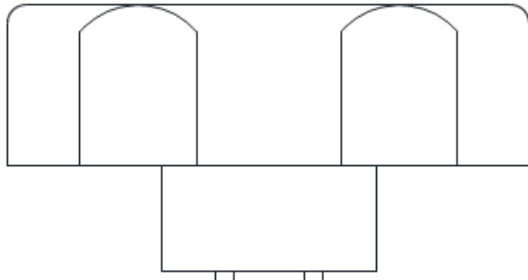

21
1X

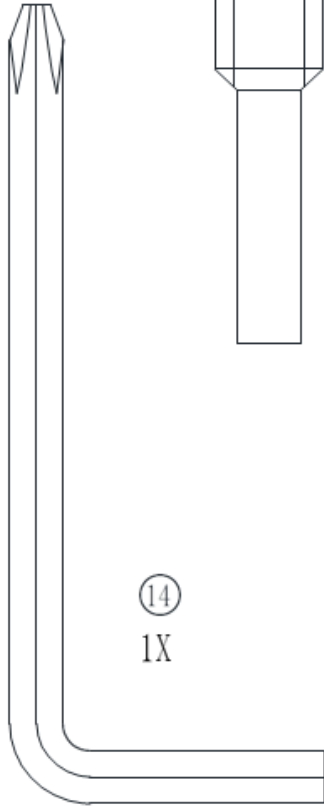
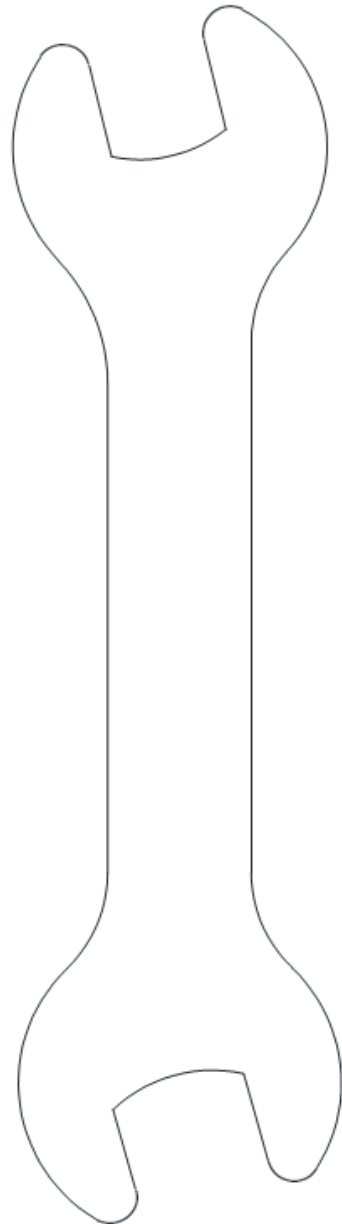

14
1X

10
1X

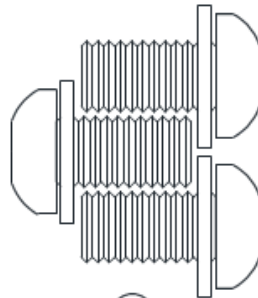

08
M8x $\frac{5}{8}$ "
3X

COMPONENTS FOR ASSEMBLY

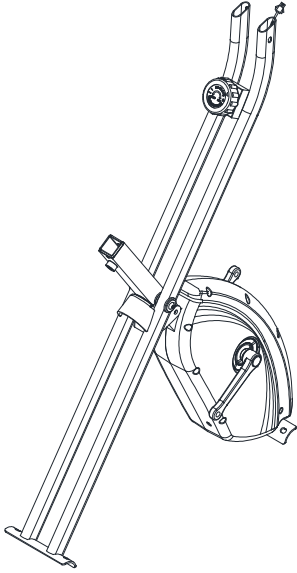

NO. 01/02

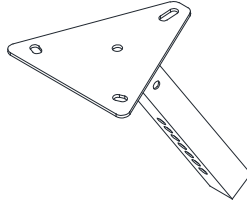

NO. 03

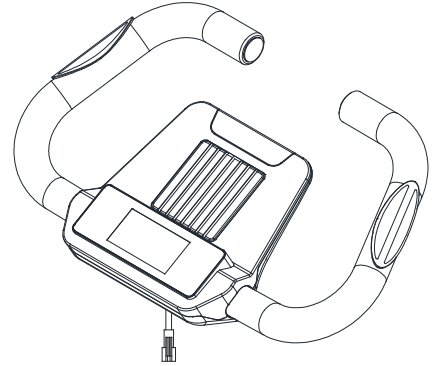

NO. 04

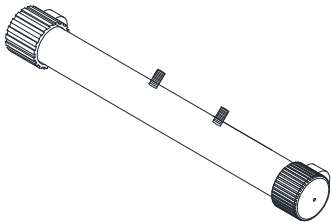

NO. 05

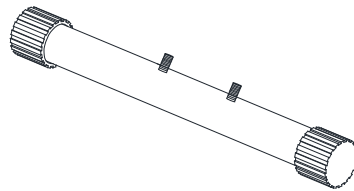

NO. 06

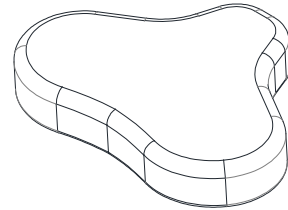

NO. 07

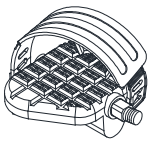

NO. 19



NO. 20

ASSEMBLY INSTRUCTION

- **Tools Required for Assembling the Machine: One Crossing Wrench and Allen Wrench, provided by manufacturer.**

STEP 1

- Remove the Domed Nut (#15), Curved Washer (#16) from the Front Stabilizer Support (#5) and Rear Stabilizer Support (#6).
- Pull the Safety-Pin (#18) from the Main Frame (#1).
- Pull the upright frame and the seat post apart and insert back the Safety-Pin to securely lock the Main frame in X-position.
- Attach the Front Stabilizer (#5) and Rear Stabilizer (#6) to the Main Frame (#1). Secure with Domed Nuts (#15) and Curved Washers (#16).

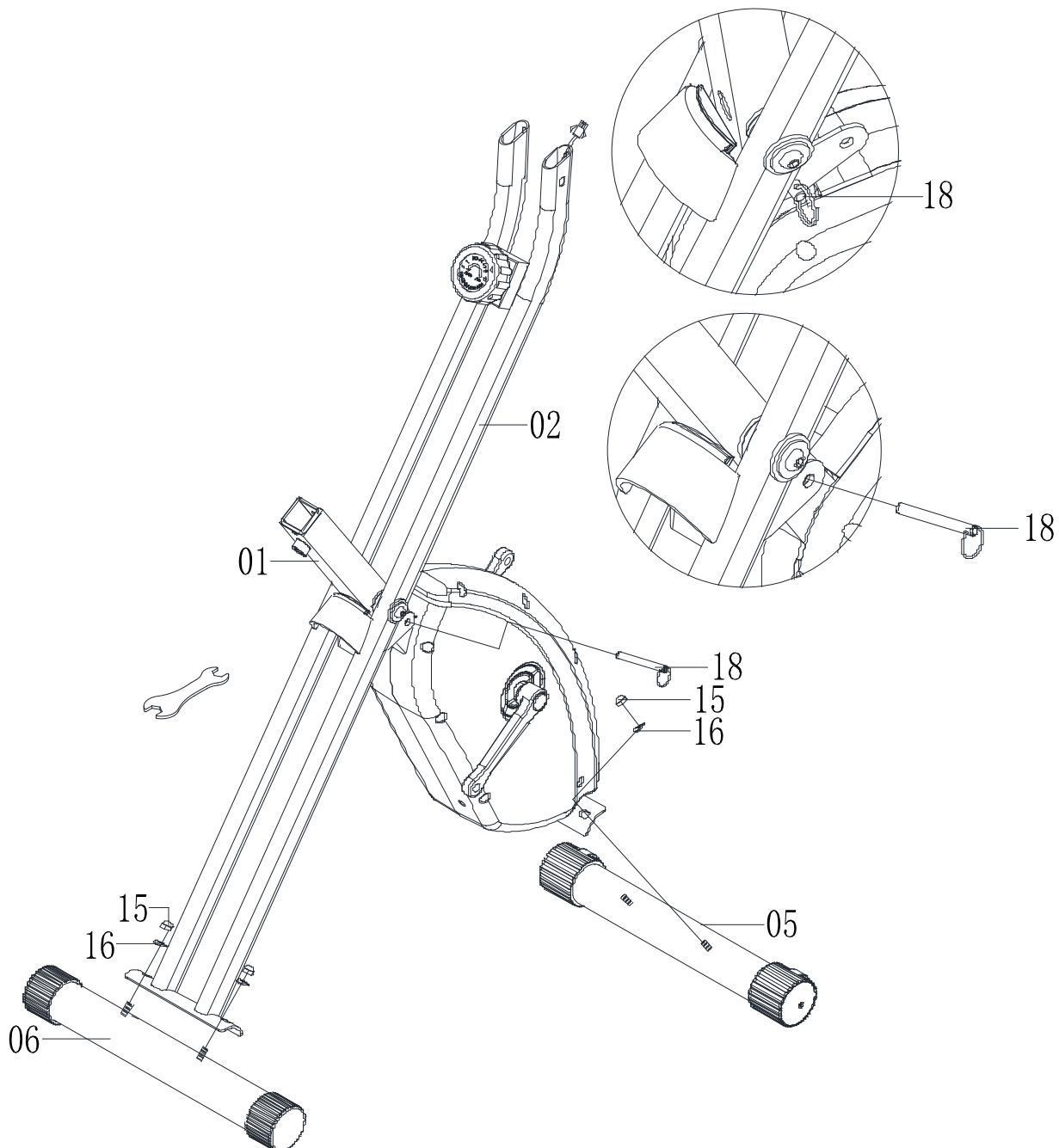

STEP 2

- A. Attach the strap (L) with the left pedal (#19) and latch the other side with the appropriate hole (shown below).
- B. Use the same approach to combine Strap (R) with Pedal R (#20) (shown below).

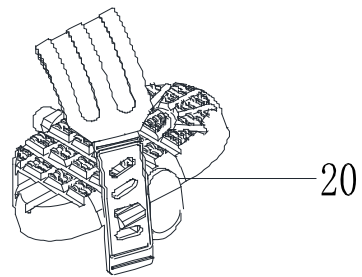
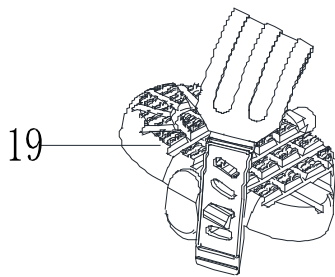
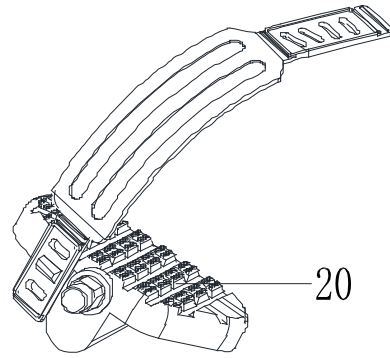
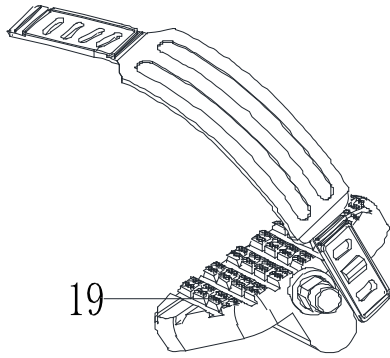
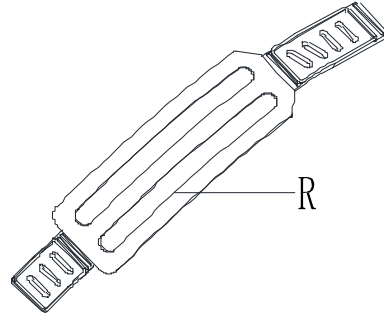
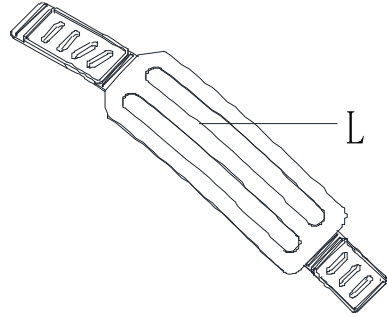

STEP 3

- A. Firmly thread the Left Pedal (#19) counterclockwise to the left crank.
- B. Firmly thread the Right Pedal (#20) clockwise to the right crank.

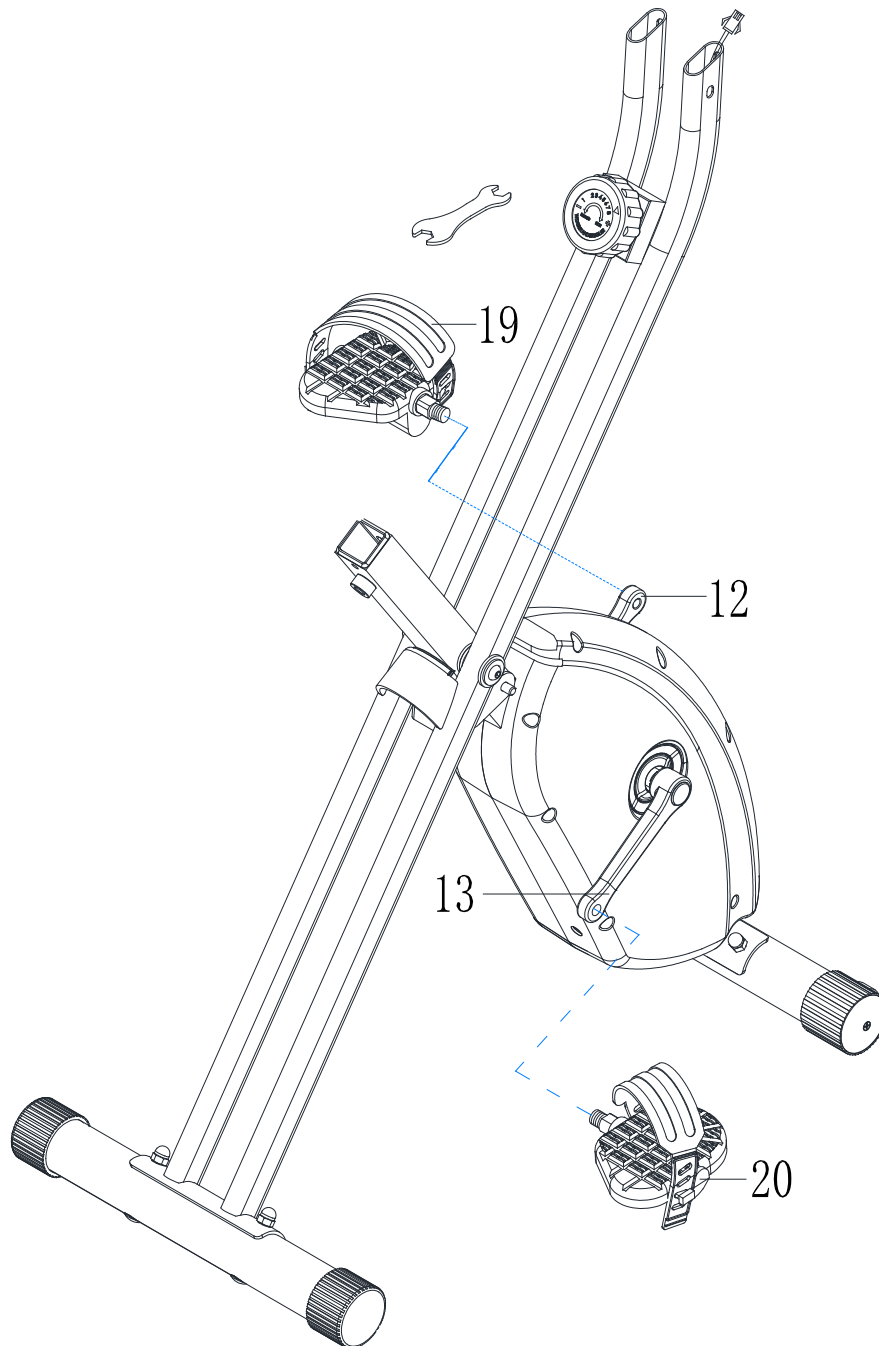

STEP 4

- A. Attach the Seat to the Seat Post (#3). Secure it with three Screws (#8).
- B. Insert the Seat Post into the opening on Main Frame, Use the Adjustment Knob (#10) to lock the seat height in position as desired.

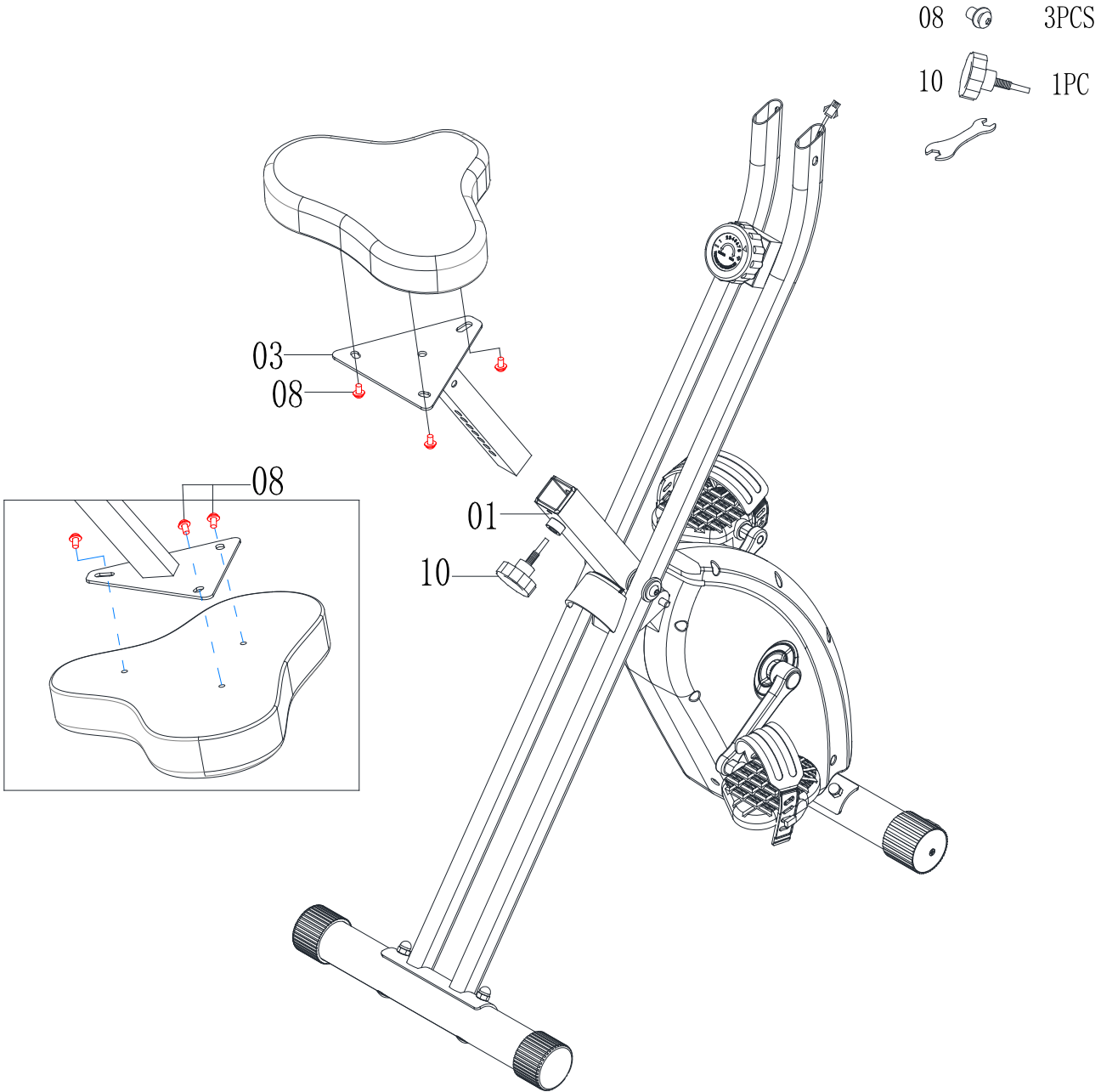

STEP 5

- A. Remove the Assembling bolt (#17) from the Handlebar (#4).
- B. Connect the computer wire (#11) to the computer (#9), attach the handlebar to the front post of the main frame. Secure it with Assembling Bolts (#17).

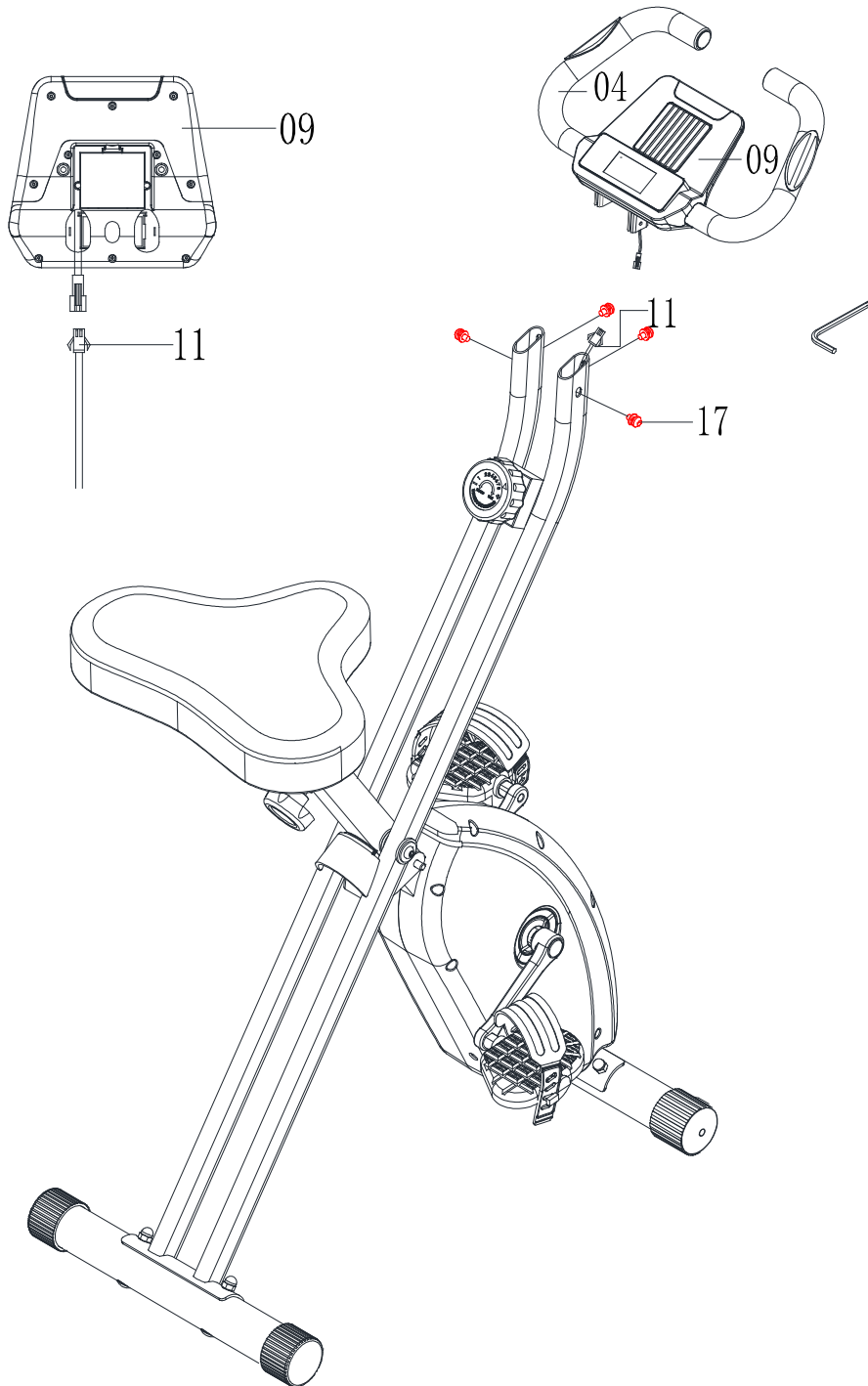

EXPLODED DIAGRAM

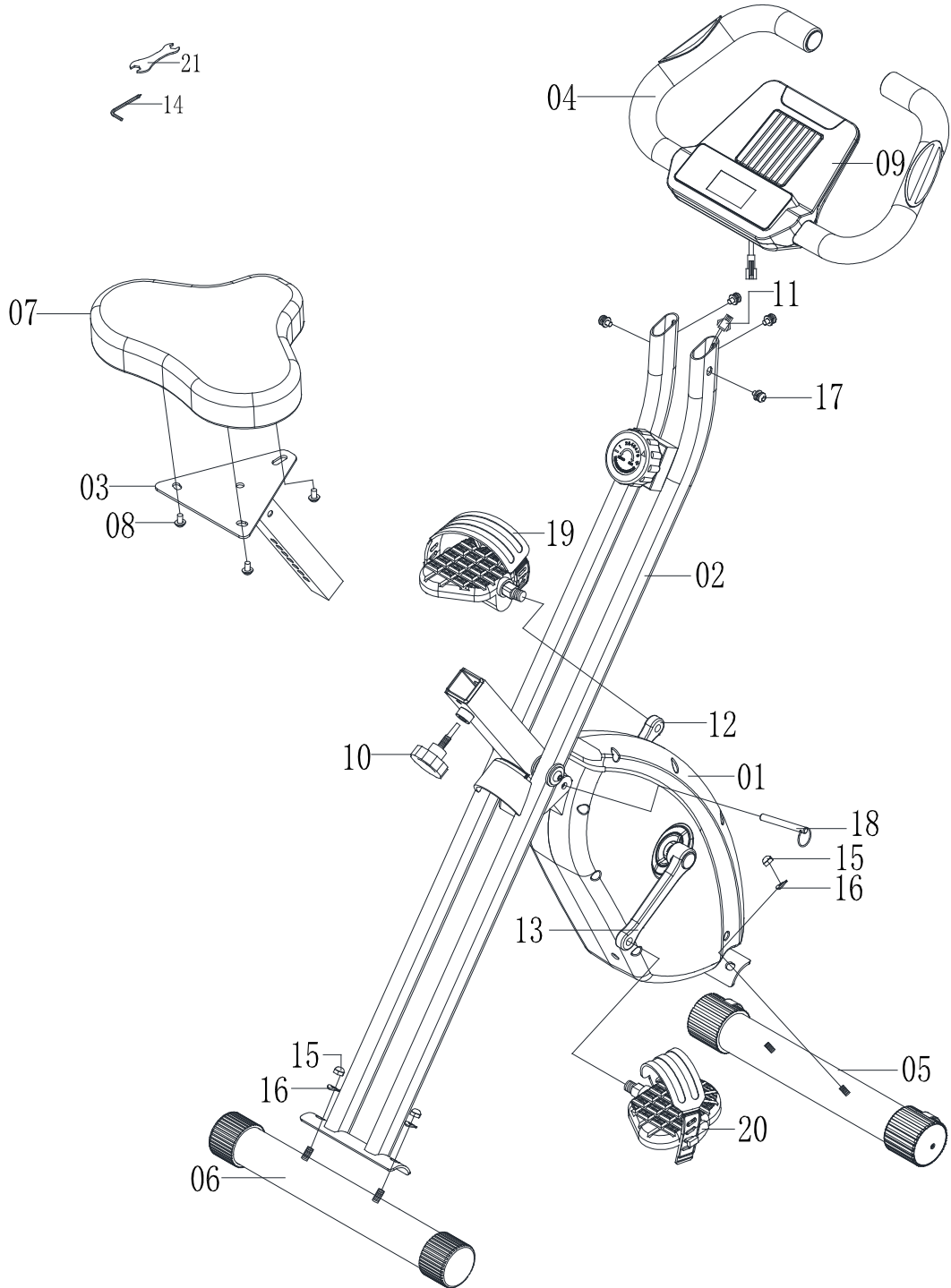

PARTS LIST

NO.	Description	Qty
1	Main Frame	1
2	Rear Support	1
3	Seat Post	1
4	Handlebar	1
5	Front stabilizer support	1
6	Rear Stabilizer support	1
7	Seat Pad	1
8	Screw for Seat Pad	3
9	Computer	1
10	Adjustment Knob	1
11	Computer wire	1
12	Crank (L)	1
13	Crank (R)	1
14	Allen Wrench	1
15	Domed Nut	4
16	Curved Washer	4
17	Assembling bolt	4
18	Safety-Pin	1
19	Pedal(L)	1
20	Pedal(R)	1
21	Crossing wrench	1

CARE, MAINTENANCE AND STORAGE

1. Inspect and tighten all parts each time you use the machine. Replace any worn parts immediately.
2. This machine can be cleaned using a damp cloth and mild non-abrasive detergent. Do not use solvents.
3. Store the rower IN-DOOR. Excess moisture and water would cause rust on the frame.
4. The rower shall be placed at least 24 inches away from the wall or/and any other object such as furniture to provide safe access to and passage around the machine.
5. To avoid possible injury, the help of two or more people are needed when moving the machine around.
6. Disposal Instructions – The equipment can be safely disassembled and disposed without unreasonable hazards. Call your local recycle agency regarding details of recycling.
7. **The maximum user weight is 300 lbs.**
8. **Assembled Dimension (L x W x H): 33.07” x 18.11” x 44.49”**
9. **Folded Dimension (L x W x H): 18.5” x 18.11” x 51.97”**

COMPUTER



FUNCTIONAL BUTTONS:

- MODE** - Push down to select functions.
- SET** - To set the time, distance, calories and pulse.
- RESET** - For resetting the time, distance, calories and pulse.

FUNCTION AND OPERATIONS:

- 1.SCAN:** Press “MODE” button until “SCAN” appears, monitor will cycle through all the 6 functions: time, speed, distance, calorie, odometer and pulse. Each function will be displayed for 6 seconds.
- 2.TIME:** (1) Count the total time from exercise start to end.
(2) Press “MODE” button until “TIME” appears, press “SET” button to set exercise time. Automatically count down from target value during exercise.
- 3.SPEED:** Display current speed.
- 4.DISTANCE:** (1) Count the distance from exercise start to end.
(2) Press “MODE” button until “DIST” appears. Press “SET” button to set exercise distance. Automatically count down from target value during exercise.
- 5.CALORIES:** (1) Count the total calories from exercise start to end.
(2) Press “MODE” button until “CAL” appears. Press “SET” button to set exercise calories. Automatically count down from target value during exercise.
- 6. ODOMETER:** Monitor will display the total accumulated distance.
- 7. PULSE:** Press MODE button until “PULSE” appears. Before measuring your pulse rate, please place both of your palms on both contact pads and the monitor will show your current heartbeat rate in beats per minute (BPM) on the LCD after 6~7 seconds.
Remark: During the process of measuring pulse, the measurement value may be higher than the virtual pulse rate during the first 2~3 seconds, then will return to normal level. The measurement value can not be regarded as the basis of medical treatment.

NOTE:

- 1. If the display is faint or shows no figures, please replace the batteries.
- 2. The monitor will automatically shut off if there is no signal received after 4 minutes.

SPECIFICATIONS:

FUNCTION	AUTO SCAN	Every 6 seconds
	TIME	0:00~99:59'
	CURRENT SPEED	0.0~999.9 MILE/H
	TRIP DISTANCE	0.00~999.9 MILE
	CALORIES	0.0~999.9 CAL
	ODOMETER	0.0 ~ 9999 MILE
	PULSE RATE	40~240 BPM
BATTERY TYPE		2pcs of SIZE –AAA
OPERATING TEMPERATURE		0°C ~ +40°C
STORAGE TEMPERATURE		-10°C ~ +60°C

EXERCISE GUIDELINES

Using your **AMZ-150BK** will provide you with several benefits, it will improve your physical fitness, tone muscle and in conjunction with calorie controlled diet help you lose weight.

1. The Warm Up Phase

This stage helps get the blood flowing around the body and the muscles working properly. It will also reduce the risk of cramp and muscle injury. It is advisable to do a few stretching exercises as shown below. Each stretch should be held for approximately 30 seconds, do not force or jerk your muscles into a stretch - if it hurts, STOP.

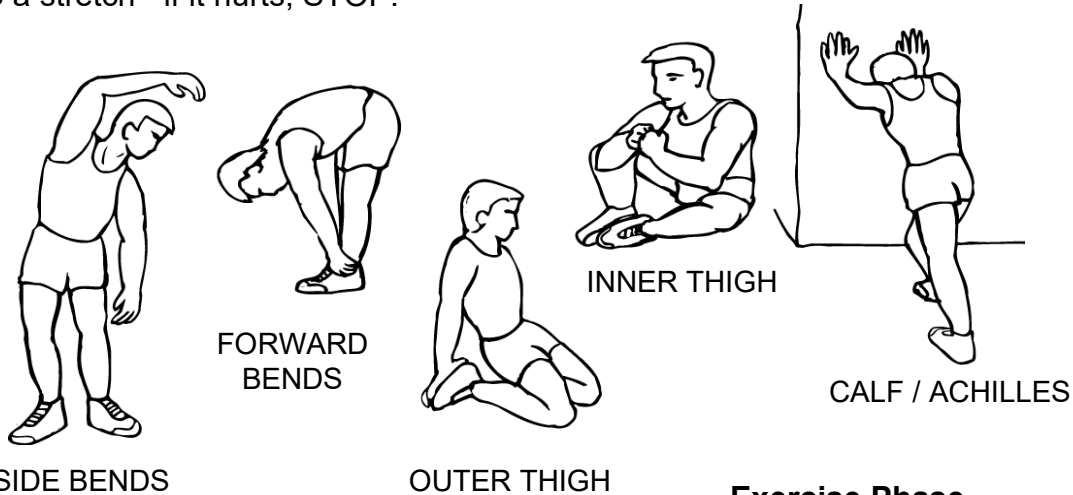

2. The

Exercise Phase

This is the stage where you put the effort in. After regular use, the muscles in your legs will become more flexible. Work to your targeted heart rate but it is very important to maintain a steady tempo throughout. The rate of work should be sufficient to raise your heartbeat into the target zone shown on the graph below.

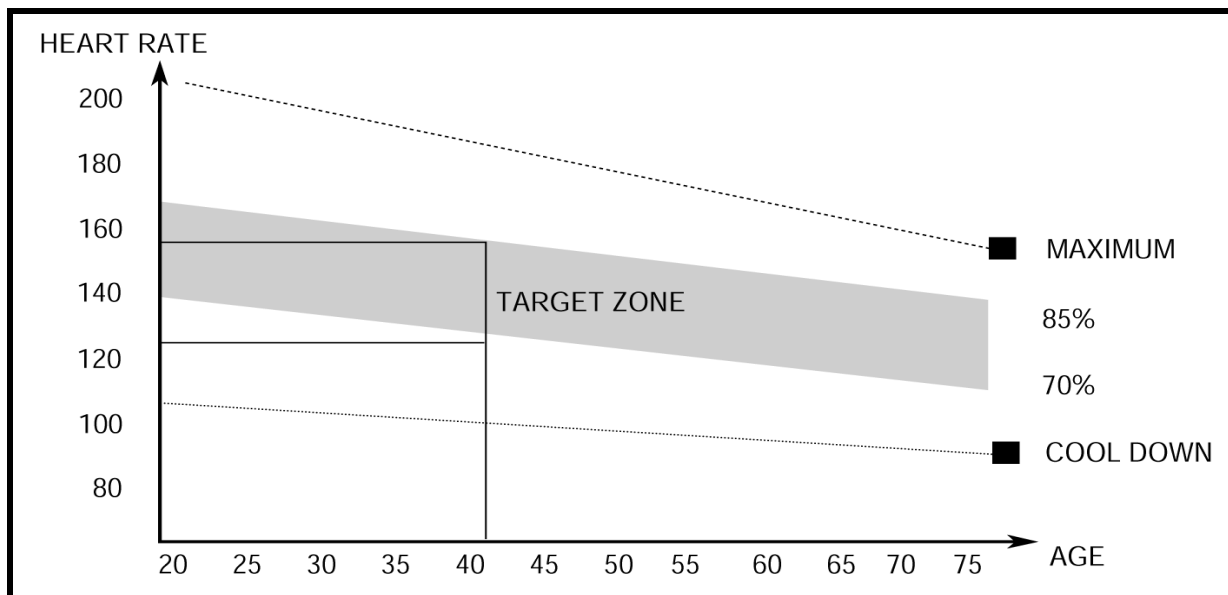

This stage should last for a minimum of 12 minutes though most people start at about 15-20 minutes

3. The Cool Down Phase

This stage is to let your Cardio-vascular System and muscles wind down. This is a repeat of the warm up exercise e.g. reduce your tempo, continue for approximately 5 minutes. The stretching exercises should now be repeated, again remembering not to force or jerk your muscles into the stretch.

As you get fitter you may need to train longer and harder. It is advisable to train at least three times a week, and if possible space your workouts evenly throughout the week.

MUSCLE TONING

To tone muscle while on your **MAGNETIC BIKE** you will need to have the resistance set quite high. This will put more strain on our leg muscles and may mean you cannot train for as long as you would like. If you are also trying to improve your fitness you need to alter your training program. You should train as normal during the warm up and cool down phases, but towards the end of the exercise phase you should increase resistance making your legs work harder. You will have to reduce your speed to keep your heart rate in the target zone.

WEIGHT LOSS

The important factor here is the amount of effort you put in. The harder and longer you work the more calories you will burn. Effectively this is the same as if you were training to improve your fitness, the difference is the goal.

IMPEX[®] INC.

LIMITED WARRANTY

IMPEX Inc. ("IMPEX[®]") warrants this product to be free from defects in workmanship and material, under normal use and service conditions, for a period of two years on the Frame from the date of purchase. This warranty extends only to the original purchaser. IMPEX's obligation under this Warranty is limited to replacing or repairing, at IMPEX's option.

All returns must be pre-authorized by IMPEX. Pre-authorization may be obtained by calling IMPEX Customer Service Department at 1-800-999-8899. All freights for products return to IMPEX must be prepaid by the customer. This warranty does not extend to any product or damage to a product caused by or attributable to freight damage, abuse, misuse, improper or abnormal usage or repairs not provided by an IMPEX authorized service center or for products used for commercial or rental purposes. No other warranty beyond that specifically set forth above is authorized by IMPEX.

IMPEX is not responsible or liable for indirect, special or consequential damages arising out of or in connection with the use or performance of the product or other damages with respect to any economic loss, loss of property, loss of revenues or profits, loss of enjoyments or use, costs of removal, installation or other consequential damages or whatsoever natures. Some states do not allow the exclusion or limitation of incidental or consequential damages. Accordingly, the above limitation may not apply to you.

The warranty extended hereunder is in lieu of any and all other warranties and any implied warranties of merchantability or fitness for a particular purpose is limited in its scope and duration to the terms set forth herein. Some states do not allow limitations on how long an implied warranty lasts. Accordingly, the above limitation may not apply to you.

This warranty gives you specific legal right. You may also have other rights which vary from state to state. Register on-line www.marcypro.com

IMPEX[®] INC.
2801 S. Towne Ave.
Pomona, CA 91766

ORDERING REPLACEMENT PARTS

Replacement parts can be ordered by calling our Customer Service Department toll-free at **1-800-999-8899** during our regular business hours: Monday through Friday, 9 am until 5 pm Pacific standard time.

support@impex-fitness.com

When ordering replacement part, always give the following information.

1. Model
2. Description of Parts
3. Part Number
4. Date of Purchase