

NOTE:
Please read all instructions
carefully before using this
product

Table of Contents

Safety Notice

Hardware Pack

Assembly Instruction

Parts List

Warranty

Ordering Parts

Model
AMZ-948BK

Retain This
Manual for
Reference

180912

ASSEMBLY &
OWNER'S
MANUAL

CIRCUIT FITNESS

CLUB REVOLUTION CYCLE AMZ-948BK

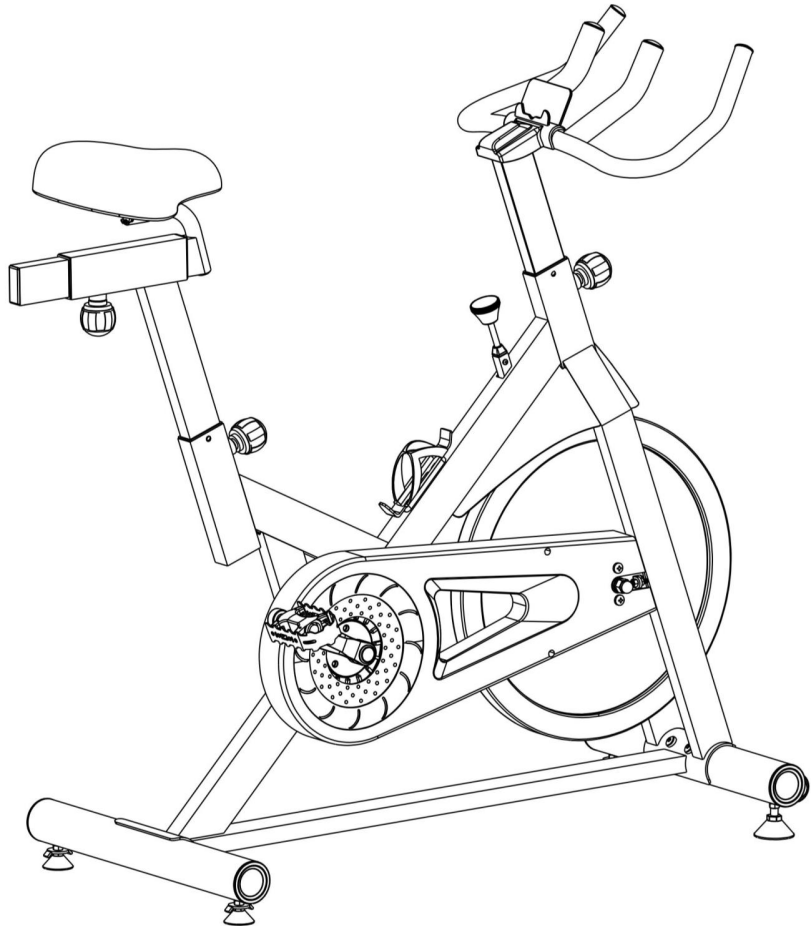

IMPEX® INC.

2801 S. Towne Ave., Pomona, CA 91766
Tel: (800) 999-8899 Fax: (626) 961-9966

www.marcypro.com

support@impex-fitness.com

TABLE OF CONTENTS

BEFORE YOU BEGIN	1
IMPORTANT SAFETY NOTICES	2
WARNING LABEL PLACEMENT	3
HARDWARE PACK	4
COMPONENT FOR ASSEMBLY	5
IMPORTANT ASSEMBLY INSTRUCTION	6
EXPLODED DIAGRAM	14
PARTS LIST	15
CARE AND MAINTENANCE, WEIGHT CAPACITY & DIMS.	16
EXERCISE GUIDELINES	17
WARRANTY	19
ORDERING PARTS	19

BEFORE YOU BEGIN

Thank you for selecting the CIRCUIT FITNESS Club Revolution Cycle by IMPEX[®] INC. For your safety and benefit, read this manual carefully before using the bike. As a manufacturer, we are committed to provide you complete customer satisfaction. If you have any questions, or find there are missing or damaged parts, we guarantee you complete satisfaction through direct assistance from our factory. To avoid unnecessary delays, *please call our TOLL-FREE customer service number.* Our Customer Service Agents will provide immediate assistance to you.

Toll-Free Customer Service Number

1-800-999-8899

Mon. - Fri. 9 a.m. - 5 p.m. PST

www.marcypro.com

support@impex-fitness.com

IMPORTANT SAFETY NOTICE

PRECAUTIONS

This exercise bike is built for optimum safety. However, certain precautions apply whenever you operate a piece of exercise equipment. Be sure to read the entire manual before you assemble or operate your bike. In particular, note the following safety precautions:

1. **Keep children and pets away from the exercise bike at all times. DO NOT leave children unattended in the same room with the bike.**
2. Only one person at a time should use the bike.
3. If the user experiences dizziness, nausea, chest pain, or any other abnormal symptoms, STOP the workout at once. CONSULT A PHYSICIAN IMMEDIATELY.
4. Position the bike on a clear, leveled surface. DO NOT use the bike near water or outdoors.
5. Keep hands away from all moving parts.
6. Always wear appropriate workout clothing when exercising. DO NOT wear robes or other clothing that could become caught in the bike. Running or aerobic shoes are also required when using the bike.
7. Use the bike only for its intended use as described in this manual. DO NOT use attachments not recommended by the manufacturer.
8. Do not place any sharp object around the bike.
9. Disabled person should not use the bike without a qualified person or physician in attendance.
10. Before using the bike to exercise, always do stretching exercises to properly warm up.
11. Never operate the bike if it is not functioning properly.
12. Read all warnings posted on the exercise bike.
13. Inspect the exercise bike for worn or loose component prior to use. Tighten/replace any loose or wore components prior to use.
14. Care should be taken in mounting or dismounting the exercise bike.
15. **This exercise bike is for consumer and home use only.**





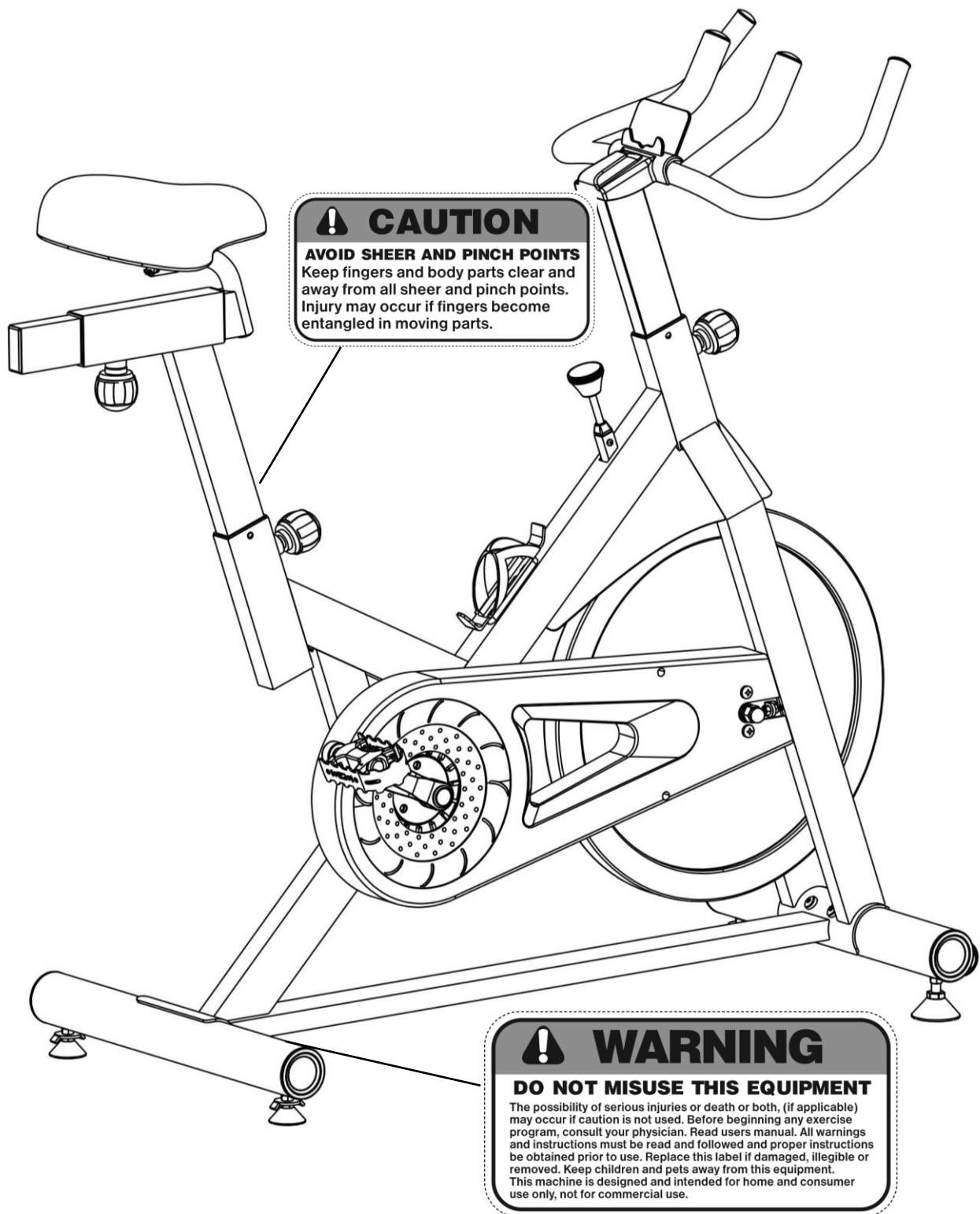

WARNING: BEFORE BEGINNING ANY EXERCISE PROGRAM, CONSULT YOUR PHYSICIAN. THIS IS ESPECIALLY IMPORTANT FOR INDIVIDUALS OVER THE AGE OF 35 OR PERSONS WITH PRE-EXISTING HEALTH PROBLEMS. READ ALL INSTRUCTIONS BEFORE USING ANY FITNESS EQUIPMENT. IMPEX INC. ASSUMES NO RESPONSIBILITY FOR PERSONAL INJURY OR PROPERTY DAMAGE SUSTAINED BY OR THROUGH THE USE OF THIS PRODUCT. SAVE THESE INSTRUCTIONS.

WARNING LABEL PLACEMENT

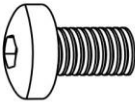

The Warning Labels and Caution Label shown here have been placed on the Rear Stabilizer and Main Frame. If the labels are missing or illegible, please call customer service at 1-800-999-8899 for replacement. Apply the labels in location shown.

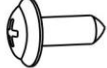
HARDWARE PACK

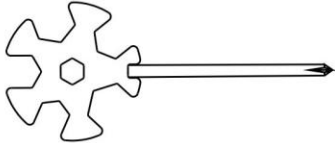
<p>36</p>  <p>M10 x 1/3" Allen Bolt x 6</p>	<p>37</p>  <p>Lock Washer x 6</p>	<p>38</p>  <p>Flat Washer x 2</p>
<p>39</p>  <p>Curved Washer x 4</p>	<p>42</p>  <p>ST4.2 x 2/3" Self-Tapping Screw x 3</p>	
 <p>6# Allen Key</p>	 <p>Multi-Wrench</p>	

COMPONENTS FOR ASSEMBLY

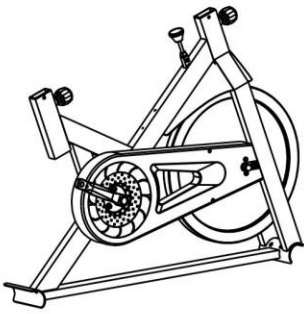

No. 1 Main Body

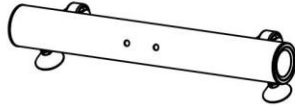

No. 2 Front Stabilizer

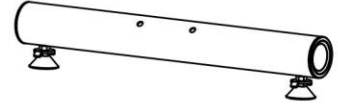

No. 3 Rear Stabilizer

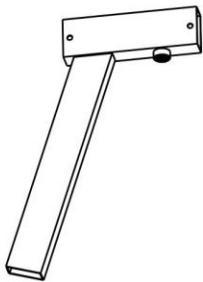

No.4 Seat Support Frame

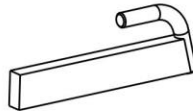

No. 5 Seat Support



No. 6 Handle Bar Support Frame

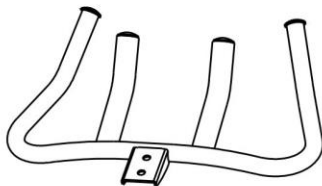

No. 7 Handle Bar

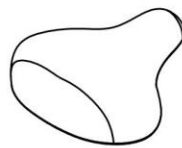

No. 9 Seat Pad



No. 8 Lock Knob



No. 16 Water Bottle Holder



NO. 20 Accessory Rack

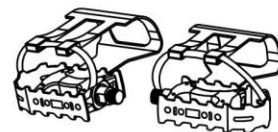

NO. 31 Pedals

ASSEMBLY INSTRUCTION

- **Tools Required For Assembling the Bike: One Crossing Wrench and Allen Wrench, provided by manufacturer.**
- **NOTE: It is strongly recommended that two or more people assemble this bike to avoid possible injury.**

STEP 1

- A.) Attach the Front Stabilizer (#2) and Rear Stabilizer (#3) to the Main Frame (#1). Secure it with two M10 x $\frac{1}{3}$ " Allen Bolts (#36), two $\text{\O} \frac{2}{3}$ " Lock Washers (#37), and two $\text{\O} \frac{2}{3}$ " Curved Washers (#39).

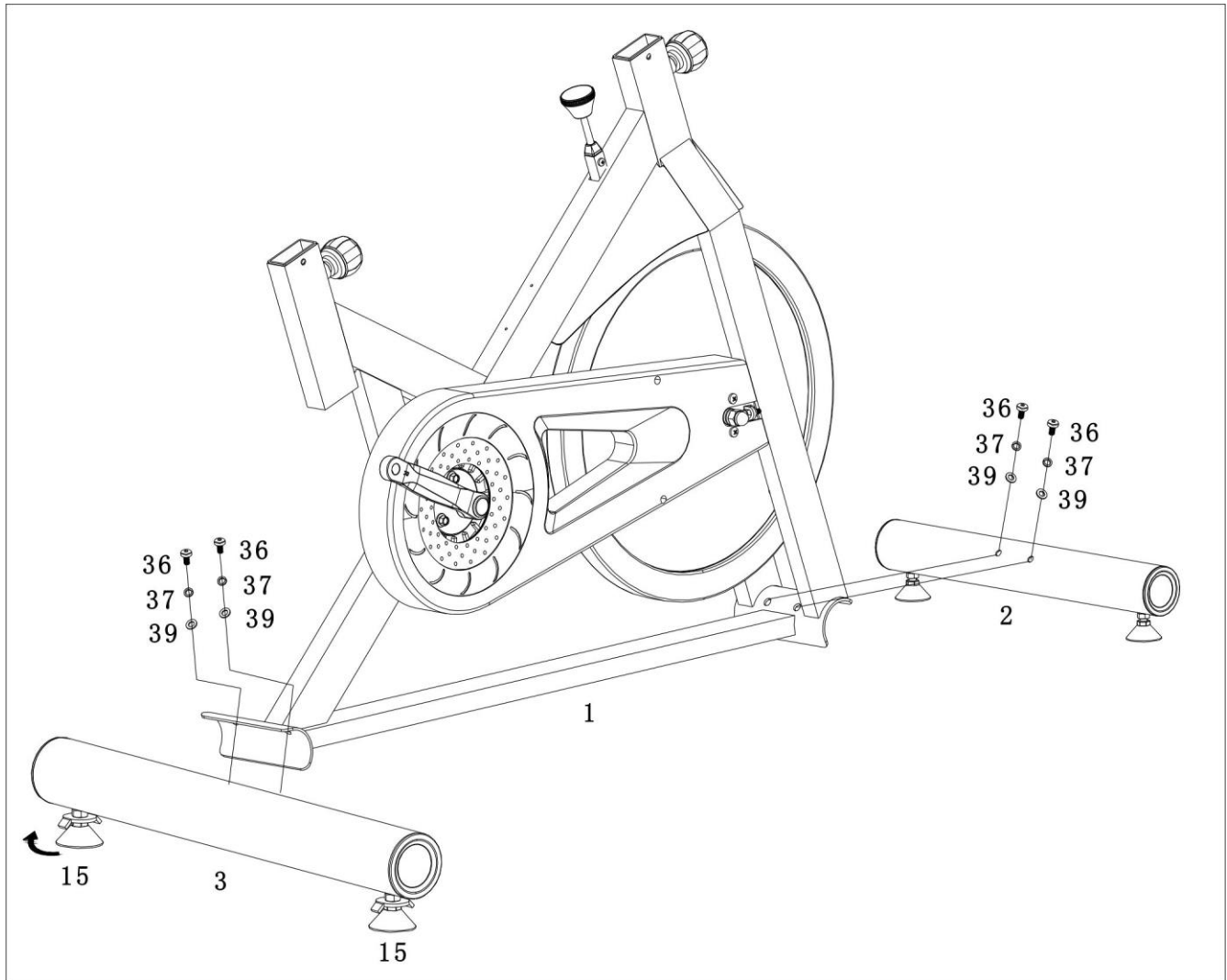

Note: the Stabilizers can be adjusted (by twisting the leveler adjustor #15) to ensure the bike is stable.

STEP 2

- A.) Install the Locking knob into Seat Support Frame (#4) by threading in the locking knob (#8).
- B.) Insert the Seat Support Frame into the Main Frame and install a Locking knob into the Main Frame to secure the Seat Support Frame at the desired height.

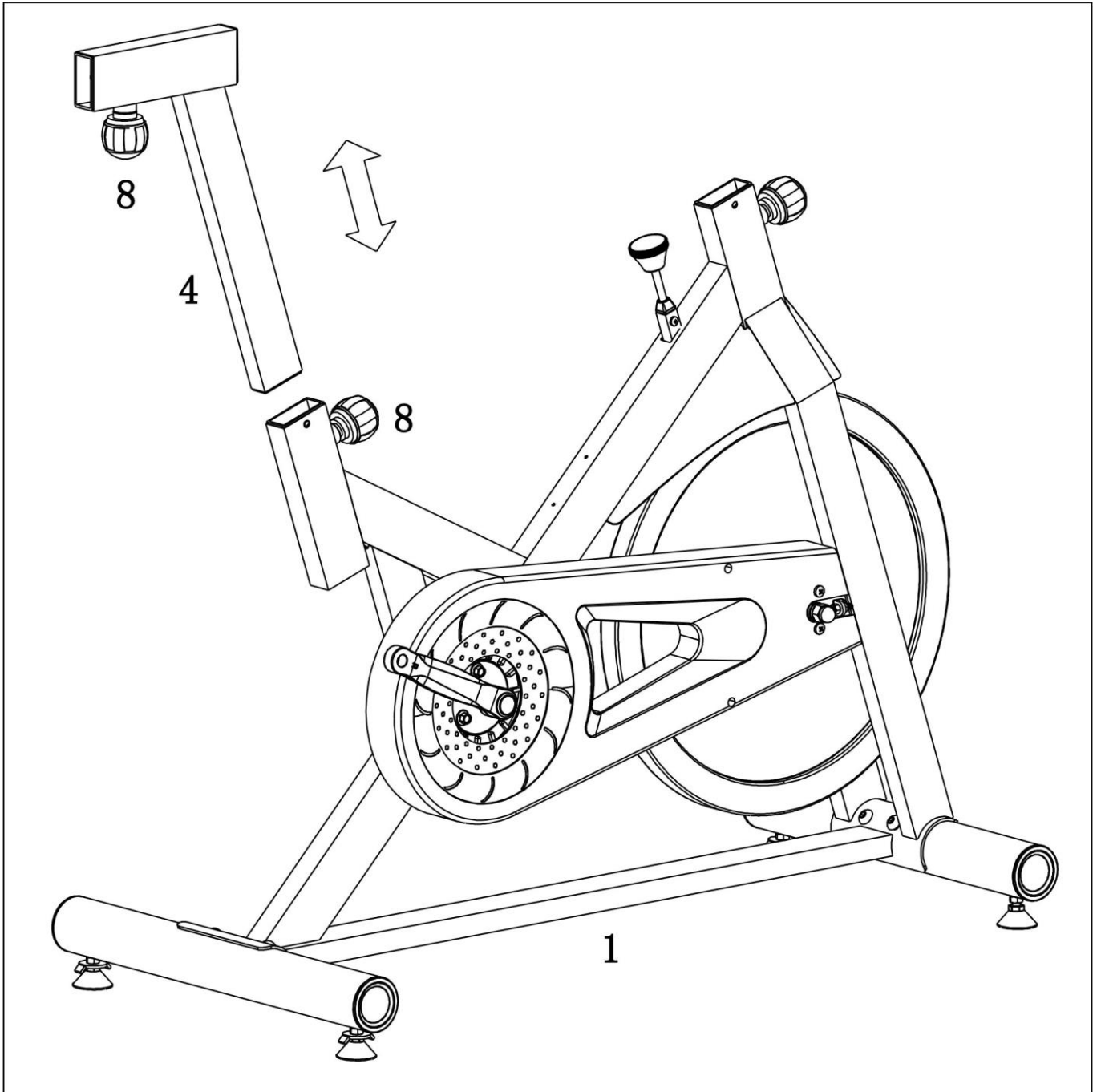

STEP 3

- A.) Insert the Seat Support (#5) into the Seat Adjustable Support and lock in with Locking Knob at the desired position.
- B.) Screw in the Pan Head Philips Self-Tapping Screw w/ Adhesive (#42) into the end of the Seat Support to prevent the Seat Support from accidentally slipping out.

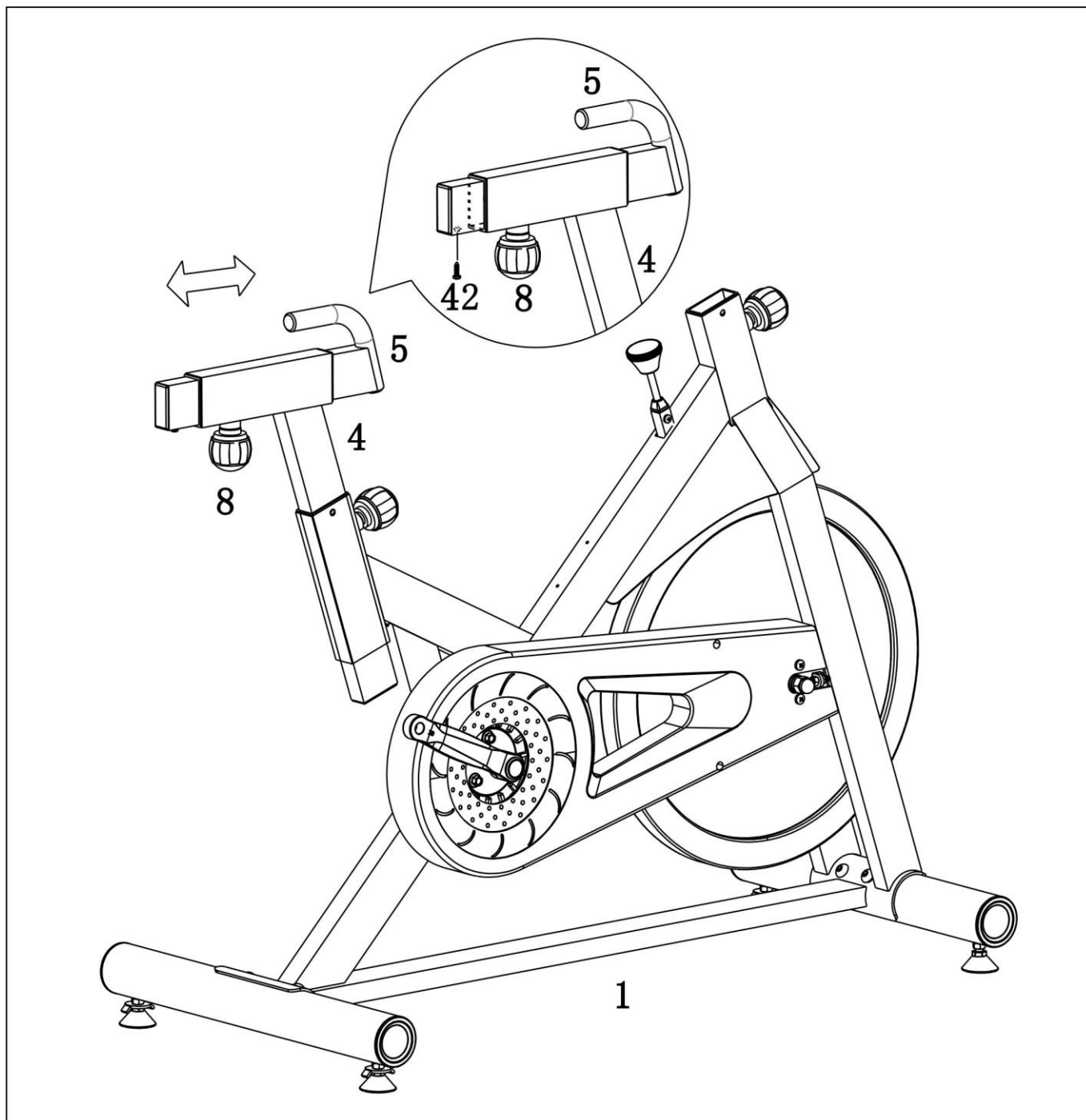

STEP 4

- A.) Install the Seat Pad (#9) onto the Seat Support.
- B.) Tighten the hex nuts with the provided Multi-Wrench.

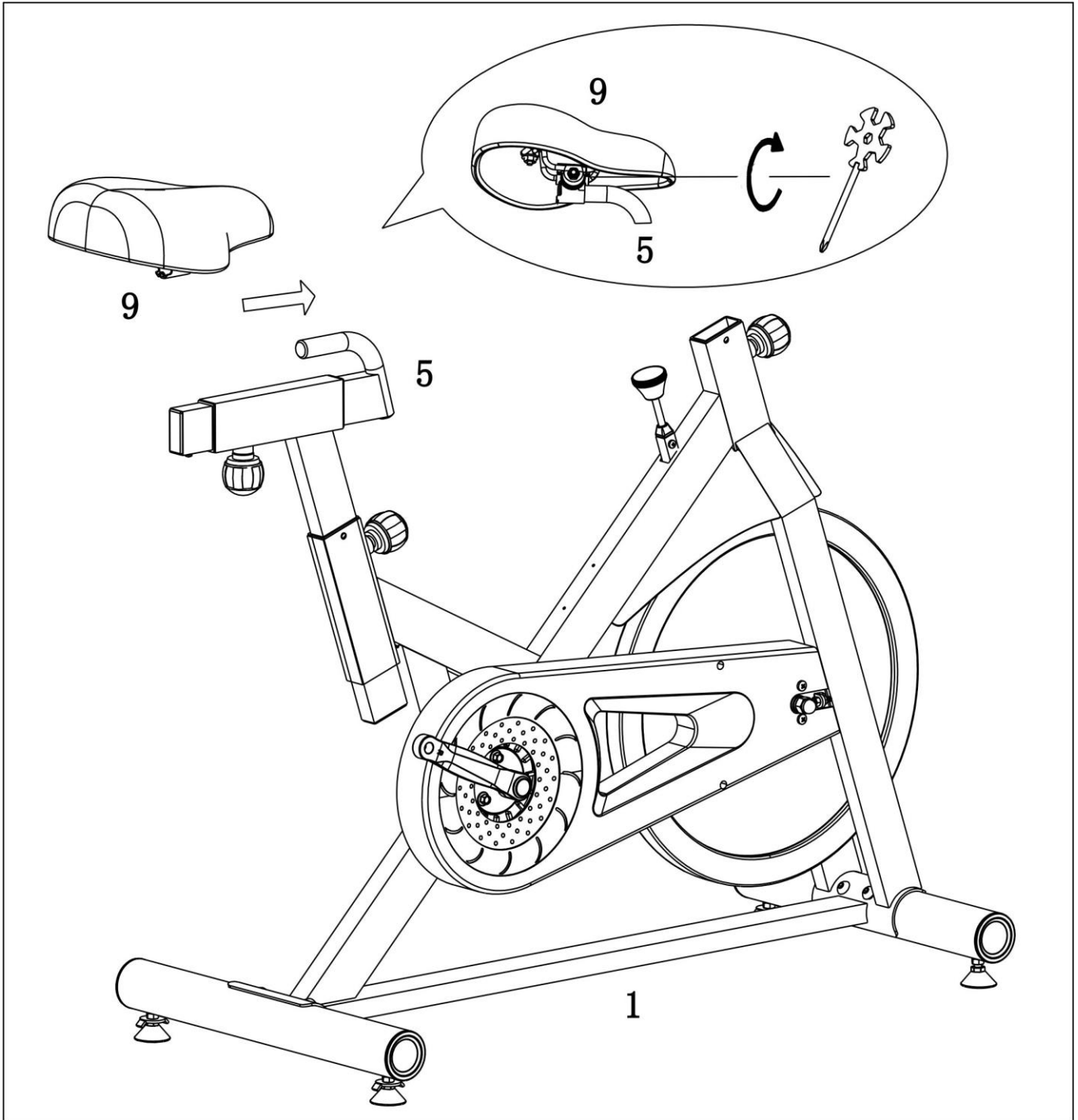

STEP 5

A.) Insert the Handle Bar Support Frame (#6) into the Main Frame. Install a Locking Knob (#8) and lock the Handle Bar Support Frame into a desired height.

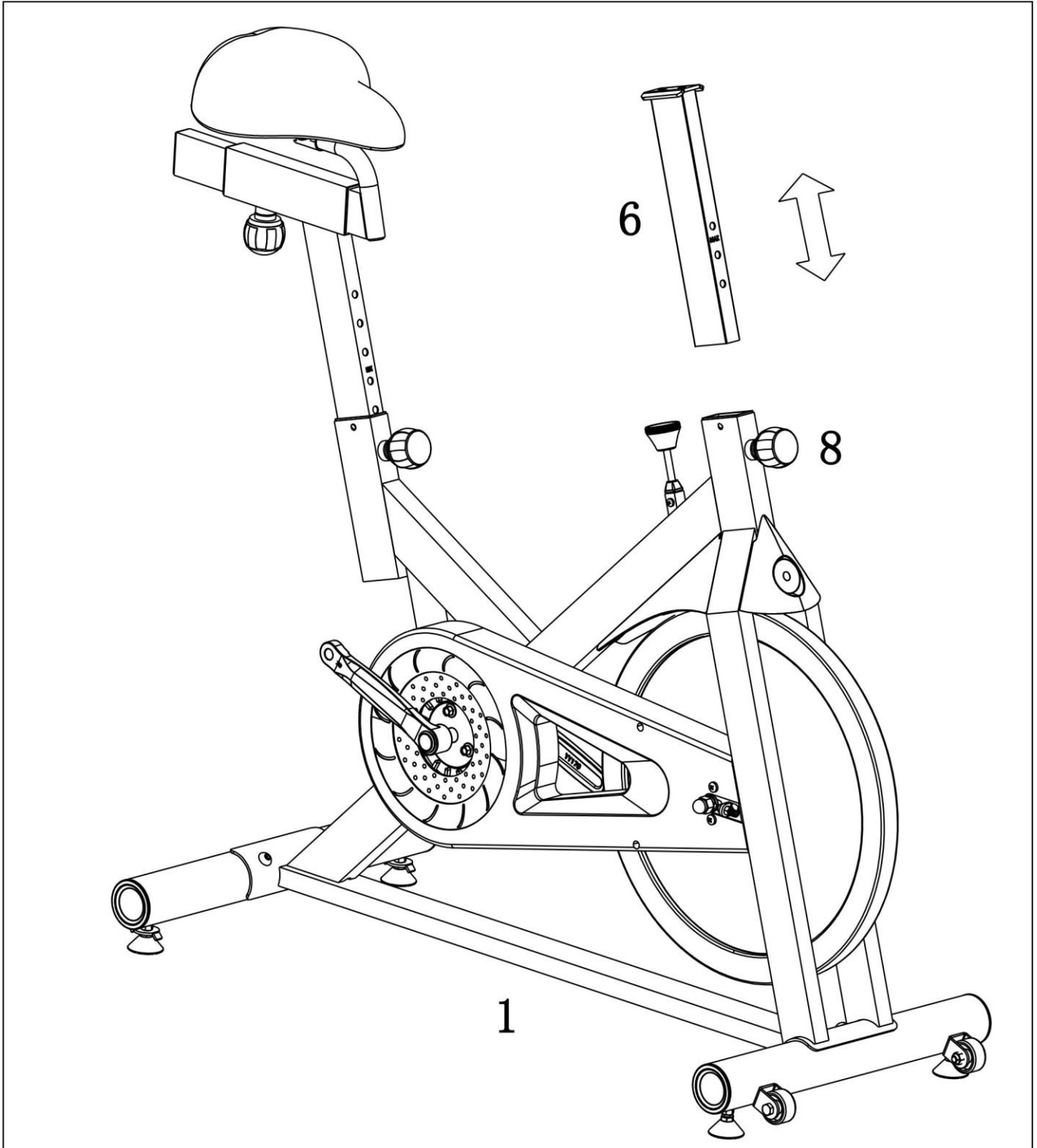

STEP 6

A.) Install the Handle Bar (#7) onto the Handle Bar Support Frame and secure with two Allen Bolts M10 x 1/3" (#36), two Locking Washers (#37) and two Flat Washers (#38).

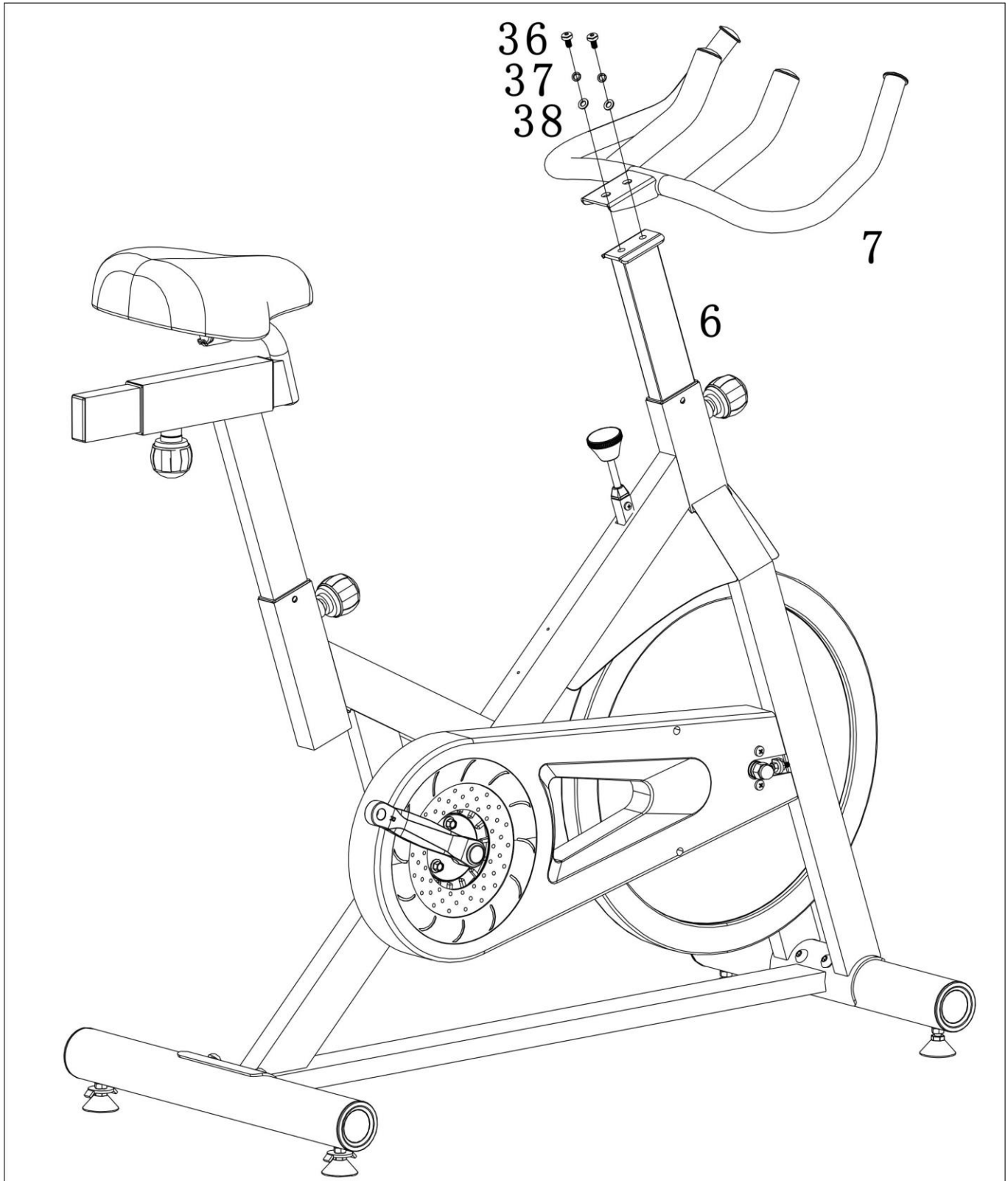

STEP 7

- A.) Install the Water Bottle Holder (#16) onto the Main Frame using two Pan Head Philips Self-Tapping Screw (#42).
- B.) Install the Accessory Rack (#20) by snapping the assembly onto the Handle Bar.

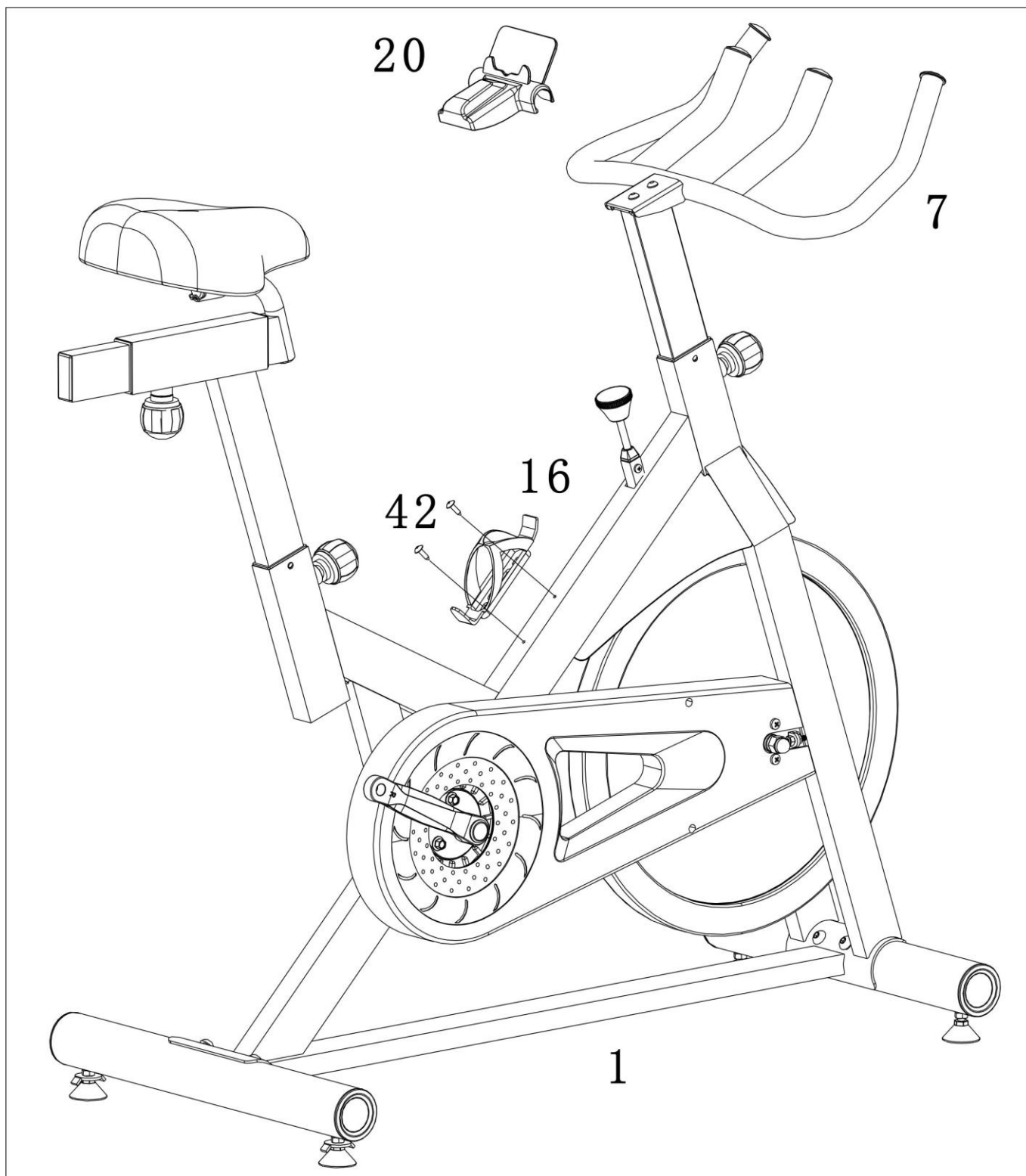

STEP 8

A.) Install the pedals in the below fashion:

- a. Part #31L will be threaded onto Part #30L in a COUNTER-CLOCK direction.
- b. Part #31R will be threaded onto Part #30R in a CLOCKWISE direction.

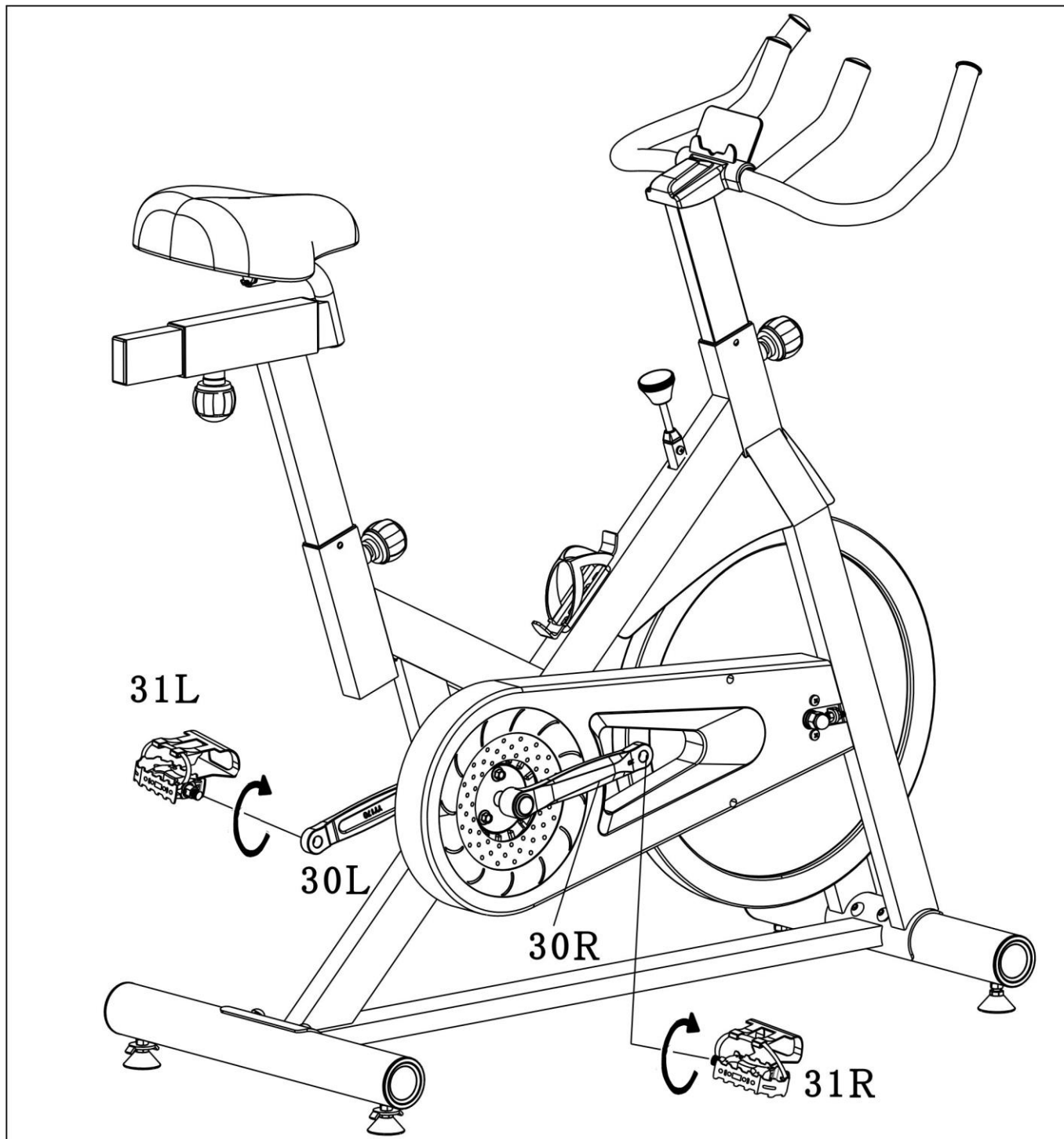

EXPLODED DIAGRAM

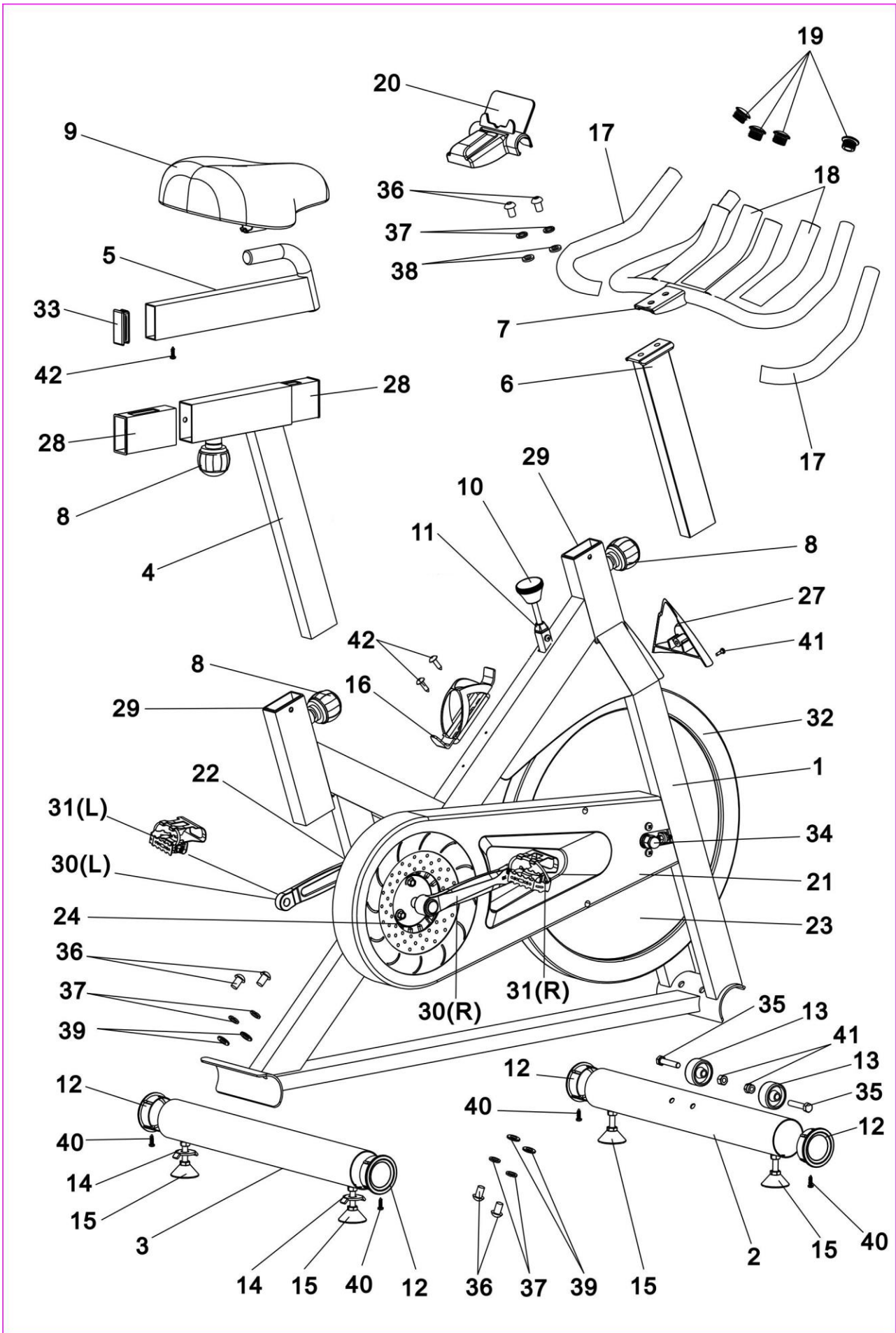

AMZ-948BK PARTS LIST

PART NO.	DESCRIPTION	SPEC.	QUANTITY
1	Main Frame		1
2	Front Stabilizer		1
3	Rear Stabilizer		1
4	Seat Support Frame		1
5	Seat Support		1
6	Handle Bar Support		1
7	Handle Bar		1
8	Locking Knob		3
9	Seat Pad		1
10	Brake Assembly		1
11	Brake Sleeve		1
12	Stabilizer End Cap		4
13	Transport Wheel		2
14	Leveler Lock		2
15	Leveler	M8	4
16	Water Bottle Holder		1
17	Grip (Long)		2
18	Grip (Short)		2
19	Handle Bar End Cap		4
20	Accessory Rack		1
21	Belt Cover		1
22	Belt Cover Housing		1
23	Flywheel Cover		2
24	Belt Cover Decorative Plate		1
25	Left Fork Guard		1
26	Right Fork Guard		1
27	Front Fork Guard		1
28	Seat Support Frame Sleeve		2
29	Handle Bar Support Frame Sleeve		2
30	Cranks		1 set (LR)
31	Pedals		1 set (LR)
32	Flywheel	30-lbs.	4
33	Seat Support End Cap		2
34	Flywheel Axle		1
35	Hex Bolt	M8 x 1½"	2
36	Allen Bolt	M10 x ⅓"	6
37	Locking Washer	Ø⅔	6
38	Flat Washer	Ø⅔	2
39	Curved Washer	Ø⅔	4
40	Pan Head Philips Self-Tapping Screw		4
41	Pan Head Philips Self-Tapping Screw w/ Adhesive	ST4.2x ⅔"	1
42	Padded Pan Head Philips Self-Tapping Screw w/ Adhesive	ST4.2x ⅔"	3
43	Aircraft Nut		2

CARE, MAINTENANCE AND STORAGE

1. Inspect and tighten all parts each time you use the bike. Replace any worn parts immediately.
2. The bike can be cleaned using a damp cloth and mild non-abrasive detergent. Do not use solvents.
3. Store the bike IN-DOOR. Excess moisture and water would cause rust on the frame.
4. The Bike shall be placed at least 24 inches away from the wall or/and any other object such as furniture to provide safe access to and passage around the bike.
5. To avoid possible injury, the help of two or more people are needed when moving the bike around.
6. Disposal Instructions – The equipment can be safely disassembled and disposed without unreasonable hazards. Call your local recycle agency regarding details of recycling.
7. **The maximum user weight is 300 lbs.**
8. **Assembled Dimension: 41"x20"x42"**

OPERATING NOTES

ADJUSTMENT

1. Use the Tension/Brake Knob (#10) to adjust the resistance for exercises.
2. The seat height adjustment is in approximately 1.5" increment.
*The seat height can be adjusted for multiple heights; ranging from 37.5" to 43".
3. Loosen and pull out the Lock Knob (#8). Slide the Seat Support Frame/ Handle Bar support to the desired height and lock at the position by fastening the Lock Knob
4. Loosen and pull out the seat Lock Knob (#8). Slide the Seat Support to the desired position and lock at the position by fastening the seat Lock Knob.

Stopping the Exercise

1. **Press down the Tension/Brake Knob (#10) to stop the fly wheel. ONLY when the flywheel has stopped, will it be safe to remove feet from pedals.**
2. **DO NOT stop pedaling: doing so could result in serious injury.**
3. **DO NOT attempt to stop the Fly Wheel by hands, feet or any other device not indicated in this instruction.**

TRANSPORT

The Bike has a pair Roller Wheels on Front Stabilizer.
To move, carefully tilt the cycle forward, and then roll.

EXERCISE GUIDELINES

Using your **Bike** will provide you with several benefits, it will improve your physical fitness, tone muscle and in conjunction with calorie controlled diet help you lose weight.

1. The Warm Up Phase

This stage helps get the blood flowing around the body and the muscles working properly. It will also reduce the risk of cramp and muscle injury. It is advisable to do a few stretching exercises as shown below. Each stretch should be held for approximately 30 seconds, do not force or jerk your muscles into a stretch - if it hurts, STOP.

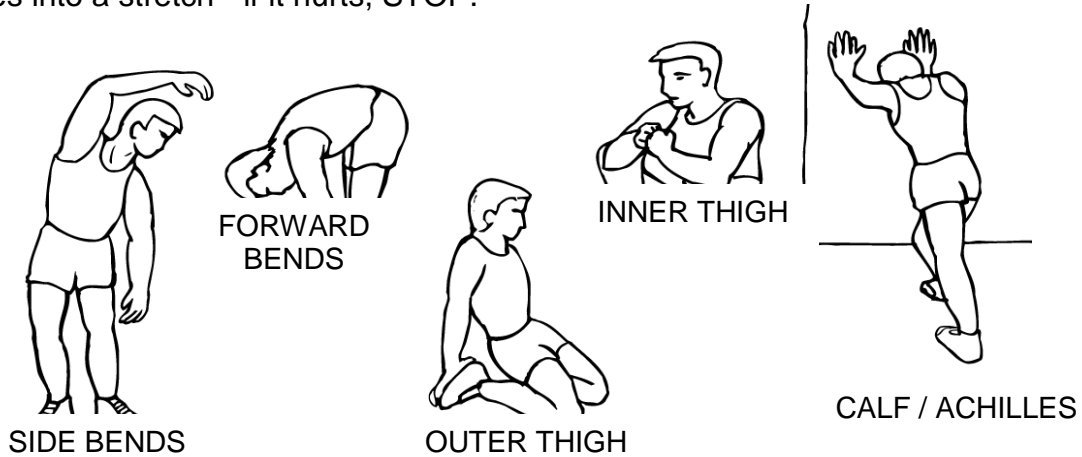

2. The Exercise Phase

This is the stage where you put the effort in. After regular use, the muscles in your legs will become more flexible. Work to your targeted heart rate but it is very important to maintain a steady tempo throughout. The rate of work should be sufficient to raise your heartbeat into the target zone shown on the graph below.

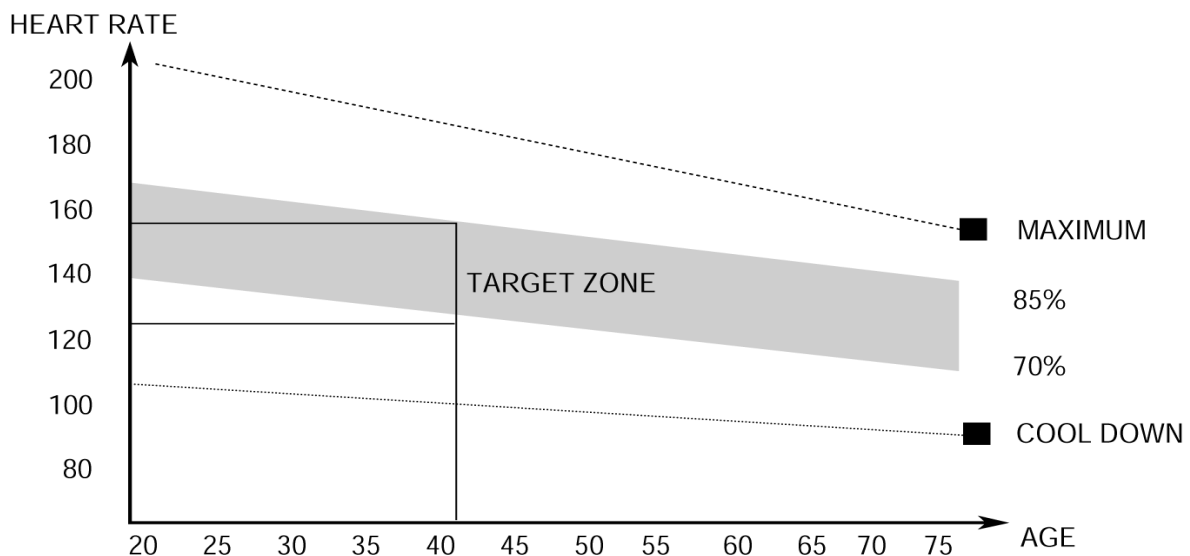

This stage should last for a minimum of 12 minutes though most people start at about 15-20 minutes

3. The Cool Down Phase

This stage is to let your Cardio-vascular System and muscles wind down. This is a repeat of the warm up exercise e.g. reduce your tempo, continue for approximately 5 minutes. The stretching exercises should now be repeated, again remembering not to force or jerk your muscles into the stretch.

As you get fitter you may need to train longer and harder. It is advisable to train at least three times a week, and if possible space your workouts evenly throughout the week.

MUSCLE TONING

To tone muscle while on your **bike** you will need to have the resistance set quite high. This will put more strain on our leg muscles and may mean you cannot train for as long as you would like. If you are also trying to improve your fitness you need to alter your training program. You should train as normal during the warm up and cool down phases, but towards the end of the exercise phase you should increase resistance making your legs work harder. You will have to reduce your speed to keep your heart rate in the target zone.

WEIGHT LOSS

The important factor here is the amount of effort you put in. The harder and longer you work the more calories you will burn. Effectively this is the same as if you were training to improve your fitness, the difference is the goal.

IMPEX[®] INC.

LIMITED WARRANTY

IMPEX Inc. ("IMPEX[®]") warrants this product to be free from defects in workmanship and material, under normal use and service conditions, for a period of two years on the Frame from the date of purchase. This warranty extends only to the original purchaser. IMPEX's obligation under this Warranty is limited to replacing or repairing, at IMPEX's option.

All returns must be pre-authorized by IMPEX. Pre-authorization may be obtained by calling IMPEX Customer Service Department at 1-800-999-8899. All freights for products return to IMPEX must be prepaid by the customer. This warranty does not extend to any product or damage to a product caused by or attributable to freight damage, abuse, misuse, improper or abnormal usage or repairs not provided by an IMPEX authorized service center or for products used for commercial or rental purposes. No other warranty beyond that specifically set forth above is authorized by IMPEX.

IMPEX is not responsible or liable for indirect, special or consequential damages arising out of or in connection with the use or performance of the product or other damages with respect to any economic loss, loss of property, loss of revenues or profits, loss of enjoyments or use, costs of removal, installation or other consequential damages or whatsoever natures. Some states do not allow the exclusion or limitation of incidental or consequential damages. Accordingly, the above limitation may not apply to you.

The warranty extended hereunder is in lieu of any and all other warranties and any implied warranties of merchantability or fitness for a particular purpose is limited in its scope and duration to the terms set forth herein. Some states do not allow limitations on how long an implied warranty lasts. Accordingly, the above limitation may not apply to you.

This warranty gives you specific legal right. You may also have other rights which vary from state to state.

Register on-line www.marcypro.com

IMPEX[®] INC.
2801 S, Towne Ave.
Pomona, CA 91766

ORDERING REPLACEMENT PARTS

Replacement parts can be ordered by calling our Customer Service Department toll-free at **1-800-999-8899** during our regular business hours: Monday through Friday, 9 am until 5 pm Pacific standard time.

support@impex-fitness.com

When ordering replacement part, always give the following information.

1. Model
2. Description of Parts
3. Part Number
4. Date of Purchase