

NOTE:
Please read all instructions
carefully before using this
product

Table of Contents

Safety Notice

Hardware Identifier

Assembly Instruction

Parts List

Resistance Chart

Warranty

Ordering Parts

Model
MWM CR5N

Retain This
Manual for
Reference

07-24-03

OWNER'S
MANUAL

IMPEx
FITNESS PRODUCTS

MARCY CORNER GYM CR 5N

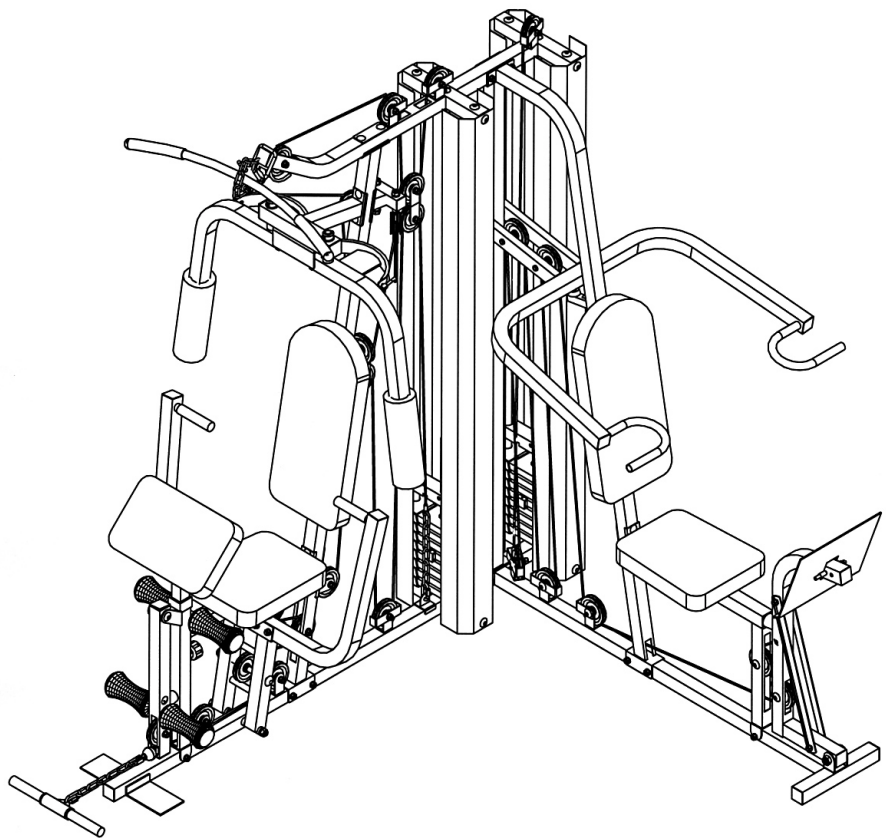

IMPEX FITNESS PRODUCTS

14777 DON JULIAN RD., CITY OF INDUSTRY, CA 91746

Tel: (800) 999-8899 Fax: (626) 961-9966

www.impex-fitness.com

info@impex-fitness.com

TABLE OF CONTENTS

BEFORE YOU BEGIN.....	1
IMPORTANT SAFETY NOTICES.....	2
HARDWARE IDENTIFIER.....	3
ASSEMBLY INSTRUCTIONS.....	4
PARTS LIST.....	23
RESISTANCE CHART.....	24
WARRANTY.....	25
ORDERING PARTS.....	25

BEFORE YOU BEGIN

Thank you for selecting the MARCY CR5N CORNER GYM by IMPEX FITNESS PRODUCTS. For your safety and benefit, read this manual carefully before using the machine. As a manufacturer, we are committed to provide you complete customer satisfaction. If you have any questions, or find there are missing or damaged parts, we guarantee you complete satisfaction through direct assistance from our factory. To avoid unnecessary delays, *please call our TOLL-FREE customer service number.* Our Customer Service Agents will provide immediate assistance to you.

Toll-Free Customer Service Number

1-800-999-8899

Mon. – Fri. 9 a.m. – 5 p.m. PST

www.impex-fitness.com

info@impex-fitness.com

IMPORTANT SAFETY NOTICE

PRECAUTIONS

This exercise machine is built for optimum safety. However, certain precautions apply whenever you operate a piece of exercise equipment. Be sure to read the entire manual before you assemble or operate your machine. In particular, note the following safety precautions:

1. **Keep children and pets away from the machine at all times. DO NOT leave children unattended in the same room with the machine.**
2. Only one person at a time should use the machine.
3. If the user experiences dizziness, nausea, chest pain, or any other abnormal symptoms, STOP the workout at once. CONSULT A PHYSICIAN IMMEDIATELY.
4. Position the machine on a clear, leveled surface. DO NOT use the machine near water or outdoors.
5. Keep hands away from all moving parts.
6. Always wear appropriate workout clothing when exercising. DO NOT wear robes or other clothing that could become caught in the machine. Running or aerobic shoes are also required when using the machine.
7. Use the machine only for its intended use as described in this manual. DO NOT use attachments not recommended by the manufacturer.
8. Do not place any sharp object around the machine.
9. Disabled person should not use the machine without a qualified person or physician in attendance.
10. Before using the machine to exercise, always do stretching exercises to properly warm up.
11. Never operate the machine if the machine is not functioning properly.

WARNING: BEFORE BEGINNING ANY EXERCISE PROGRAM, CONSULT YOUR PHYSICIAN. THIS IS ESPECIALLY IMPORTANT FOR INDIVIDUALS OVER THE AGE OF 35 OR PERSONS WITH PRE-EXISTING HEALTH PROBLEMS. READ ALL INSTRUCTIONS BEFORE USING ANY FITNESS EQUIPMENT. IMPEX INC. ASSUMES NO RESPONSIBILITY FOR PERSONAL INJURY OR PROPERTY DAMAGE SUSTAINED BY OR THROUGH THE USE OF THIS PRODUCT.

SAVE THESE INSTRUCTIONS.

HARDWARE IDENTIFIER

PLACE WASHER, END OF BOLT, OR SCREW ON CIRCLE TO CHECK FOR CORRECT SIZE.

MILLIMETERS

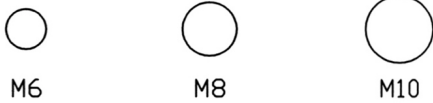

INCHES

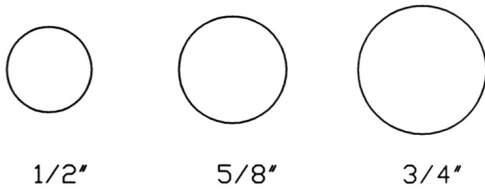

REPLACEMENT PARTS

Thank you for purchasing IMPEX Product. Although we go to great effort to ensure the quality of our products, occasionally errors or omissions occur. Should you find either a defective or missing part in this product, please contact us for a replacement at the telephone number.

QUESTION ?



1-800-999-8899

NOTE: When installing a Aircraft Nut (also called Nylon or Lock Nut), Please use two adjustable wrenches to tighten down the Nut. Hold down the Bolt with one wrench, and use the other wrench to turn the Nut clockwise.

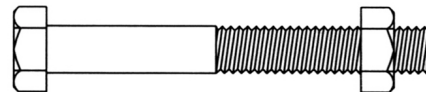
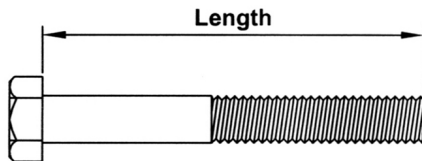

HEX HEAD BOLT

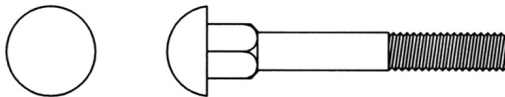

CARRIAGE BOLT

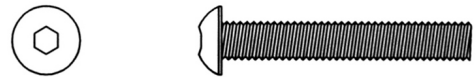

ALLEN BOLT



AIRCRAFT NUT



FLAT WASHER

ASSEMBLY INSTRUCTION

Tools Required Assembling the Machine: Two Adjustable Wrenches and Allen Wrenches
NOTE: It is strongly recommended two or people assembling this machine to avoid possible injury.

STEP 1 (See Diagram 1)

A.) Place the Right Base Frame (#46) and Left Base Frame (#87) on the floor, at a right angle to each other. Attach the Rear Vertical Beam (#50) to the joint and align the holes. Secure the holes with two M10 x 3" Carriage Bolts (#64), \varnothing 3/4" Washers (#6) and M10 Aircraft Nuts (#5). DO NOT tighten all the nuts and bolts yet.

Diagram 1

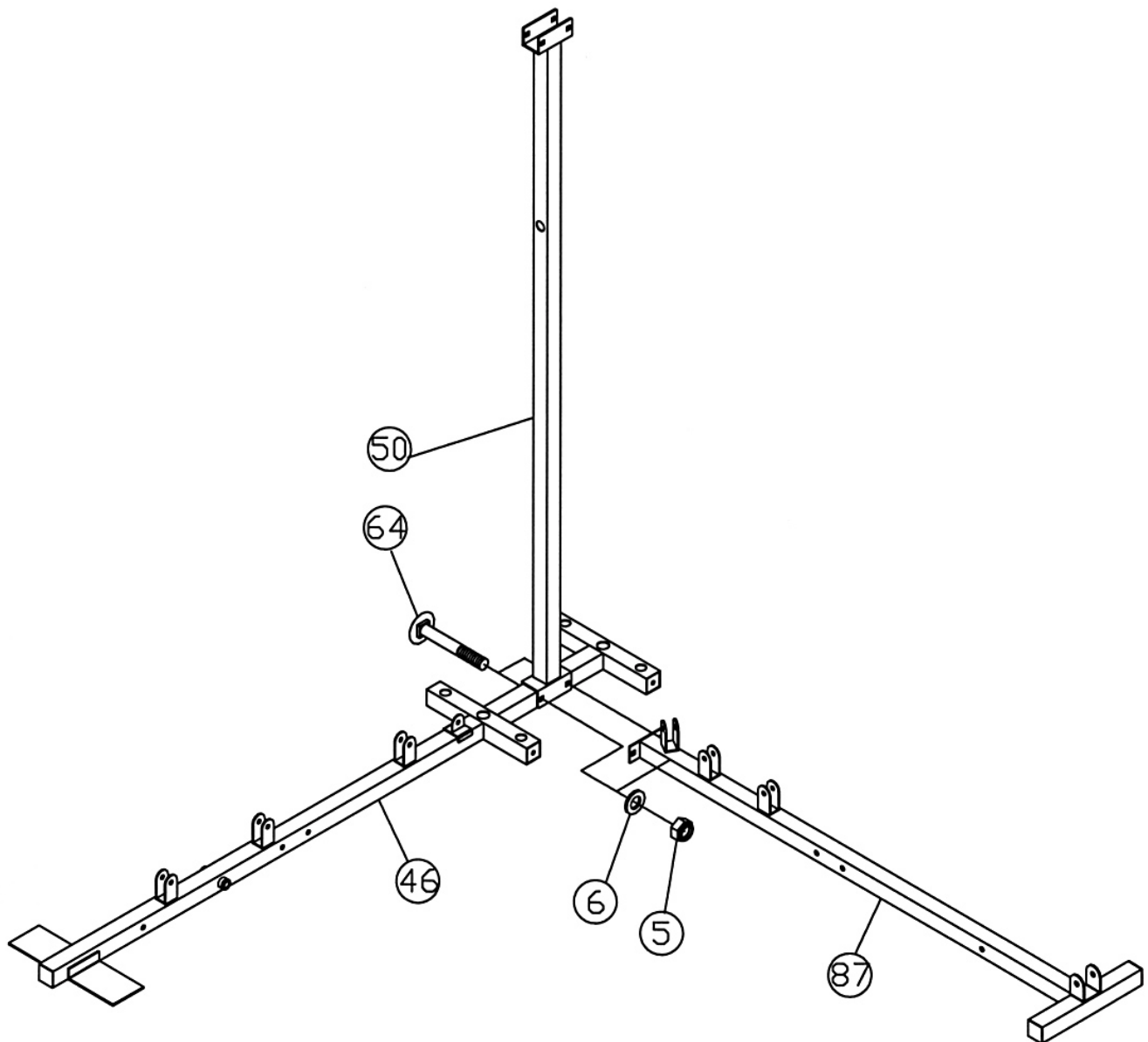

STEP 2 (See Diagram 2)

- A.) Attach the Right Vertical Beam (#21) to the Right Base Frame (#46). Secure it with two M10 x 2 3/4" Carriage Bolts (#17), \varnothing 3/4" Washers (#6), and M10 Aircraft Nuts (#5).
- B.) Attach the Right Seat Support (#49) to the Right Vertical Beam (#21). Secure it with one Bracket (#7), two M10 x 2 3/4" Carriage Bolts (#17), \varnothing 3/4" Washers (#6), and M10 Aircraft Nuts (#5).
- C.) Attach the other end of Right Seat Support (#49) to the Right Base Frame (#46). Secure it with one M10 x 2 1/2" Carriage Bolt (#100), \varnothing 3/4" Washer (#6), and M10 Aircraft Nut (#5).
- D.) Attach the Leg Developer (#40) to the front open bracket on the Right Seat Support. Secure it with a Leg Developer Axle (#41), two \varnothing 3/4" Washers (#6), and M10 x 3/4" Allen Bolts (#37).

DIAGRAM 2

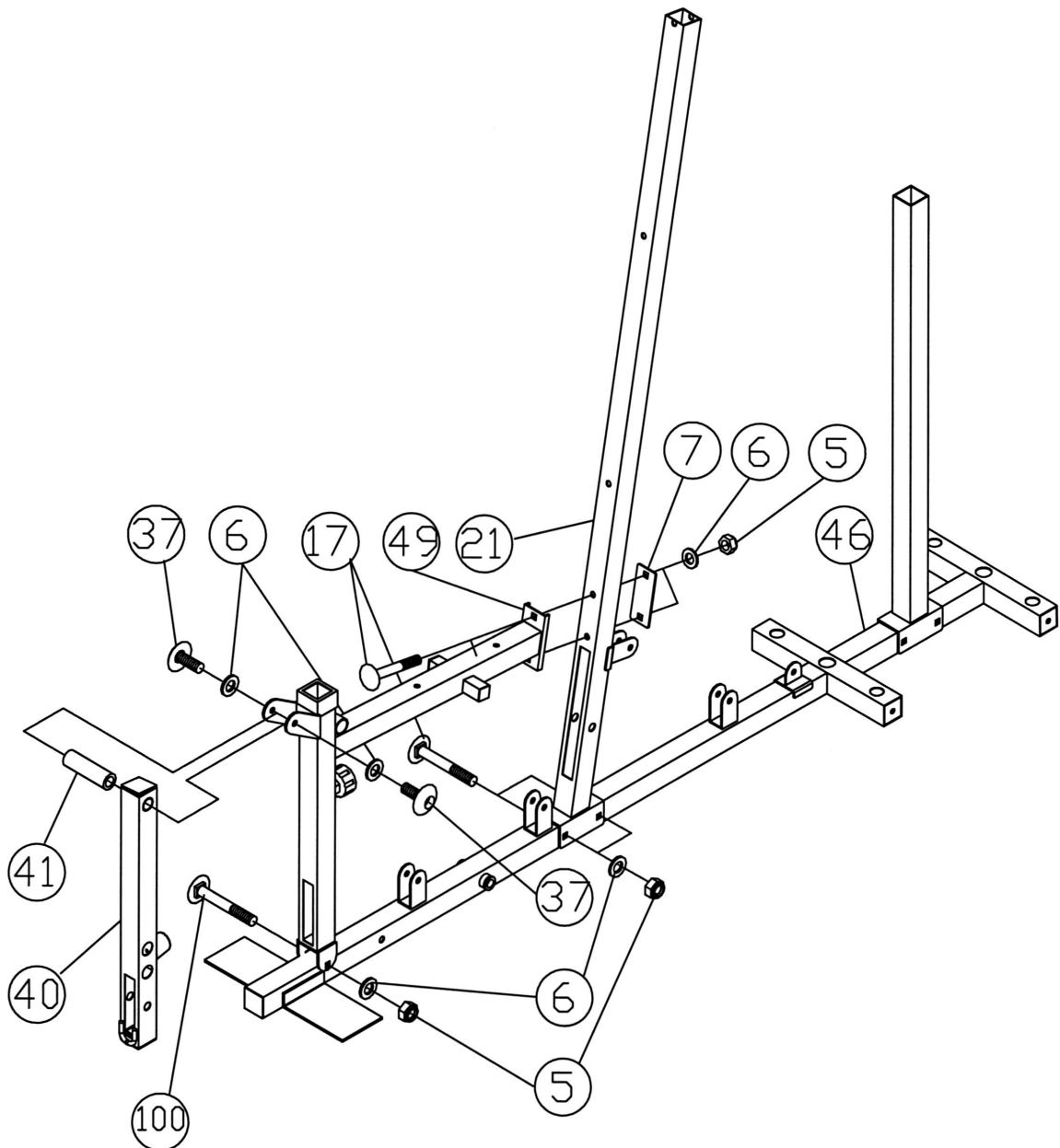

STEP 3 (See Diagram 3)

- A.) Slide two \varnothing 2 1/2" Rubber Bumpers (#58) onto two Chromed Guide Rods (#58). Insert the two Guide Rods into the holes on the Right Base Frame (#46). Slide the Selector Stem (#67) onto the two Guide Rods (#22). Slide the Selector Stem over the Selector Rod (#69). Secure the Selector Rod to the Selector Stem with two M10 x 1" Allen Bolts (#56). DO NOT install the plates yet.
- B.) Repeat the Procedure A above to install another set of Guide Rods.
- C.) Place the Upper Frame (#8) over the two sets of Guide Rods then onto top of Right Vertical Beam (#21) and Rear Vertical Beam (#50).
- D.) Secure each set of Guide Rods (#22) to the Upper Frame with two M10 x 1" Allen Bolts (#56) and \varnothing 3/4" Washers (#6).
- E.) Secure the Right Vertical Beam (#21) to the Upper Frame with one Bracket (#7), two M10 x 2 3/4" Carriage Bolts (#17), \varnothing 3/4" Washers (#6), and M10 Aircraft Nuts (#5).
- F.) Attach top of Left Vertical Beam (#77) to the Upper Frame. Attach the bottom of Left Vertical Beam to the Left Base Frame (#87). Secure the bottom of Left Vertical Beam with two M10 x 2 3/4" Carriage Bolts (#17), \varnothing 3/4" Washers (#6), and M10 Aircraft Nuts (#5).
- G.) Secure the Left Vertical Beam (#77), Rear Vertical Beam (#50), and Upper Frame (#8) all together with two M10 x 3" Carriage Bolts (#64), \varnothing 3/4" Washers (#6), and M10 Aircraft Nuts (#5).
- H.) Attach the Left Seat Support (#92) to the Left Vertical Beam (#77). Secure it with one Bracket (#7), two M10 x 2 3/4" Carriage Bolts (#17), \varnothing 3/4" Washers (#6), and M10 Aircraft Nuts (#5). Attach the other end of Left Seat Support (#92) to the Left Base Frame (#87). Secure it with one M10 x 2 1/2" Carriage Bolt (#100), \varnothing 3/4" Washer (#6), and M10 Aircraft Nut (#5).
- I.) Securely tighten all nuts and bolts previously installed.
- J.) Carefully tilt the machine on its side. (Help of another person is a MUST.) Secure the four Guide Rods (#22) to the Right Base Frame (#46) with four M10 x 1" Allen Bolts (#56).
- K.) Attach the bottom of Leg Press Frame (#84) to the bracket on the Left Base Frame (#87). Secure it with a M12 x 3" Allen Bolt (#89), two \varnothing 7/8" Washers (#71), and one M12 Aircraft Nut (#57).
- L.) Attach a Leg Press Diagonal Support (#90) to each side of the Leg Press Frame. Secure them together with two M10 x 2 1/2" Allen Bolts (#10), four \varnothing 3/4" Washers (#6), and two M10 Aircraft Nuts (#5).

DIAGRAM 3

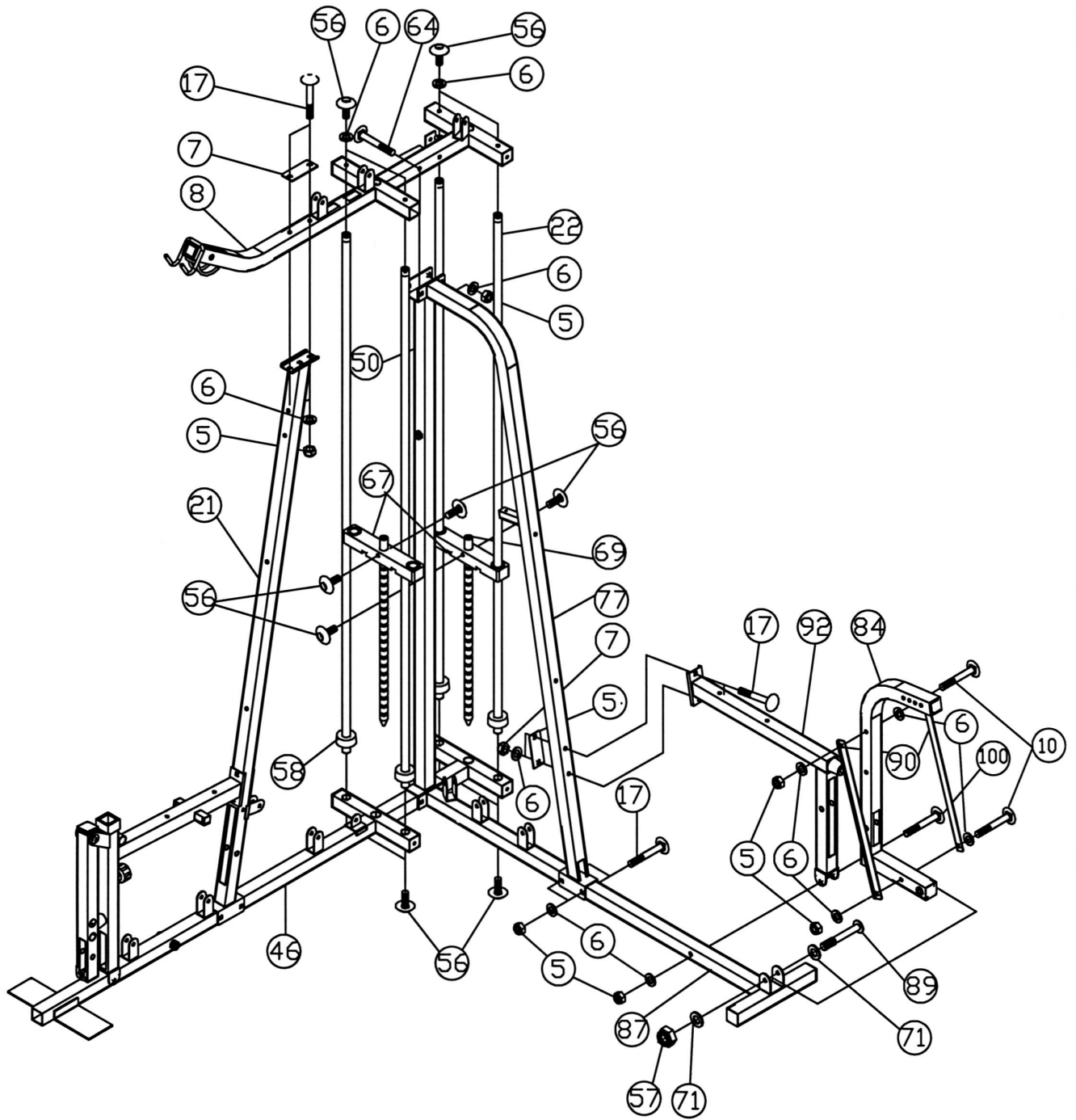

STEP 4 (See Diagram 4)

- A.) Attach the Front Press Base (#97) to the Right Base Frame (#46). Secure it with a 9 ¼" Front Press Axle (#60), two Ø ¾" Washers (#6), and two M10 Aircraft Nuts (#5).
- B.) Attach the Front Press Frames (#63) to the Front Press Base. Secure it with four M10 x 2 ¾" Carriage Bolts (#17), Ø ¾" Washers (#6), and M10 Aircraft Nuts (#5).

DIAGRAM 4

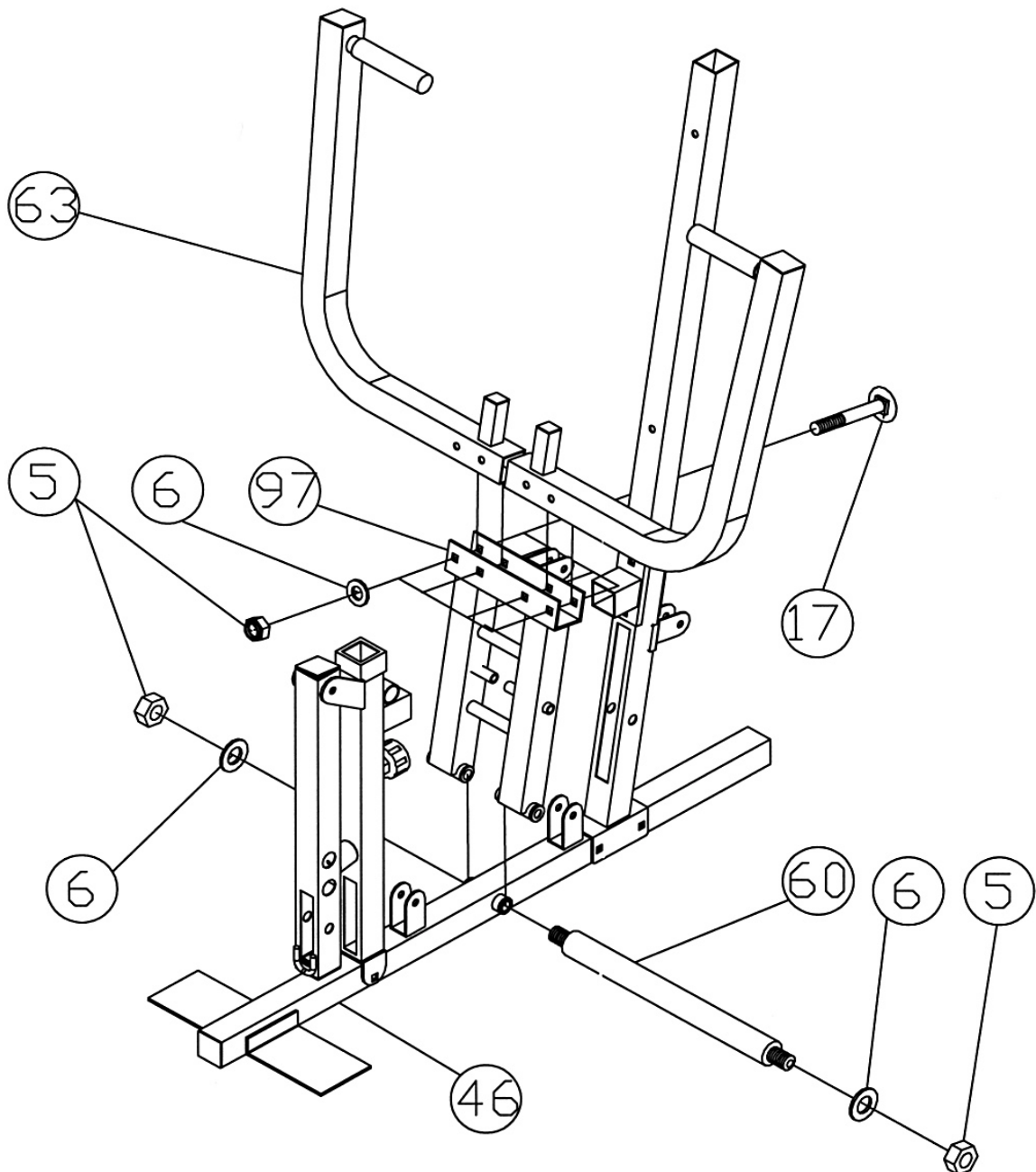

STEP 5 (See Diagram 5)

- A.) Attach the Butterfly Support Frame (#18) to the front of Right Vertical Beam (#21). Attach the Butter Pulley Support (#74) to the back of Right Vertical Beam. Align the holes. Secure them together with two M10 x 2 3/4" Carriage Bolts (#17), \varnothing 3/4" Washers (#6), and M10 Aircraft Nuts (#5).
- B.) Insert the Axle on the Left Butterfly (#20) into the hole on the Butterfly Support Frame from the bottom. Secure it with one \varnothing 1 1/2" Washer (#16), \varnothing 1 1/2" Lock Ring (#13), M6 x 1 3/8" Hex Socket Bolt (#12), and M6 Aircraft Nut (#14). Repeat the same procedure to install the other side.
- C.) Slide two Butterfly Foam Rolls (#27) onto the Butterfly Arms.
- D.) Attach a Swivel Pulley Bracket (#72) to the bottom of the Butterfly Pulley Support (#74). Secure it with a M12 x 4 1/2" Allen Bolt (#70), two 7/8" Washers (#71), and one M12 Aircraft Nut (#57). Repeat for the other side.

DIAGRAM 5

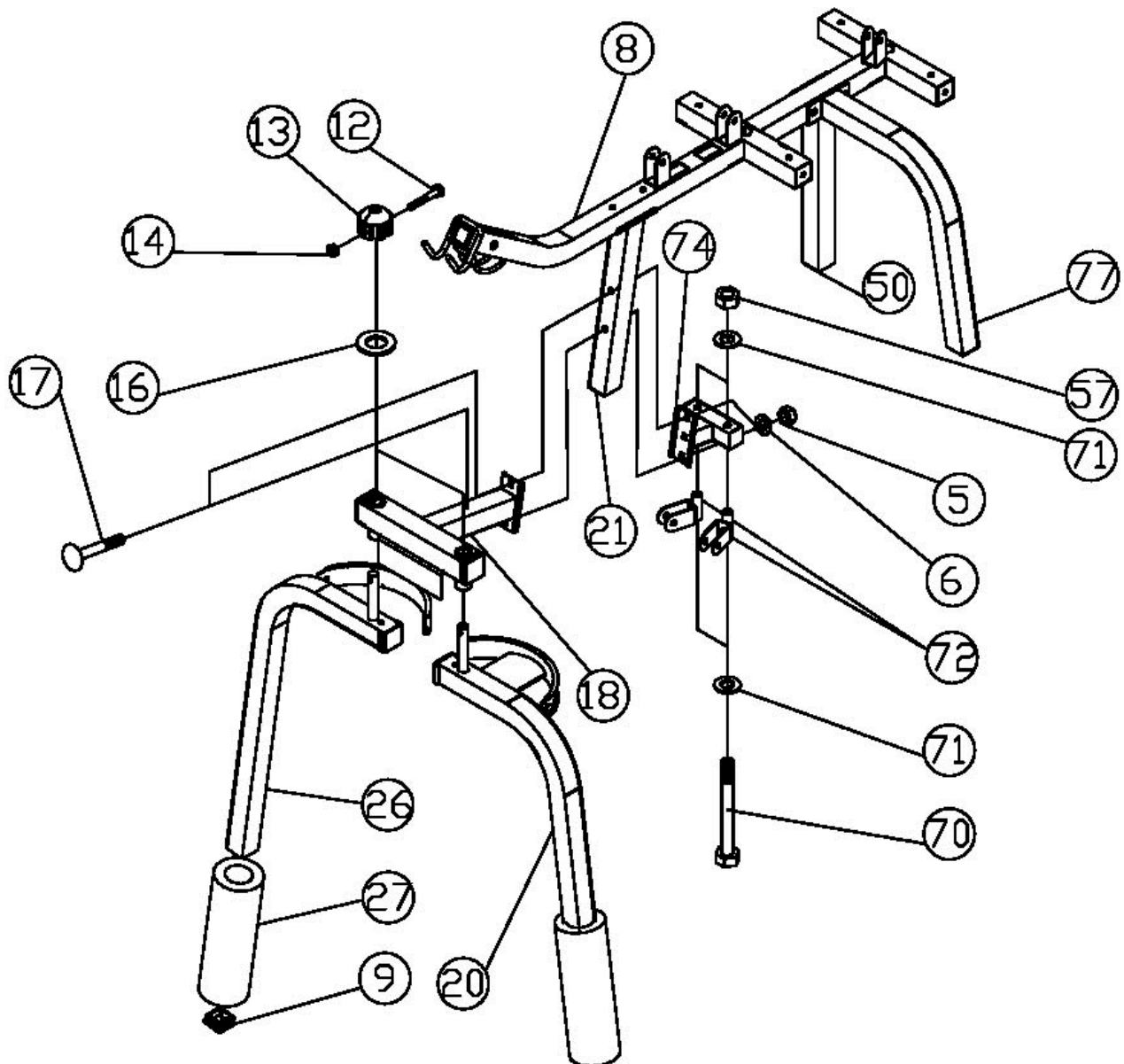

STEP 6 (See Diagram 6)

- A.) Attach the Vertical Press Frame (#78) to the Rear Vertical Beam (#50). Secure it with a M10 x 4 7/8" Vertical Press Axle (#81), two $\varnothing \frac{3}{4}$ " Washers (#6), and two M10 x 1" Allen Bolts (#56).
- B.) Place the Vertical Press Frame rest onto the $\varnothing 1 \frac{1}{2}$ " Rubber Bumper (#83).

DIAGRAM 6

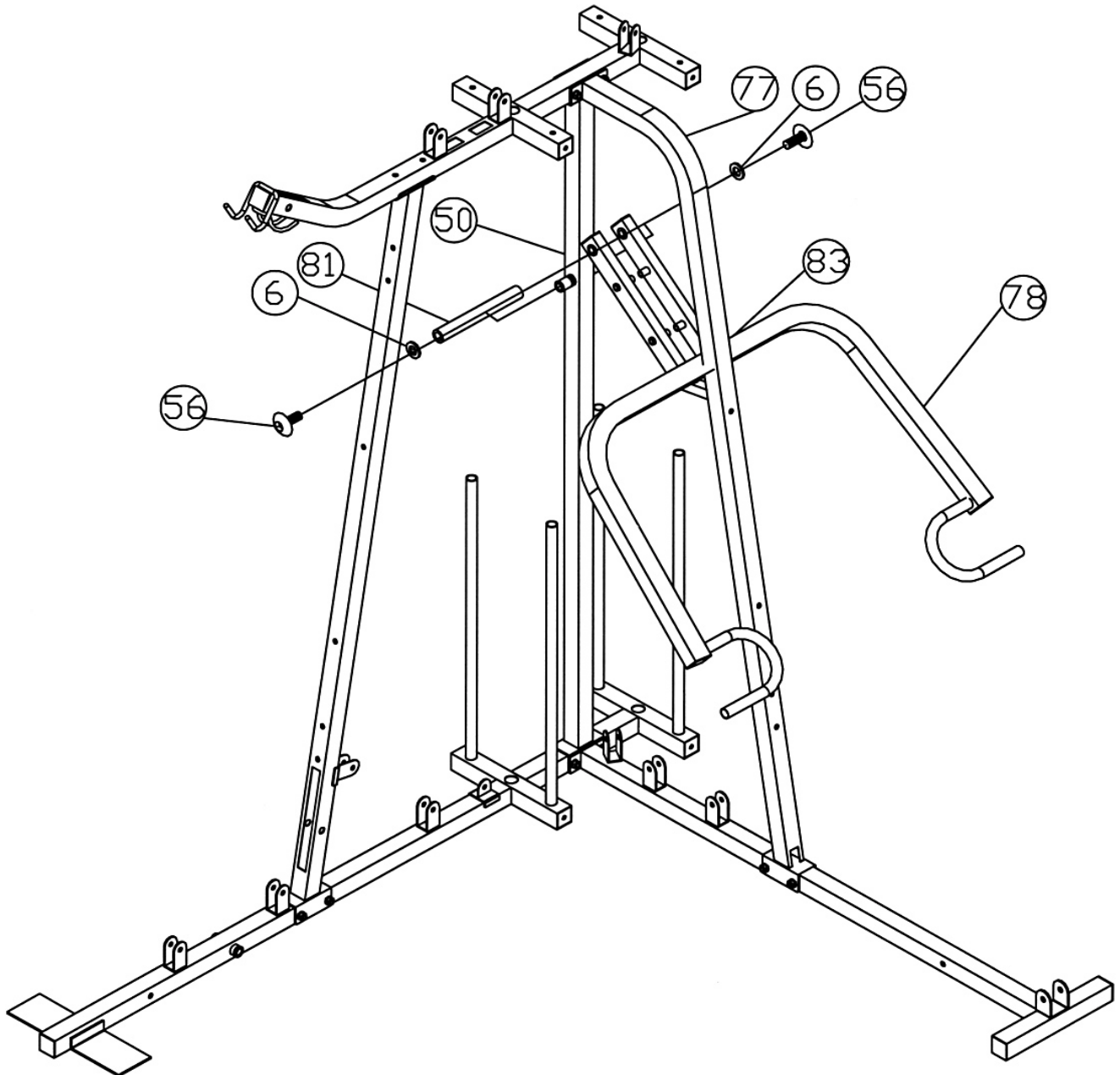

CABLE LOOP DIAGRAM

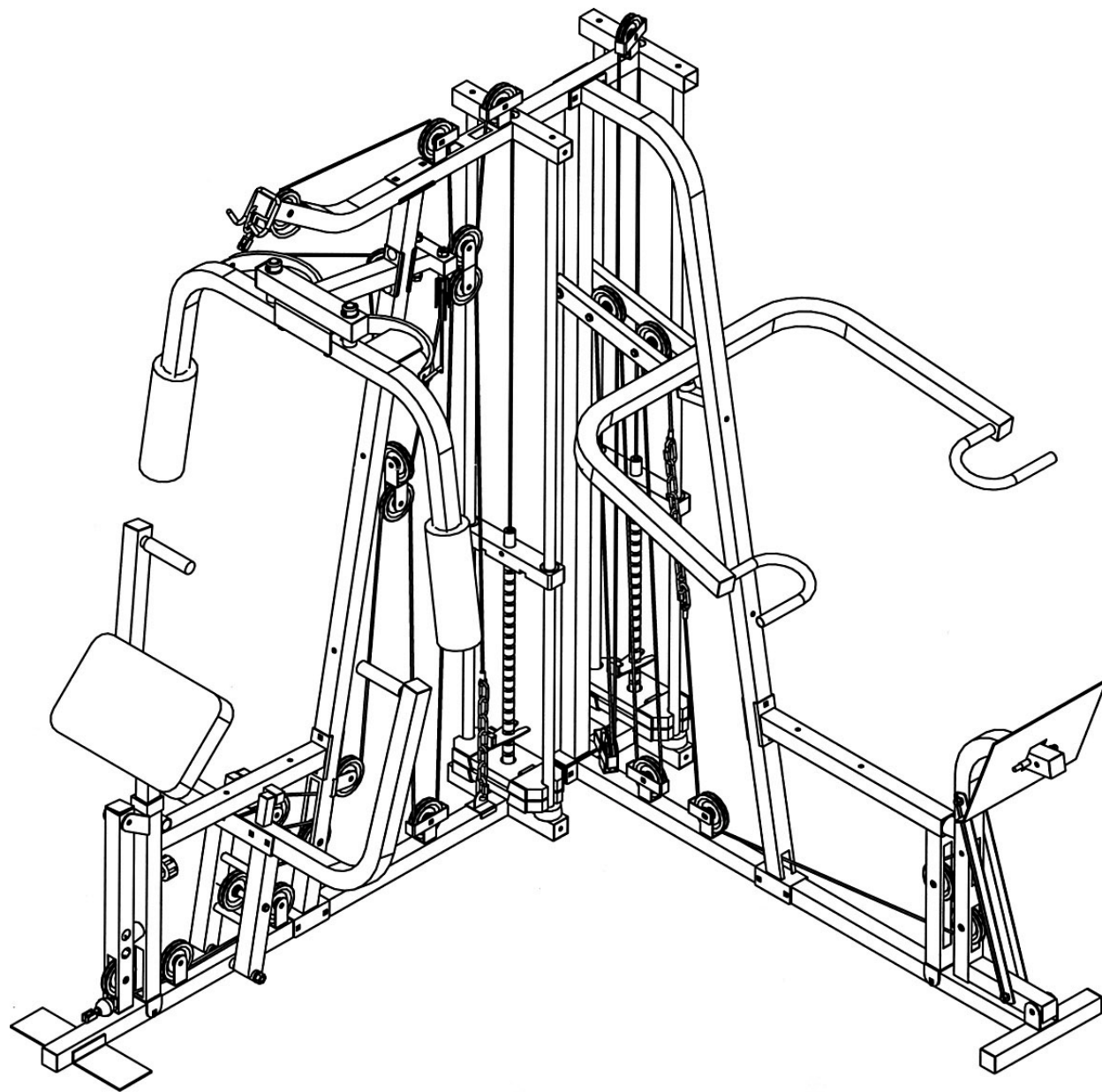

STEP 7 (Upper Cable Loop & Diagram 7)

- A.) Attach the 108" Upper Cable (#93) to the front opening on the Upper Frame (#8). Attach a Pulley (#79) to the opening. Secure it with one M10 x 2 1/2" Allen Bolt (#10), two Pulley Bushings (#11), and one M10 Aircraft Nut (#5). Draw the Cable towards the back of the machine. Note: Make sure the Ball Stopper is underneath the frame.
- B.) Attach a Pulley to the bracket on the Upper Frame. Secure it with one M10 x 2" Allen Bolt (#98), two \varnothing 3/4" Washers (#6), one L-shaped Pulley Bracket (#86), and one M10 Aircraft Nut (#5).
- C.) Pull the Cable downward. Install a Pulley with a U-shaped Pulley Bracket (#85) and a Flat Double Floating Pulley Bracket (#59). Let the bracket hanging for now.
- D.) Draw the Cable around the Pulley then upward to the second open bracket on the Upper Frame. Install another Pulley with a U-shaped Pulley Bracket (#85).
- E.) Draw the Cable around the Pulley then downward to the Selector Rod (#69). Securely thread the end of the Cable into the Selector Rod (#69).

UPPER CABLE LOOP DIAGRAM

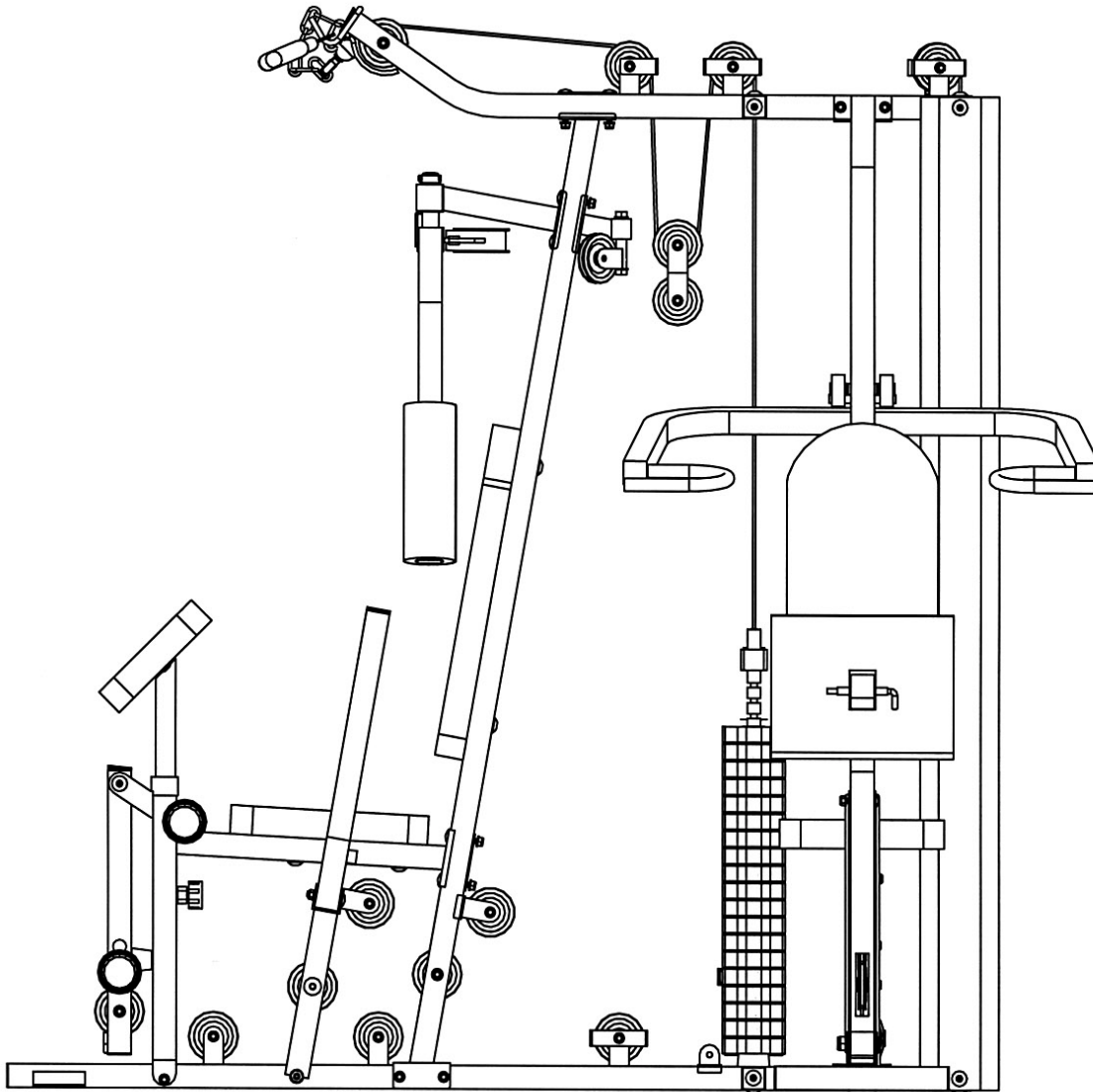
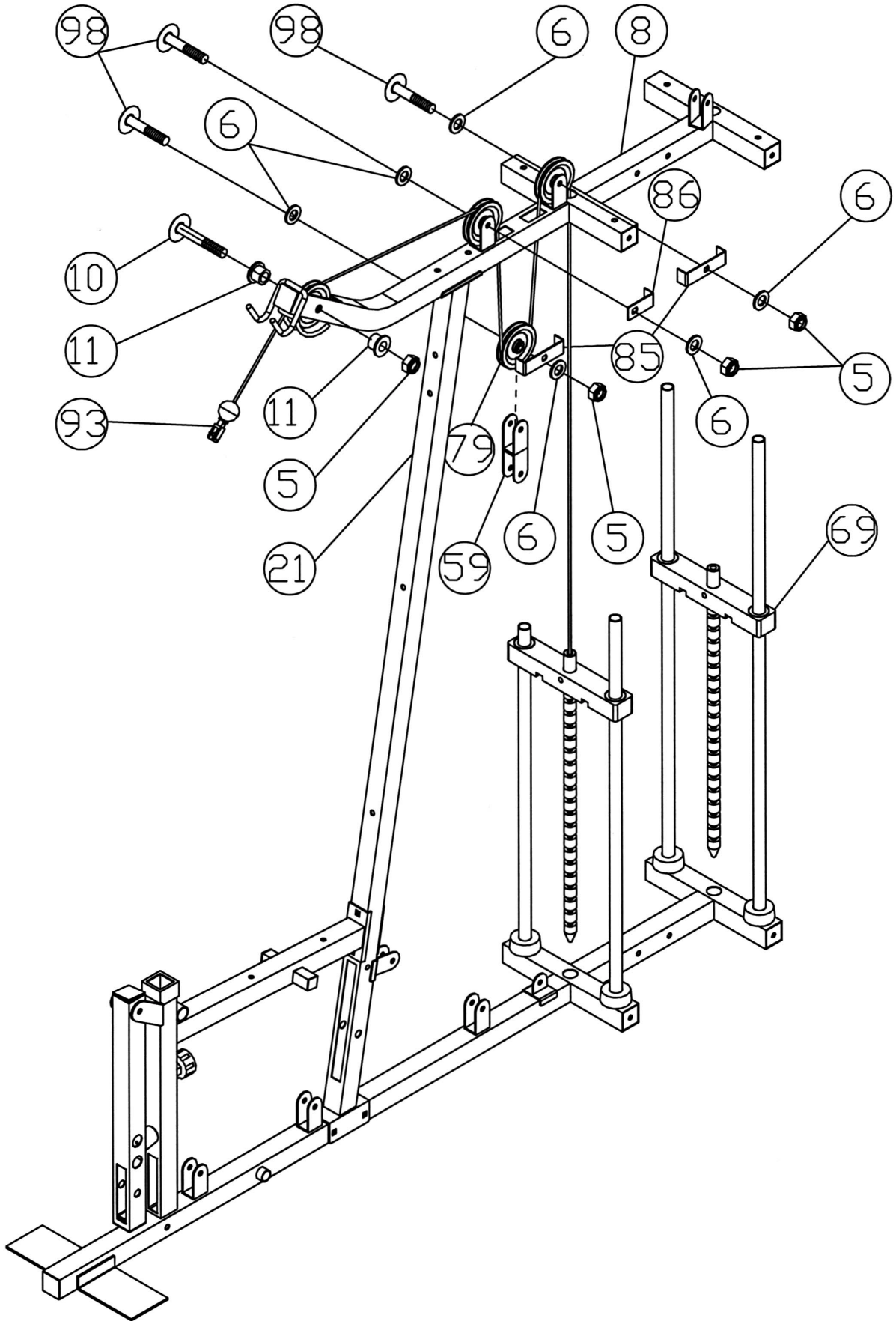

DIAGRAM 7



STEP 8 (See Butterfly Cable Loop & Diagram 8)

- A.) Attach the 106" Butterfly Cable (#95) to the slot on the back of Left Butterfly (#20). Draw the Cable through the slot then to the open left Swivel Pulley Bracket (#72).
- B.) Attach a Pulley (#79) to the bracket. Secure it with one M10 x 2" Allen Bolt (#98), two \varnothing 3/4" Washers (#6), and one M10 Aircraft Nut (#5).
- C.) Draw the Cable around the Pulley then downward. Install a Pulley to the Angled Double Floating Bracket (#51). Let the Bracket hanging for now.
- D.) Draw the Cable upward to the right Swivel Pulley Bracket. Install another Pulley..
- E.) Draw the Cable to the Right Butterfly (#26) and secure the cable end to the slot.

BUTTERFLY CABLE LOOP DIAGRAM

DIAGRAM 8

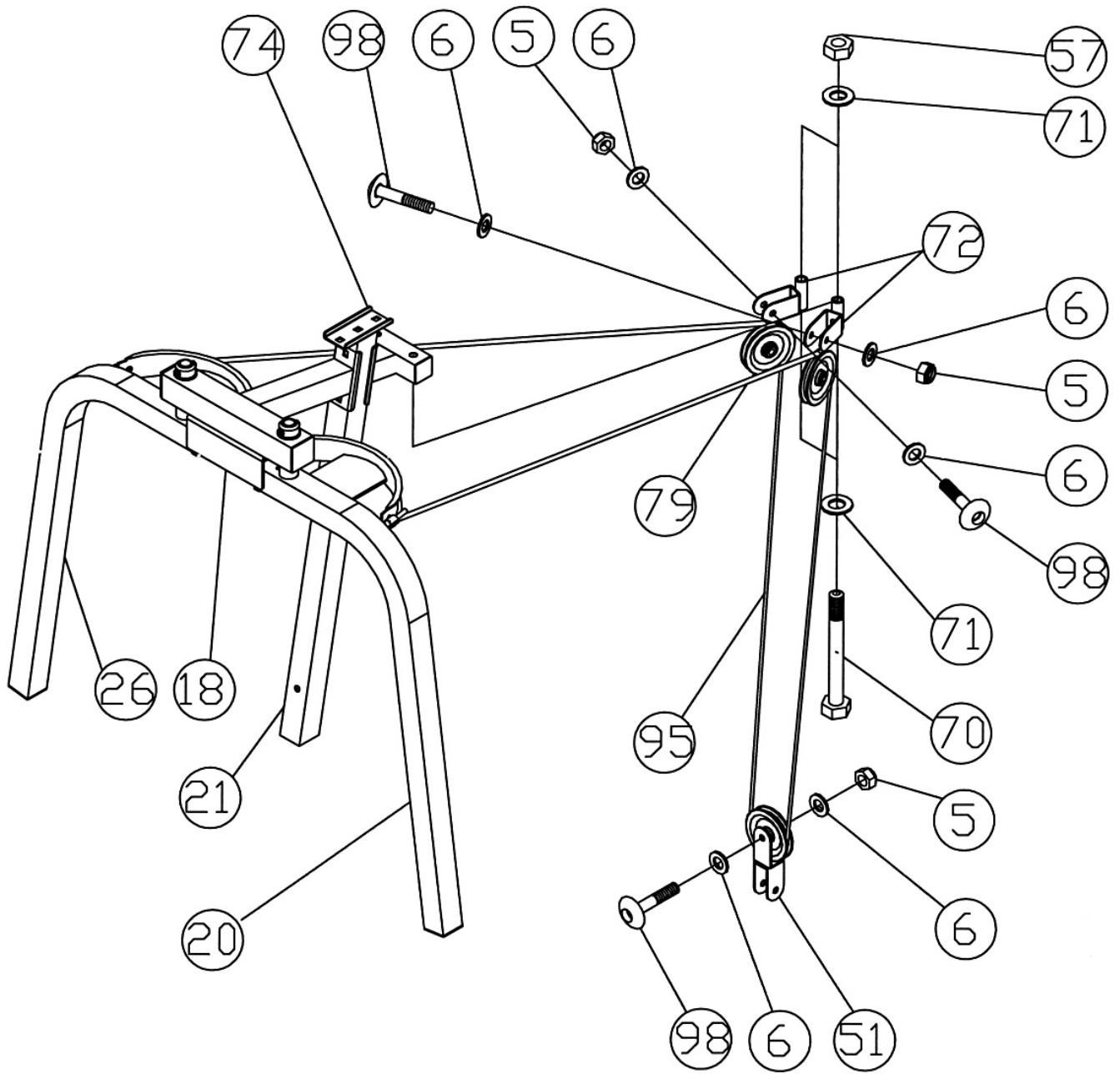

STEP 9 (See Front Press Cable Loop & Diagram 9)

- A.) Attach the 224" Front Press Cable (#94) to the lower opening on the Leg Developer (#40).
- B.) Attach a Pulley (#79) to the opening. Secure it with one M10 x 2 ½" Allen Bolt (#10), two Pulley Bushings (#11), and one M10 Aircraft Nut (#5).
- C.) Draw the Cable underneath the Pulley through the opening on the Right Seat Support (#49) to the open bracket on the Right Base Frame (#46).
- D.) Attach a Pulley to the bracket. Secure it with one M10 x 2" Allen Bolt (#98), two Ø ¾" Washers (#6), and one M10 Aircraft Nut (#5).
- E.) Continue drawing the Cable along the Right Base Frame to another open bracket. Install a Pulley as described in Step D above. Draw the Cable around the Pulley then back to the opening between the Front Press Base (#97).
- F.) Attach a Pulley to the opening. Secure it with one M10 x 8 ¼" Allen Bolt (#62), two Ø ¾" Washers (#6), and one M10 Aircraft Nut (#5).
- G.) Draw the Cable around the Pulley then back to the lower opening on the Right Vertical Beam (#21). Install a Pulley with one M10 x 2 ½" Allen Bolt (#10), two Pulley Bushings (#11), and one M10 Aircraft Nut (#5). Draw the Cable back to the open bracket on the back of Front Press Base.
- H.) Install another Pulley as described in Step D above. Draw the Cable back through the lower opening on the Right Vertical Beam (#21) to the open bracket on the back of the Beam. Install another Pulley.
- I.) Draw the Cable upward to the hanging Angled Double Floating Bracket (#51) previously installed in STEP 8. Install another Pulley. Draw the Cable downward to the open bracket on the Right Base Frame (#46). Install another Pulley with a U-shaped Pulley Bracket (#85).
- J.) Draw the Cable upward to the hanging Flat Double Floating Pulley Bracket (#59) previously installed in STEP 7. Install another Pulley with a U-shaped Pulley Bracket (#85).
- K.) Draw the Cable around the Pulley then downward and connect to the Right Base Frame with a Chain (#3) and two C-clips (#4). Adjust the tension of the Cable by adjusting the length of the Chain.

FRONT PRESS CABLE LOOP DIAGRAM

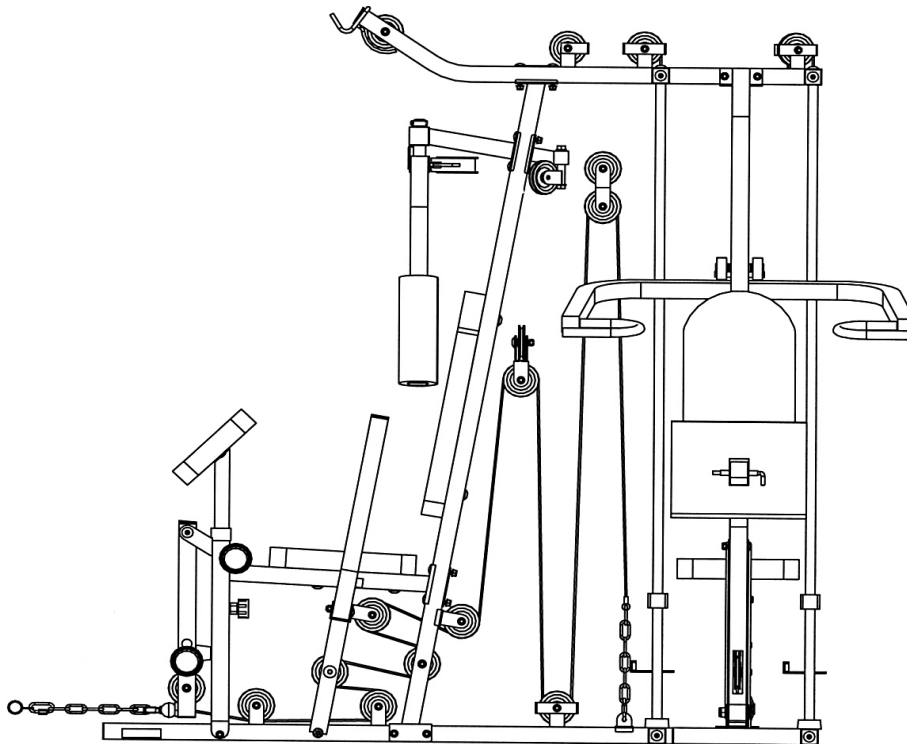
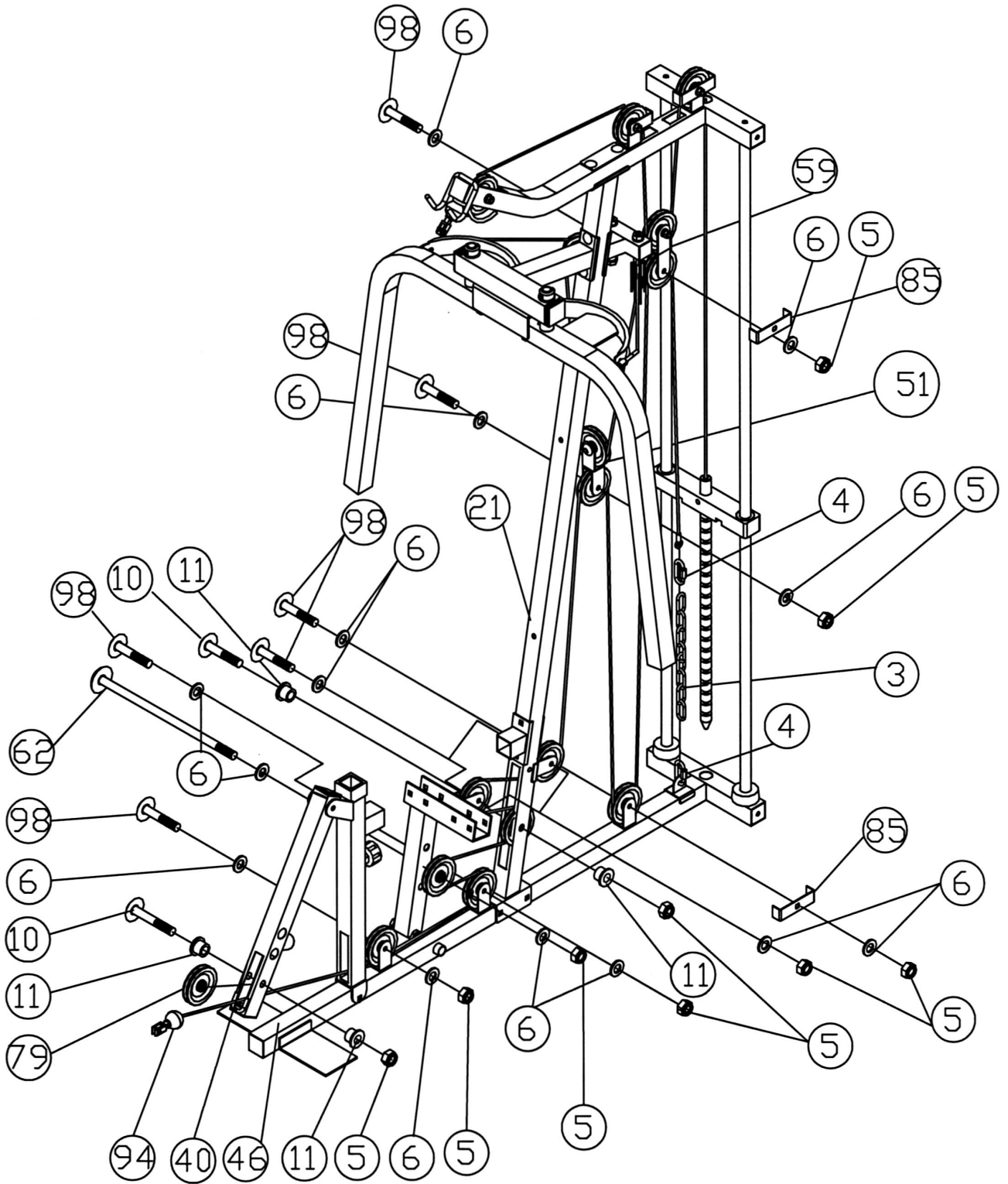

DIAGRAM 9



STEP 10 (See Leg Press Cable Loop & Diagram 10)

- A.) Attach one end of the 82" Leg Press Cable (#96) to the open slot on the back of the Leg Press Frame (#84). Secure it with one M10 x 2 1/2" Allen Bolt (#10), two Ø 3/4" Washers (#6), and one M10 Aircraft Nut (#5).
- B.) Draw the Cable to the front opening on the Left Seat Support (#92). Attach a Pulley to the opening. Secure it with one M10 x 2 1/2" Allen Bolt (#10), two Pulley Bushings (#11), and one M10 Aircraft Nut (#5).
- C.) Draw the Cable around the Pulley then back to the lower opening on the Leg Press Frame. Install a Pulley as described in Step B above.
- D.) Draw the Cable around the Pulley then towards back of the machine through the hole on the bottom of the Left Vertical Beam (#77) to the open bracket on the Left Base Frame (#87).
- E.) Attach a Pulley to the bracket. Secure it with one M10 x 2" Allen Bolt (#98), two Ø 3/4" Washers (#6), one L-shaped Pulley Bracket (#86), and one M10 Aircraft Nut (#5).
- F.) Pull the Cable upward and connect to the 298" Vertical Press Cable (#102) with two C-clips (#4) and one Chain (#3). After completing the steps, adjust the length of this Chain to adjust the tightness of the Cables.
- G.) Draw the Vertical Press Cable to the opening between the Vertical Press Frame (#78). Attach a Pulley to the opening. Secure it with one M10 x 5 3/4" Allen Bolt (#82), two Ø 3/4" Washers (#6), and one M10 Aircraft Nut (#5).
- H.) Draw the Cable around the Pulley and downward to the middle open bracket on the Left Base Frame. Install a Pulley with a U-shaped Pulley Bracket (#85).
- I.) Pull the Cable upward back to the opening on the Vertical Press Frame. Install another Pulley as described in Step G above.
- J.) Draw the Cable downward to the last open bracket on the rear of the Left Base Frame. Install a Pulley with a U-shaped Pulley Bracket (#85).
- K.) Draw the Cable upward to the last open bracket on the Upper Frame (#8). Install another Pulley. Draw the Cable downward and securely threaded it into the Selector Rod.

LEG PRESS CABLE LOOP DIAGRAM

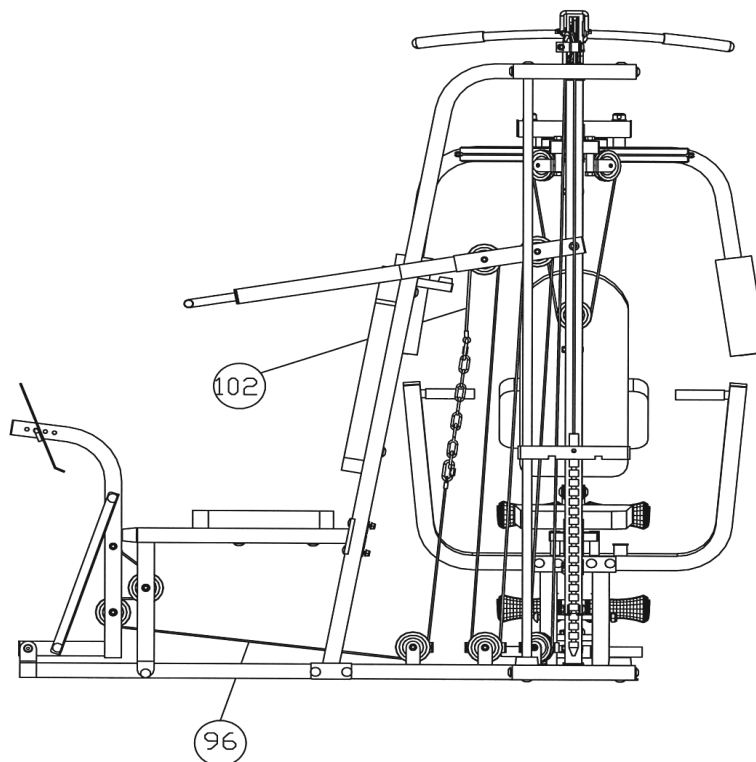
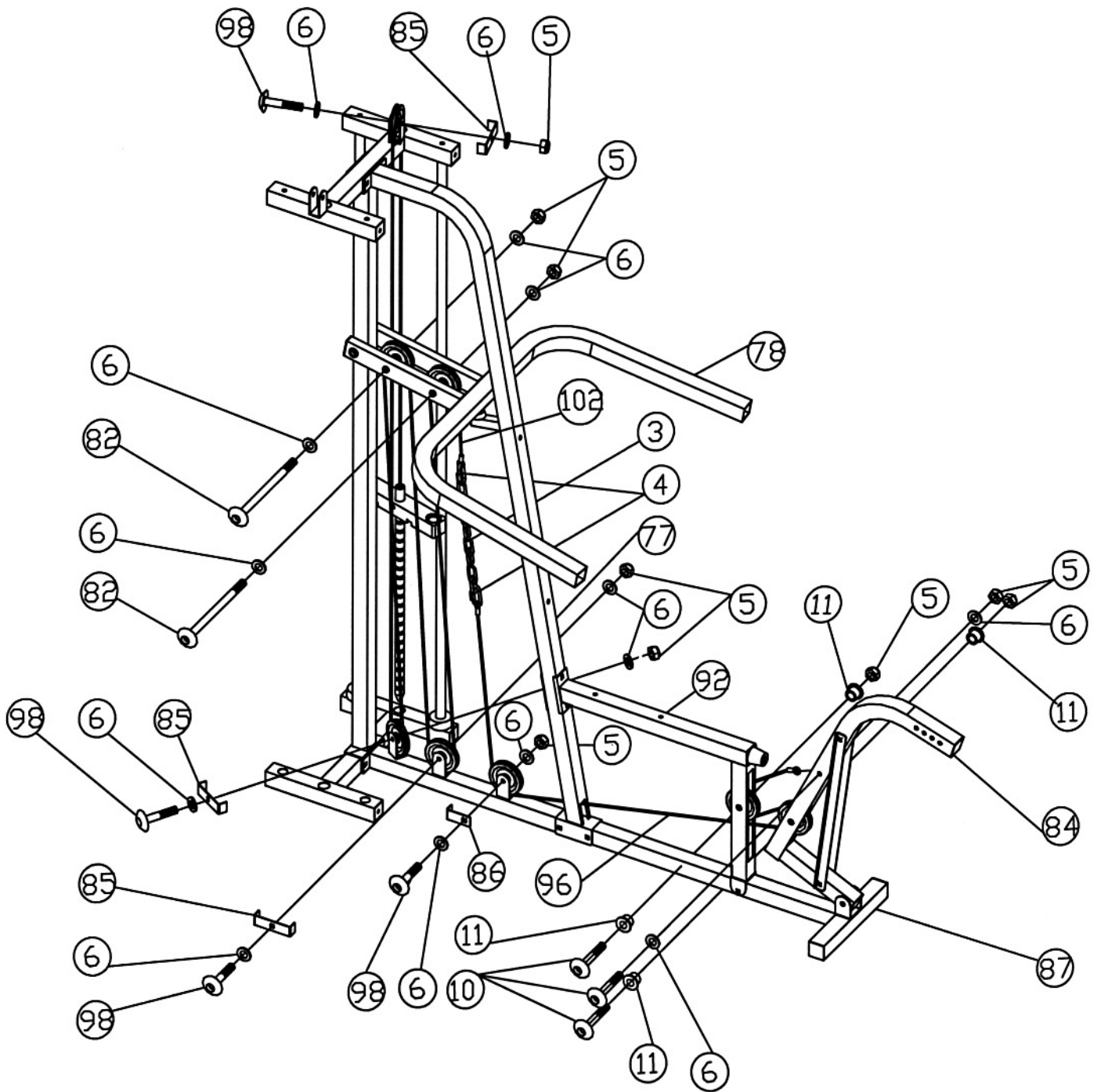

DIAGRAM 10



STEP 11 (See Diagram 11)

- A.) Place a Seat Pad (#29) onto the Left Seat Support (#92). Secure it with two M8 x 2 1/8" Allen Bolts (#25) and \varnothing 5/8" Washers (#24).
- B.) Attach a Backrest Board (#28) to the Left Vertical Beam (#77). Secure it with two M8 x 2 1/8" Allen Bolts (#25) and \varnothing 5/8" Washers (#24).
- C.) Attach the Leg Press Plate (#76) onto the Leg Press Frame (#84). Secure it with a L-shaped Pin (#75).

DIAGRAM 11

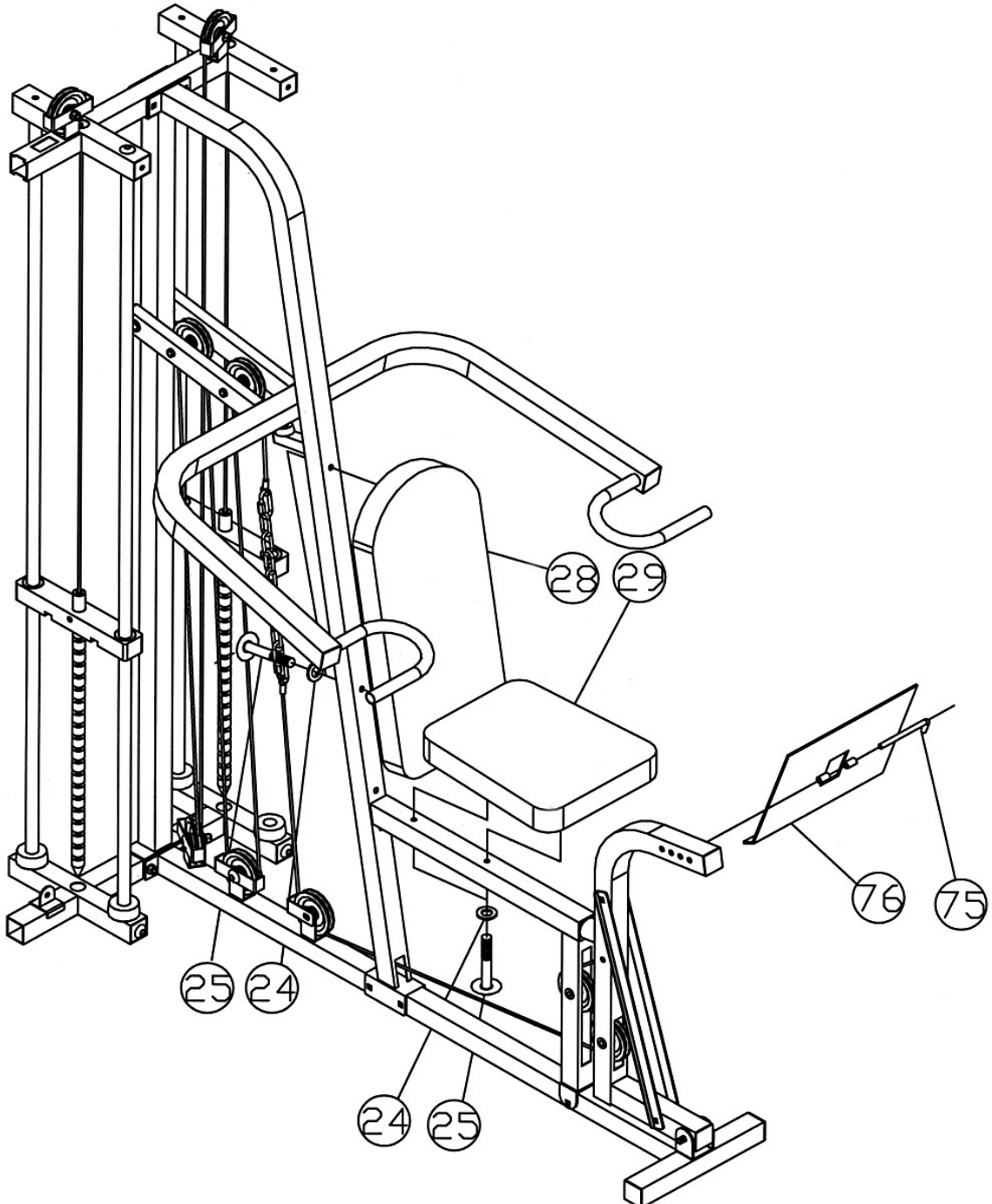

STEP 12 (See Diagram 12)

- A.) Place a Seat Pad (#29) onto the Right Seat Support (#49). Secure it with two M8 x 2 1/8" Allen Bolts (#25) and \varnothing 5/8" Washers (#24).
- B.) Attach a Backrest Board (#28) to the Right Vertical Beam (#21). Secure it with two M8 x 2 1/8" Allen Bolts (#25) and \varnothing 5/8" Washers (#24).
- C.) Insert two Foam Roll Tubes (#36) halfway through the holes on the Right Seat Support (#49) and Leg Developer (#40). Push four Foam Rolls (#33) onto the Tubes from both sides. Plug four \varnothing 1" Round End Caps (#32) into the ends.
- D.) Attach the Arm Curl Pad (#34) to the Arm Curl Stand (#35). Secure it with two M8 x 5/8" Allen Bolts (#31) and \varnothing 5/8" Washers (#24). Insert the Arm Curl Stand into the opening in front of the seat. Use the Lock Knob (#47) on the Right Seat Support to obtain the desired position.
- E.) Connect the Lat Bar (#2) to the Upper Cable with a C-clip (#4) and a Chain (#3).
- F.) Connect the Arm Curl Handle (#44) to the Front Press Cable (#94) with a C-clip (#4) and a Chain (#3).

DIAGRAM 12

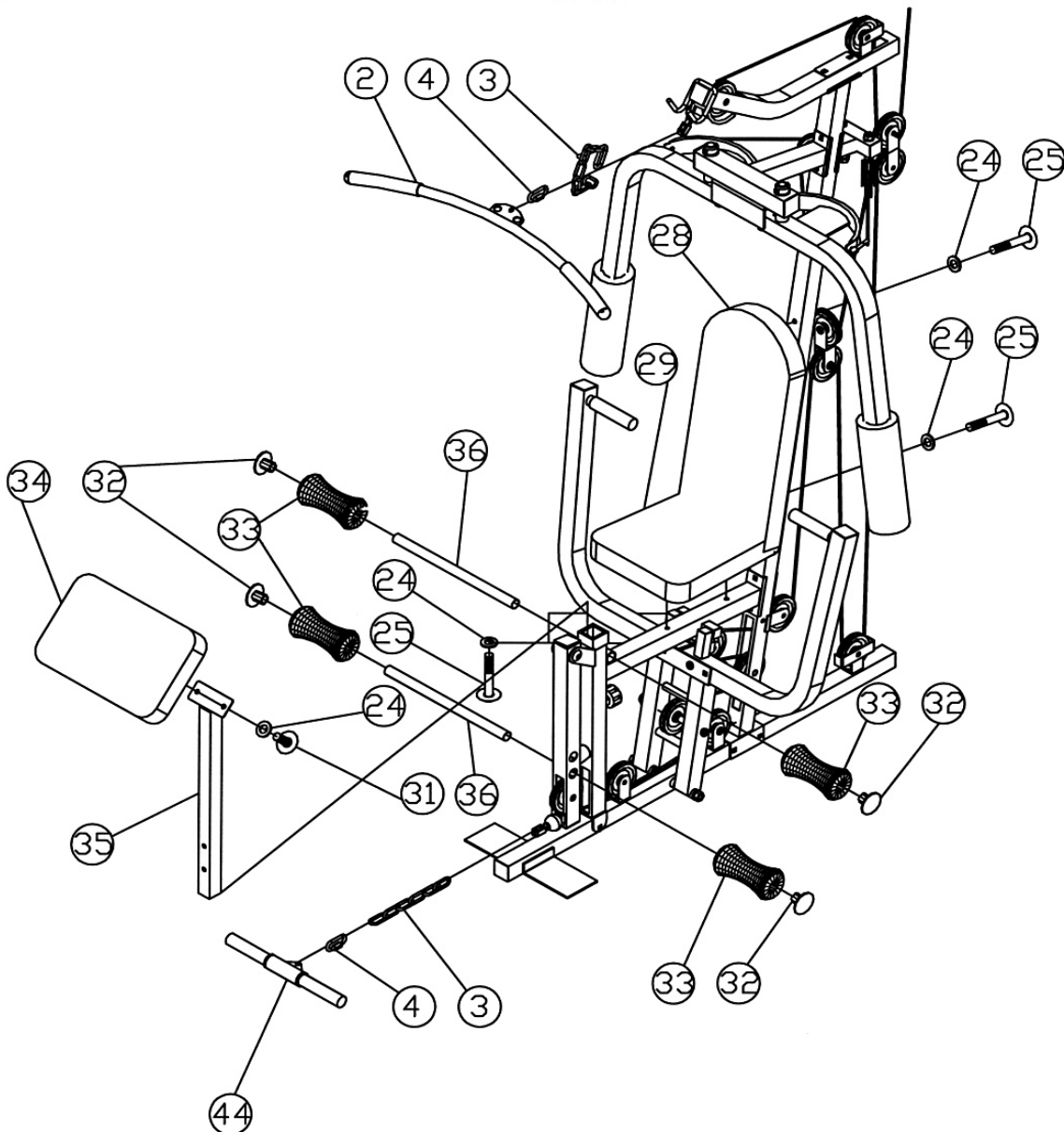

STEP 13 (See Diagram 13)

- A.) Securely tighten all the nuts and bolts previously installed.
- B.) Before putting the Weight Plates on, now move the machine to the corner of the room or place where you will use the machine.
- C.) Lift up the Selector Rod and install one stack of 19 Weight Plates (#66). To install the plates, hold the plate at an angle and place between the two Guide Rods then drop it down. Make sure the grooves on the plastic covers all face up. All the Plates should interlock with each other. See diagram below. It is strongly recommended to spray some lubricant such as WD-40 on the two Guide Rods to minimize friction. Use the Selector Pin (#55) to select the desired weights. The Magnet on the Pin should face up. Repeat the same procedure to install another stack of Weight Plates.
- D.) Attach four Weight Stack Covers (#23) to the machine and secure each Weight Stack Cover with two M10 x 1" Allen Bolts (#56) and \varnothing 3/4" Washers (#6).

DIAGRAM 13

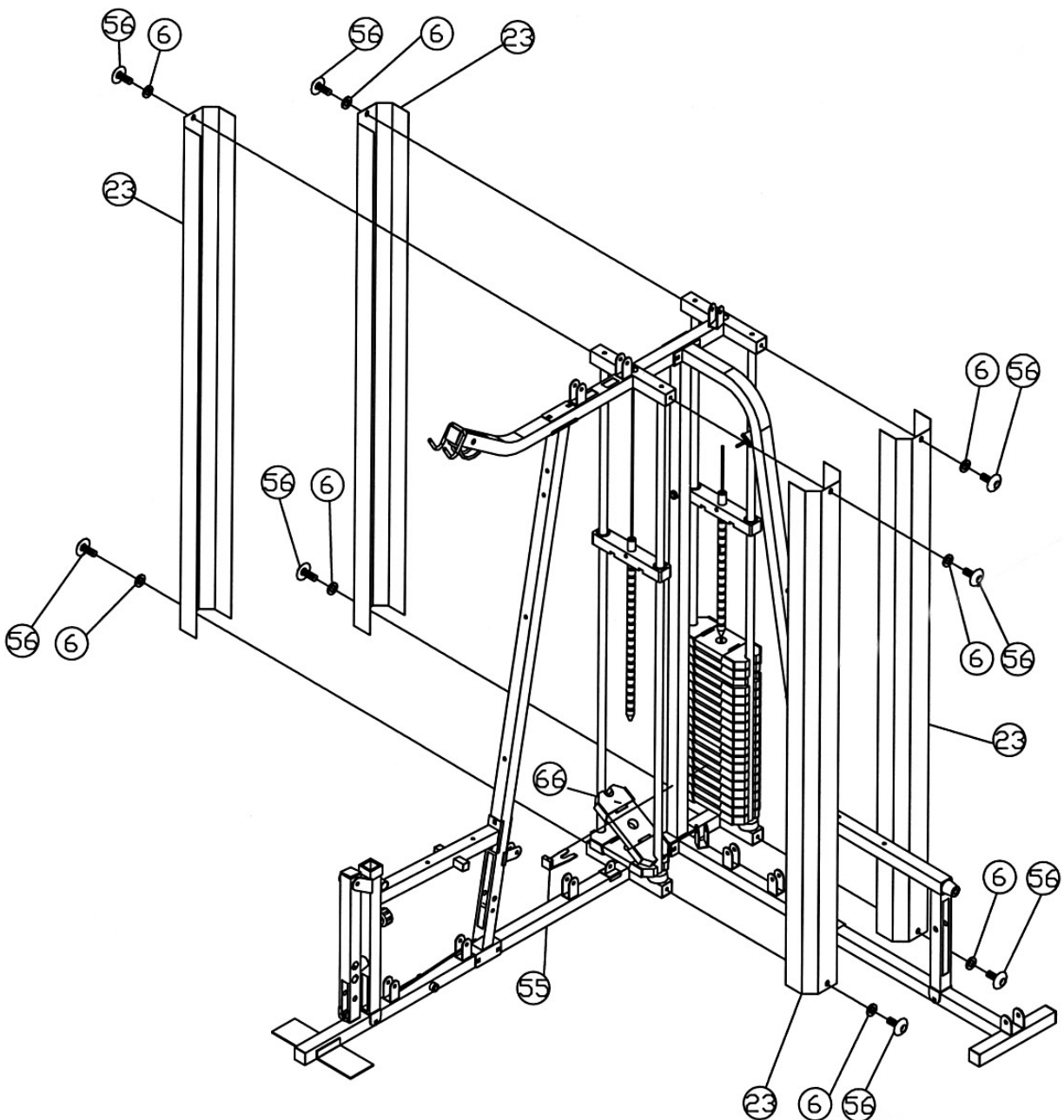

PARTS LIST

KEY NO.	DESCRIPTION	Q'ty			
1	Lat Bar Grip	2	52	M5 Screw	2
2	Lat Bar	1	53	Magnet Box	2
3	Chain	4	54	Magnet	2
4	C-clip	6	55	Selector Pin	2
5	M10 Aircraft Nut	52	56	M10 x 1" Allen Bolt	22
6	Ø ¾" Washer	86	57	M12 Aircraft Nut	3
7	Bracket	3	58	Ø 2 ½" Rubber Bumper	4
8	Upper Frame	1	59	Flat Double Floating Pulley Bracket	1
9	1 ¾" Square End Cap	17	60	9 ¼" Front Press Axle	1
10	M10 x 2 ½" Allen Bolt	8	61	Ø 7/8" Metal Bushing	14
11	Pulley Bushing	10	62	M10 x 8 ¼" Allen Bolt	1
12	M6 x 1 3/8" Hex Socket Bolt	2	63	Front Press Frame	2
13	Ø1 1/2" Lock Ring	2	64	M10 x 3" Carriage Bolt	4
14	M6 Aircraft Nut	2	65	Weight Plate Cover	76
15	Butterfly Axle Sleeve	2	66	Weight Plate	38
16	Ø 1 ½" Washer	2	67	Selector Stem	2
17	M10 x 2 ¾" Carriage Bolt	16	68	Selector Stem Bushing	4
18	Butterfly Support Frame	1	69	Selector Rod	2
19	2" Square End Cap	2	70	M12 x 4 ½" Allen Bolt	2
20	Left Butterfly	1	71	Ø7/8" Washer	6
21	Right Vertical Beam	1	72	Swivel Pulley Bracket	2
22	Guide Rod	4	73	1 ½" Square End Cap	3
23	Weight Stack Cover	4	74	Butterfly Pulley Support	1
24	Ø 5/8" Washer	10	75	L-shaped Pin	1
25	M8 x 2 1/8" Allen Bolt	8	76	Leg Press Plate	1
26	Right Butterfly	1	77	Left Vertical Beam	1
27	Butterfly Foam Roll	2	78	Vertical Press Frame	1
28	Backrest Board	2	79	Pulley	25
29	Seat Pad	2	80	2" x 1" End Cap	2
30	2" Sleeve	1	81	M10 x 4 7/8" Vertical Press Axle	1
31	M8 x 5/8" Allen Bolt	2	82	M10 x 5 ¾" Allen Bolt	2
32	Ø 1" Round End Cap	4	83	Ø 1 ½" Rubber Bumper	1
33	Foam Roll	4	84	Leg Press Frame	1
34	Arm Curl Pad	1	85	U-shaped Pulley Bracket	7
35	Arm Curl Stand	1	86	L-shaped Pulley Bracket	2
36	Foam Roll Tube	2	87	Left Base Frame	1
37	M10 x ¾" Allen Bolt	2	88	Ø 7/8" x Ø 5/8" Leg Press Bushing	2
38	Ø 1 5/8" Rubber Bumper	2	89	M12 x 3" Allen Bolt	1
39	M6 x 5/8" Philips Screw	2	90	Leg Press Diagonal Support	2
40	Leg Developer	1	91	Vertical Press Grip	2
41	Leg Developer Axle	1	92	Left Seat Support	1
42	Arm Curl Handle	1	93	108" Upper Cable	1
43	Arm Handle Sleeve	2	94	224" Front Press Cable	1
44	Arm Curl Handle tube	1	95	106" Butterfly Cable	1
45	Handle Grip	4	96	82" Leg Press Cable	1
46	Right Base Frame	1	97	Front Press Base	1
47	Lock Knob	1	98	M10 x 2" Allen Bolt	17
48	1" Square End Cap	4	99	M6 x 5/8" Philips Screw	1
49	Right Seat Support	1	100	M10 x 2 ½" Carriage Bolt	2
50	Rear Vertical Beam	1	101	Ankle Strap	1
51	Angled Double Floating Bracket	1	102	298" Vertical Press Cable	1

WEIGHT RESISTANCE CHART

	WEIGHT PLATE								
Station	1	2	3	4	5	6	7	8	9
Low Pulley	35	45	55	65	75	85	95	105	115
Lat Pull	20	30	40	50	60	70	80	90	100
Butterfly	10	17	24	31	38	45	52	59	66
Leg Press	20	30	40	50	60	70	80	90	100
Front Press	40	50	60	70	80	90	100	110	120
Vertical Press	20	30	35	40	45	50	60	70	80

	WEIGHT PLATE									
Station	10	11	12	13	14	15	16	17	18	19
Low Pulley	125	135	145	155	165	175	185	195	205	215
Lat Pull	110	120	130	140	150	160	170	180	190	200
Butterfly	73	80	87	94	101	108	115	122	129	136
Leg Press	110	120	130	140	150	160	170	180	190	200
Front Press	130	140	150	160	170	180	190	200	210	220
Vertical Press	90	100	110	120	130	140	150	160	170	180

*Numbers are approximate. Actual weight may vary.

*Value for butterfly is for each arm.

IMPEX INC.

LIMITED WARRANTY

IMPEX Inc. ("IMPEX") warrants this product to be free from defects in workmanship and material, under normal use and service conditions, for a period of two years on the Frame from the date of purchase. This warranty extends only to the original purchaser. IMPEX's obligation under this Warranty is limited to replacing or repairing, at IMPEX's option.

All returns must be pre-authorized by IMPEX. Pre-authorization may be obtained by calling IMPEX Customer Service Department at 1-800-999-8899. All freights on products returned to IMPEX must be prepaid by the customer. This warranty does not extend to any product or damage to a product caused by or attributable to freight damage, abuse, misuse, improper or abnormal usage or repairs not provided by an IMPEX authorized service center or for products used for commercial or rental purposes. No other warranty beyond that specifically set forth above is authorized by IMPEX.

IMPEX is not responsible or liable for indirect, special or consequential damages arising out of or in connection with the use or performance of the product or other damages with respect to any economic loss, loss of property, loss of revenues or profits, loss of enjoyments or use, costs of removal, installation or other consequential damages or whatsoever natures. Some states do not allow the exclusion or limitation of incidental or consequential damages. Accordingly, the above limitation may not apply to you.

The warranty extended hereunder is in lieu of any and all other warranties and any implied warranties of merchantability or fitness for a particular purpose is limited in its scope and duration to the terms set forth herein. Some states do not allow limitations on how long an implied warranty lasts. Accordingly, the above limitation may not apply to you.

This warranty gives you specific legal right. You may also have other rights which vary from state to state.

**IMPEX INC.
14777 Don Julian
City of Industry, CA 91746**

ORDERING REPLACEMENT PARTS

Replacement parts can be ordered by calling our Customer Service Department toll-free at **1-800-999-8899** during our regular business hours: Monday through Friday, 9 am until 5 pm Pacific standard time.

**www.impex-fitness.com
info@impex-fitness.com**

When ordering replacement parts, always give the following information.

1. Model
2. Description of Parts
3. Part Number
4. Date of Purchase

