

NOTE:
Please read all instructions
carefully before using this
product

Table of Contents

Safety Notice

Hardware Identifier

Assembly Instruction

Parts List

Warranty

Ordering Parts

Model
MD-PWR-20

Retain This
Manual for
Reference

08-19-08

OWNER'S
MANUAL

IMPEX

MARCY DIAMOND ELITE

OLYMPIC CAGE POWER-20

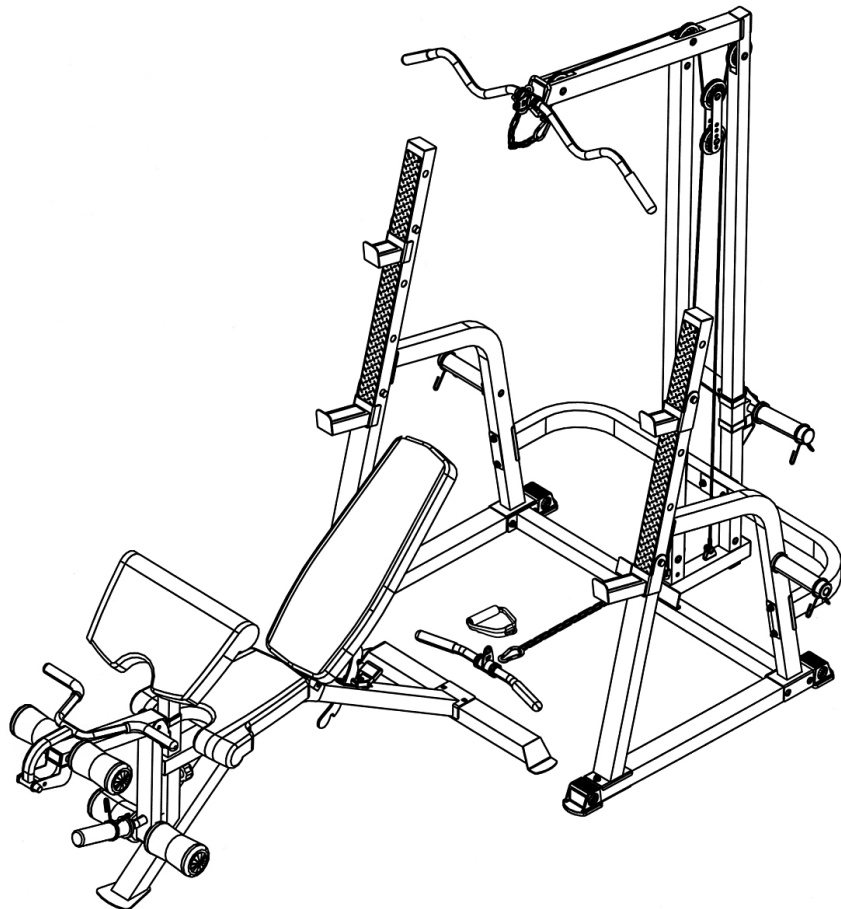

IMPEX® INC.

14777 DON JULIAN RD., CITY OF INDUSTRY, CA 91746

Tel: (800) 999-8899 Fax: (626) 961-9966

www.impex-fitness.com

info@impex-fitness.com

TABLE OF CONTENTS

BEFORE YOU BEGIN.....	1
IMPORTANT SAFETY NOTICES.....	2
HARDWARE PACK.....	4
ASSEMBLY INSTRUCTIONS.....	6
EXPLODED DIAGRAM.....	16
PARTS LIST.....	17
WARRANTY.....	18
ORDERING PARTS.....	18

BEFORE YOU BEGIN

Thank you for selecting the MARCY DIAMOND ELITE PWR-20 Olympic Cage by IMPEX[®] INC. For your safety and benefit, read this manual carefully before using the machine. As a manufacturer, we are committed to provide you complete customer satisfaction. If you have any questions, or find there are missing or damaged parts, we guarantee you complete satisfaction through direct assistance from our factory. To avoid unnecessary delays, *please call our TOLL-FREE customer service number.* Our Customer Service Agents will provide immediate assistance to you.

Toll-Free Customer Service Number

1-800-999-8899

Mon. - Fri. 9 a.m. - 5 p.m. PST

www.impex-fitness.com

info@impex-fitness.com

IMPORTANT SAFETY NOTICE

PRECAUTIONS

This exercise machine is built for optimum safety. However, certain precautions apply whenever you operate a piece of exercise equipment. Be sure to read the entire manual before you assemble or operate your machine. In particular, note the following safety precautions:

1. **Keep children and pets away from the machine at all times. DO NOT leave children unattended in the same room with the machine.**
2. Only one person at a time should use the machine.
3. If the user experiences dizziness, nausea, chest pain, or any other abnormal symptoms, STOP the workout at once. CONSULT A PHYSICIAN IMMEDIATELY.
4. Position the machine on a clear, leveled surface. DO NOT use the machine near water or outdoors.
5. Keep hands away from all moving parts.
6. Always wear appropriate workout clothing when exercising. DO NOT wear robes or other clothing that could become caught in the machine. Running or aerobic shoes are also required when using the machine.
7. Use the machine only for its intended use as described in this manual. DO NOT use attachments not recommended by the manufacturer.
8. Do not place any sharp object around the machine.
9. Disabled person should not use the machine without a qualified person or physician in attendance.
10. Before using the machine to exercise, always do stretching exercises to properly warm up.
11. Never operate the machine if the machine is not functioning properly.
12. A spotter is recommended during exercise.

CARE AND MAINTENANCE

1. Lubricate moving parts with WD-40 or light oil periodically.
2. Inspect and tighten all parts before using the machine.
3. The machine can be cleaned using a damp cloth and mild non-abrasive detergent. DO NOT use solvents.
4. Maximum user's weight: 300 lbs.
5. Maximum weights on the rack: 600 lbs.
6. Maximum weights on Leg Developer: 100 lbs.

WARNING: BEFORE BEGINNING ANY EXERCISE PROGRAM, CONSULT YOUR PHYSICIAN. THIS IS ESPECIALLY IMPORTANT FOR INDIVIDUALS OVER THE AGE OF 35 OR PERSONS WITH PRE-EXISTING HEALTH PROBLEMS. READ ALL INSTRUCTIONS BEFORE USING ANY FITNESS EQUIPMENT. IMPEX INC. ASSUMES NO RESPONSIBILITY FOR PERSONAL INJURY OR PROPERTY DAMAGE SUSTAINED BY OR THROUGH THE USE OF THIS PRODUCT.

SAVE THESE INSTRUCTIONS.

WARNING LABEL REPLACEMENT

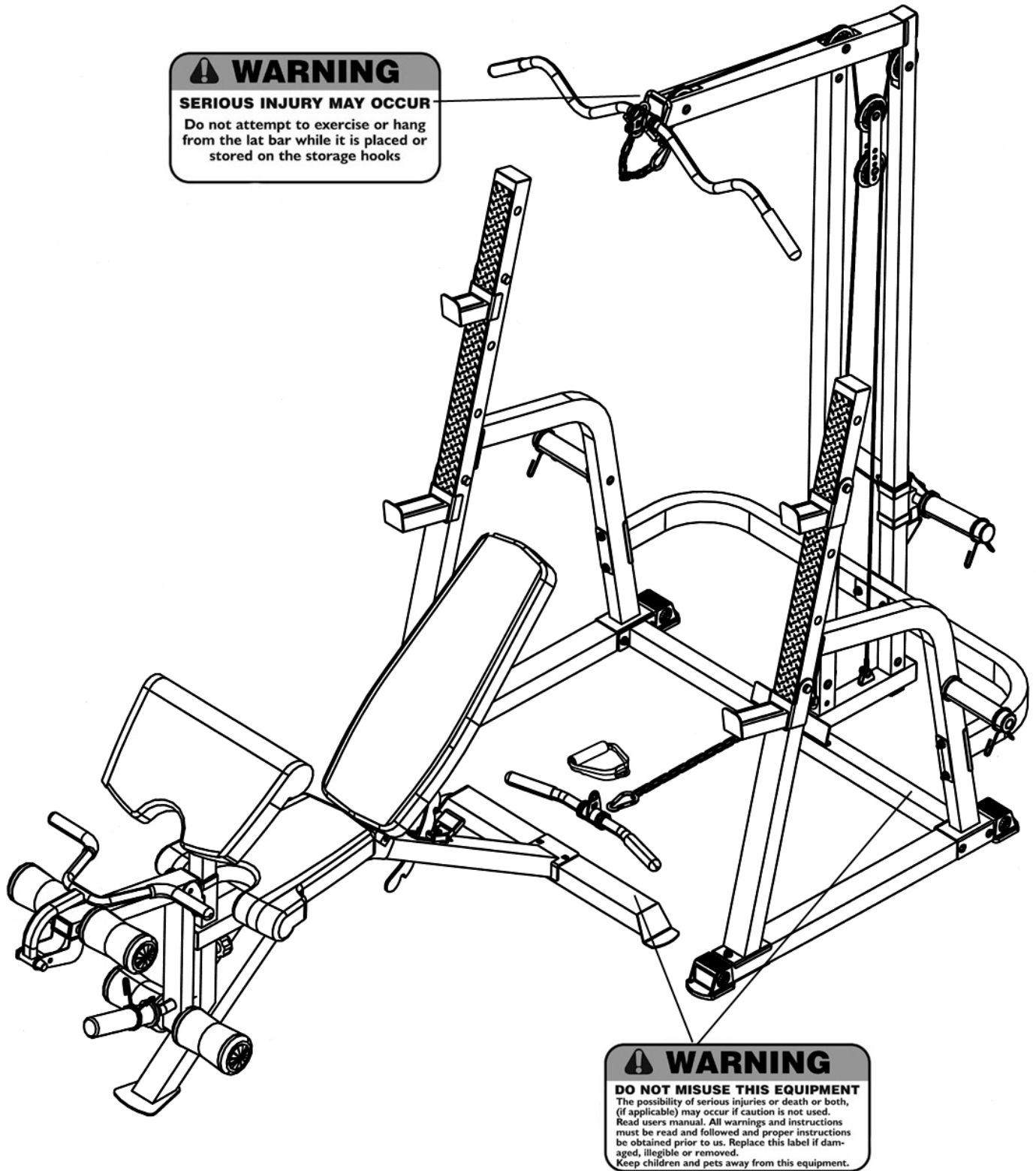

The warning labels shown here have been placed on the Rear Stabilizer, and Upper Frame. If the labels are missing or illegible, please call customer service at 1-800-888-8899 for replacements. Apply the labels in the location shown.

HARDWARE PACK

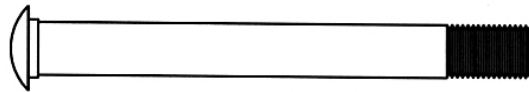

#68 M10 x 3 $\frac{3}{4}$ " Carriage Bolt (Qty 4)

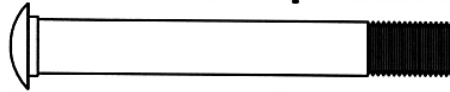

#69 M10 x 3 $\frac{1}{8}$ " Carriage Bolt (Qty 4)

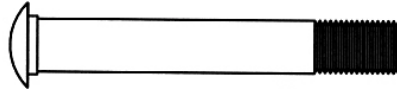

#70 M10 x 2 $\frac{3}{4}$ " Carriage Bolt (Qty 8)

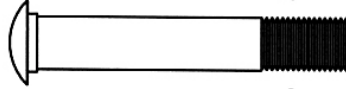

#71 M10 x 2 $\frac{3}{8}$ " Carriage Bolt (Qty 2)

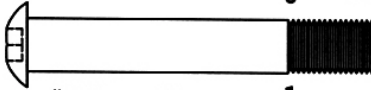

#75 M10 x 2 $\frac{1}{2}$ " Allen Bolt (Qty 3)

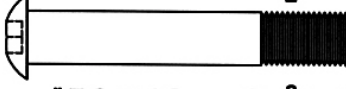

#76 M10 x 2 $\frac{3}{8}$ " Allen Bolt (Qty 3)

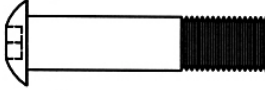

#77 M10 x 1 $\frac{3}{4}$ " Allen Bolt (Qty 2)



#78 M10 x 1" Allen Bolt (Qty 1)

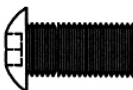

#79 M10 x $\frac{3}{4}$ " Allen Bolt (Qty 1)

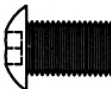

#80 M8 x $\frac{5}{8}$ " Allen Bolt (Qty 10)

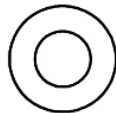

#84 \varnothing $\frac{3}{4}$ " Washer
(Qty 45)



#86 M10 Aircraft Nut
(Qty 29)

mm

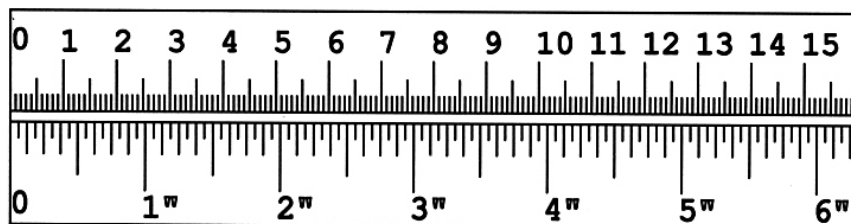

HARDWARE PACK

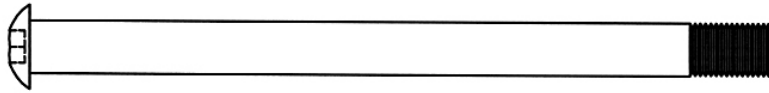

#72 M10 x 6 1/2" Allen Bolt (Qty 1)

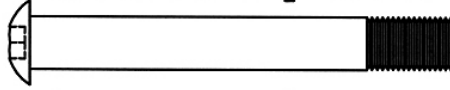

#73 M10 x 3 1/2" Allen Bolt (Qty 1)

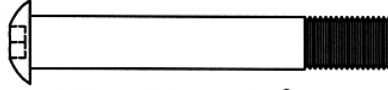

#74 M10 x 2 3/4" Allen Bolt (Qty 1)



#81 M8 x 1 5/8" Allen Bolt (Qty 12)



#82 M8 x 5/8" Allen Bolt (Qty 2)

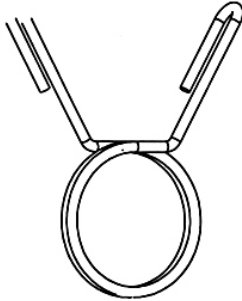

#44 Spring Clip (Qty 5)



#88 Hook (Qty 4)



#61 Ø 1" x 1/2" Pulley Bushing (Qty 2)



#89 Short Chain (Qty 1)



#62 Ø 1" x 5/8" Pulley Bushing (Qty 6)

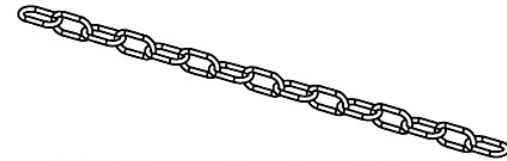

#90 Long Chain (Qty 1)



#87 M8 Aircraft Nut (Qty 4)



#85 Ø 5/8" Washer (Qty 18)

mm

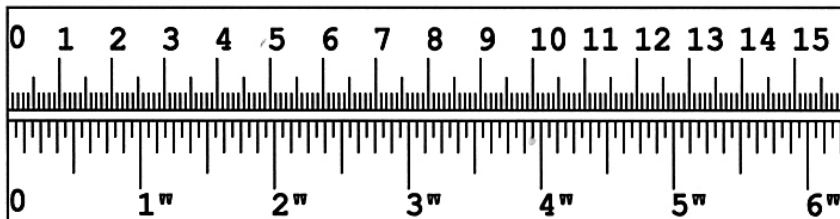

ASSEMBLY INSTRUCTION

Tools Required for Assembling the Machine: Two Adjustable Wrenches and Allen Wrenches. NOTE: It is strongly recommended that two or more people assemble this machine to avoid possible injury.

STEP 1 (See Diagram 1)

- A.) **Note: Do not tighten the Nuts and Bolts until instructed to do so.**
- B.) Attach an Upright Beam (#3) onto a Floor Stabilizer (#1). Secure it with two M10 x 2 3/4" Carriage Bolts (#70), two Ø 3/4" Washers (#84), and two M10 Aircraft Nuts (#86).
- C.) Attach the top of Left Support (#4) to the Upright Beam (#3). Secure it with two M10 x 5/8" Allen Bolts (#80) and two Ø 3/4" Washers (#84). Attach the Left Support onto the Floor Stabilizer.
- D.) Repeat Procedure B & C to install the other side.
- E.) Attach each end of the Rear Stabilizer (#7) to the bottom of Left & Right Support. Align the holes. Secure each end of Rear Stabilizer, Support, and Floor Stabilizer together with two M10 x 3 3/4" Carriage Bolts (#68), two Ø 3/4" Washers (#84), and two M10 Aircraft Nuts (#86).
- F.) Attach the Left & Right Safety Catch (#11 & #12), Left & Right Bar Catch (#13 & #14) onto the two Upright Beams.

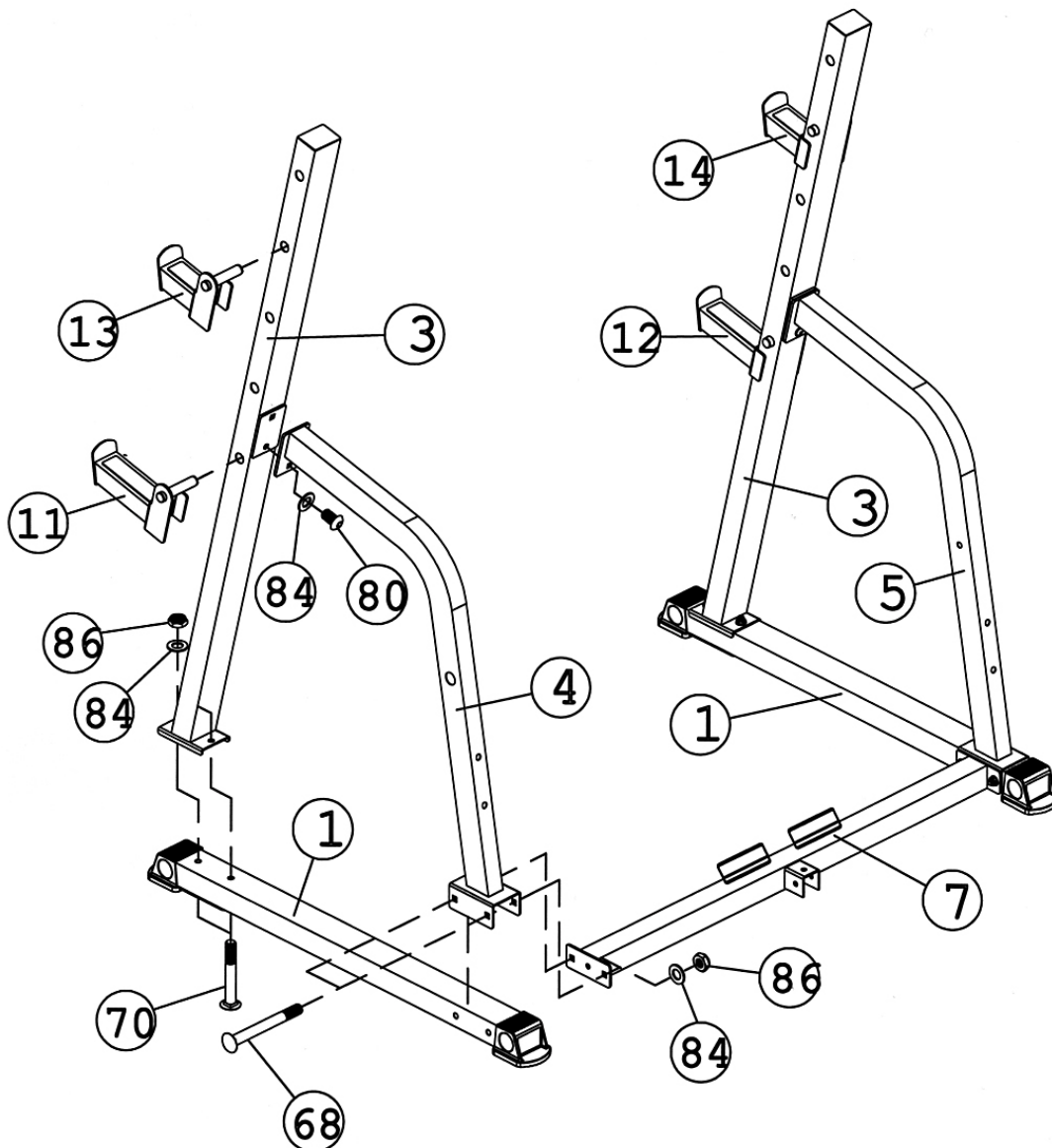

STEP 2 (See Diagram 2)

- A.) Attach the Front Vertical Frame (#8) to the bracket on Rear Stabilizer (#7).
Secure it with two M10 x 5/8" Allen Bolts (#80) and two Ø 3/4" Washers (#84).
- B.) Attach Cross Brace (#2) to the Left & Right Support (#4 & #5). Secure each of the Cross Brace with two M10 x 3 1/8" Carriage Bolts (#69), one 5 1/8" x 1 5/8" Brackets (#38), two Ø 3/4" Washers (#84), and two M10 Aircraft Nuts (#86).
- C.) Attach the Rear Vertical Frame (#6) onto the bracket on Front Vertical Frame.
Secure them with two M10 x 5/8" Allen Bolts (#80) and two Ø 3/4" Washers (#84).
- D.) Attach the Rear Vertical Frame (#6) to the Cross Brace. Secure them with two M10 x 2 3/8" Carriage Bolts (#71), one 4 3/8" x 2 3/8" Bracket (#39), two Ø 3/4" Washers (#84), and two M10 Aircraft Nuts (#86).
- E.) **Securely tighten all Nuts and Bolts installed in Step-1 and Step-2.**
- F.) Insert two Weight Posts (#21) into the holes on Left & Right Support. Secure each Weight Post with one M10 x 5/8" Allen Bolts (#80) and Ø 3/4" Washer.
- G.) Slide two Olympic Sleeves (#65) onto the Posts. Attach a Spring Clip (#44) onto each Sleeve.

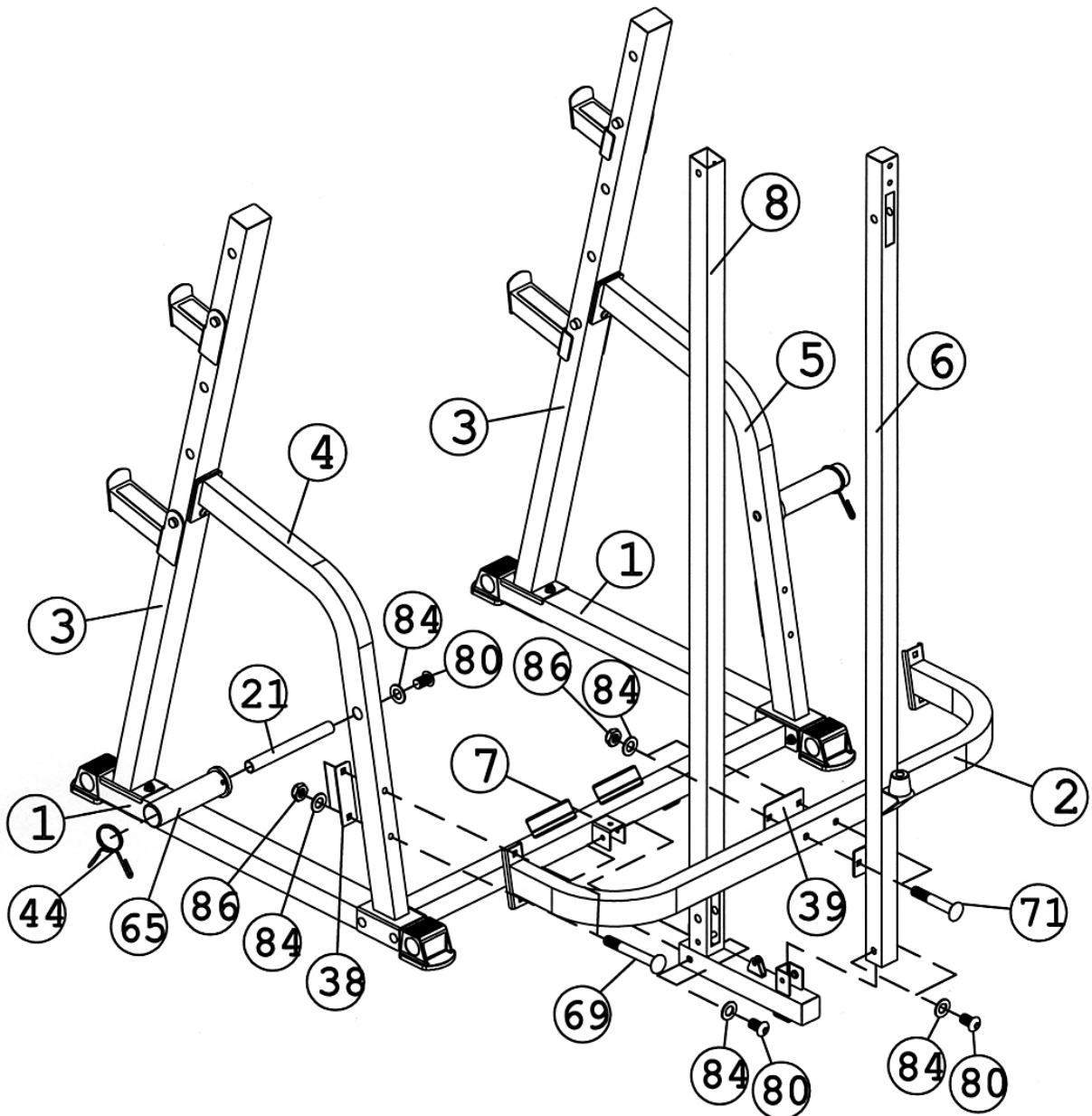

STEP 3 (See Diagram 3)

- A.) Slide the Sliding Weight Post (#10) onto the Rear Vertical Frame (#6) from top. **Make sure the triangular cable connecting bracket faces up.**
- B.) Insert the open bracket on the Upper Frame (#9) into top of the Front Vertical Frame (#8). Secure them with two M10 x 5/8" Allen Bolts (#80), and two Ø 3/4" Washers (#84). **Do not tighten the Bolts yet.**
- C.) Attach the rear of Upper Frame to the Rear Vertical Frame. Secure them together with two M10 x 2 3/8" Allen Bolts (#76) and two Ø 3/4" Washers (#84). **Securely tighten all Bolts in Procedure B & C.**
- D.) Slide two Olympic Sleeves (#65) onto the posts on Sliding Weight Post. Attach a Spring Clip (#44) onto each Sleeve.

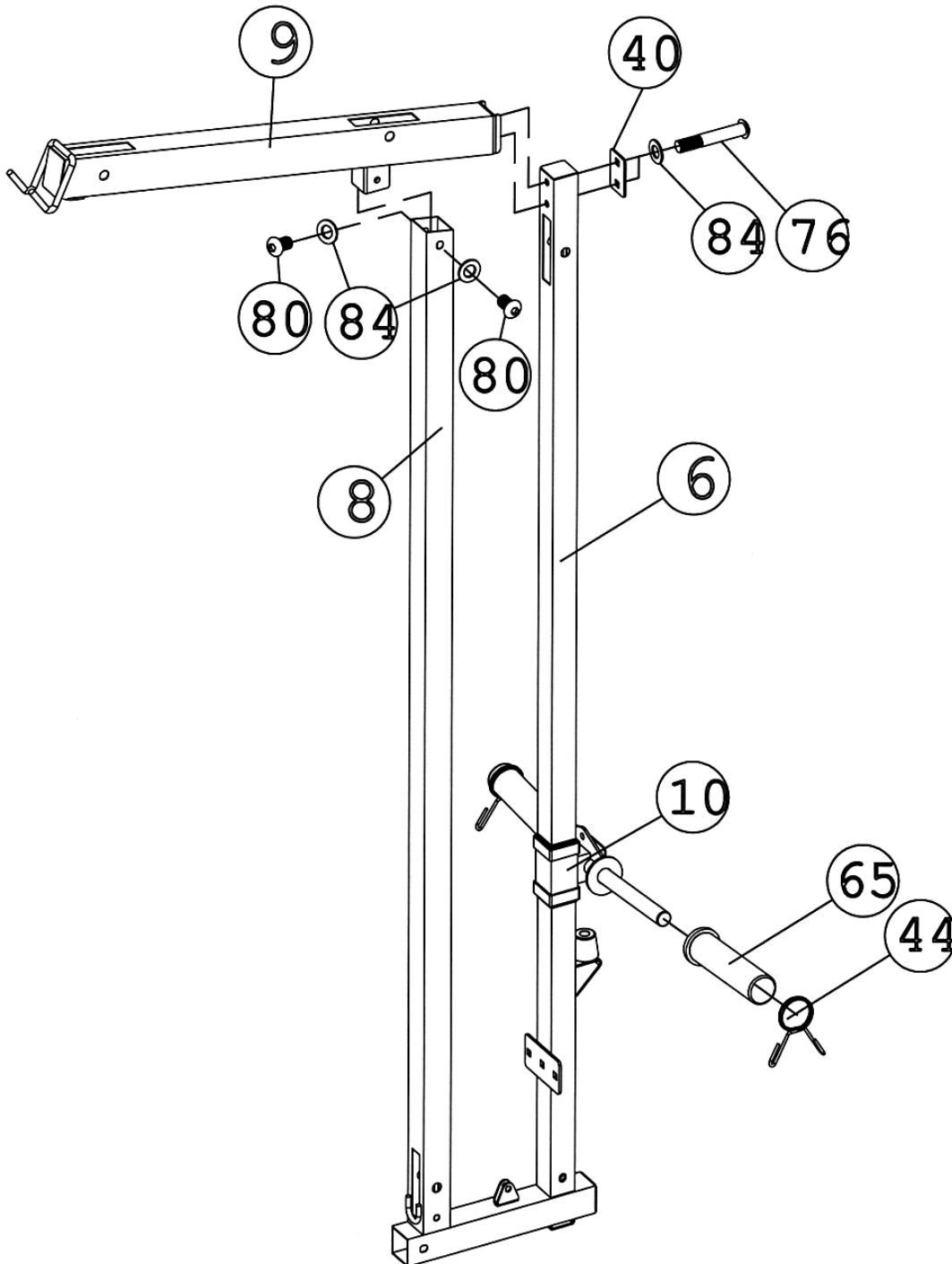

STEP 4 (See Diagram 4)

- A.) Attach the 100" Upper Cable (#42) to the opening on the front of Upper Frame (#9). Attach a Pulley (#57) to the opening. Secure it with one M10 x 2 ½" Allen Bolt (#75), two Ø 1" x 5/8" Pulley Bushings (#62), and one M10 Aircraft Nut (#86). **Note: The ball stopper of the Cable must be underneath the Frame.**
- B.) Draw the cable over the Pulley along the Upper Frame toward back to the other opening on the Upper Frame.
- C.) Attach a Pulley to the opening. Secure it with one M10 x M10 x 2 ½" Allen Bolt (#75), two Ø 1" x ½" Pulley Bushings (#61), and one M10 Aircraft Nut (#86).
- D.) Draw the Cable around the Pulley then downward. Attach a Pulley to the top holes on the two Double Floating Pulley Brackets (#41). Secure the Pulley with one M10 x 1 ¾" Allen Bolt (#77), two Ø ¾" Washers (#84), and one M10 Aircraft Nut (#86).
- E.) Draw the Cable around the Pulley then upward to the opening on the Rear Vertical Frame (#6). Attach a Pulley to the opening. Secure it with one M10 x 2 3/8" Allen Bolt (#76), two Ø 1" x ½" Pulley Bushings (#61), and one M10 Aircraft Nut (#86).
- F.) Draw the Cable around the Pulley then down to the bracket on the Sliding Weight Post (#10). Secure the Cable with one M10 x ¾" Allen Bolt (#79) and one Ø ¾" Washer (#84).
- G.) Attach the 123" Lower Cable (#43) to the opening on the bottom of Front Vertical Frame (#8). Attach a Pulley to the opening. Secure it with one M10 x 2 ½" Allen Bolt (#75), two Ø 1" x 5/8" Pulley Bushings (#62), and one M10 Aircraft Nut (#86).
- H.) Draw the Cable around the Pulley then upward to the Double Floating Pulley Brackets. Attach a Pulley to the Brackets. Secure it with one M10 x 1 ¾" Allen Bolt (#77), two Ø ¾" Washers (#84), and one M10 Aircraft Nut (#86).
- I.) Draw the Cable around the Pulley then down to the open bracket on the base of Rear Vertical Frame. Secure the Cable to the bracket with one M10 x 1" Allen Bolt (#78), two Ø ¾" Washers (#84), and one M10 Aircraft Nut (#86).
- J.) Adjust the tension of the Cable system by adjusting the Pulley position on the Double Floating Pulley Brackets. If the Cable is too loose, move up the Pulley one hole. If the cable is too tight, move down the Pulley one hole.
- K.) Connect the Lat Bar (#15) to the Upper Cable with two Hooks (#88) and one Short Chain (#89).
- L.) Connect the Shiver Bar (#16) to the Lower Cable with two Hooks (#88) and one Short Chain (#89).
- M.) Replace the Shiver Bar by Ankle Strap (#92) for various exercises.

DIAGRAM 4

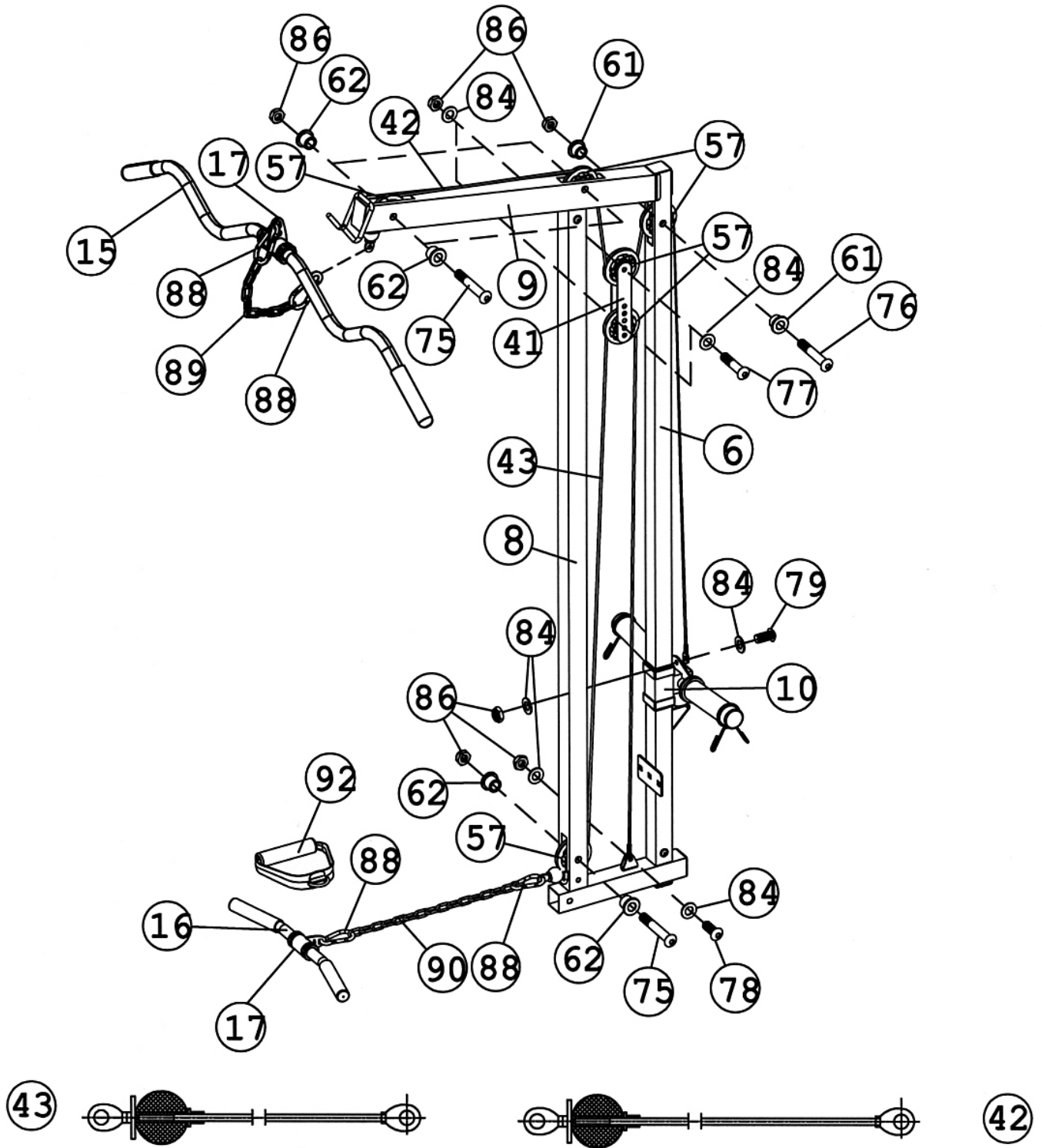

STEP 5 (See Diagram 5)

- A.) **Do not tighten the Nuts and Bolts until instructed to do so.**
- B.) Attach the Main Seat Support (#18) onto the Front Post (#22). Attach the Seat Bracket (#24) onto the Main Seat Support. Align the holes. Secure the Seat Bracket, Main Seat Support, and Front Post together with two M10 x 2 3/4" Carriage Bolts (#70), two Ø 3/4" Washers (#84), and two M10 Aircraft Nuts (#86).
- C.) Secure the Main Seat Support to the Front Post with one M10 x 2 3/4" Allen Bolt (#74) and Ø 3/4" Washer (#84).
- D.) Attach the Main Seat Support to the Bench Rear Stabilizer (#23). Secure it with two M10 x 2 3/4" Carriage Bolts (#70), one 4 3/8" x 1 3/4" Bracket (#37), two Ø 3/4" Washers (#84), and two M10 Aircraft Nuts (#86).
- E.) **Securely tighten all Nuts and Bolts installed.**

DIAGRAM 5

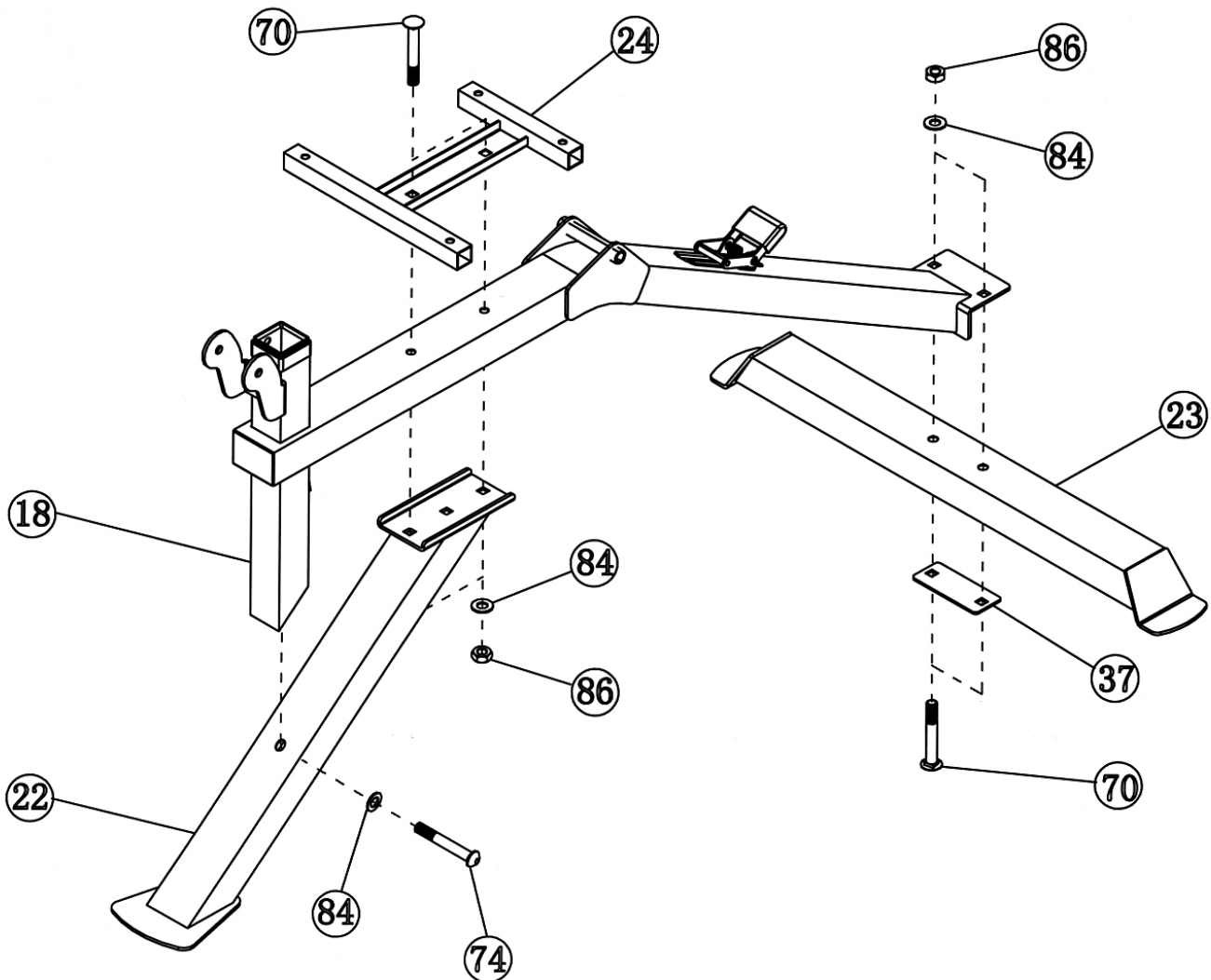

STEP 6 (See Diagram 6)

A.) **Do not tighten Nuts and Bolts until instructed to do so.**

B.) Align the bracket on the Backrest Adjustment Support (#32) in between the two Backrest Supports (#35). Secure it with four M8 x 1 5/8" Allen Bolts (#81), eight Ø 5/8" Washers (#85), and four M8 Aircraft Nuts (#87).

C.) Insert the Backrest Adjustment Support into the opening on the Main Seat Support (#18). Press or step down on the Backrest Adjustment Lever (#36) to allow the Support to go through.

D.) Attach the bottom side-holes on the two Backrest Support to the pivot on the Main Seat Support. Secure it with one M10 x 6 1/2" Allen Bolt (#72), two Ø 3/4" Washers (#84), and one M10 Aircraft Nut (#86).

E.) Attach the Backrest Board (#29) to the Backrest Supports. Secure it with four M8 x 1 5/8" Allen Bolts (#81) and Ø 5/8" Washers (#85).

F.) Attach the Seat Pad (#30) to Seat Bracket (#24). Secure it with four M8 x 1 5/8" Allen Bolts (#81) and Ø 5/8" Washers (#85).

G.) **Securely tighten all Nuts and Bolts.**

H.) When adjusting the Backrest Board to an incline position, simply pull up the Board. When adjusting the Board to a decline position, press or step down on the Backrest Adjustment Lever to disengage the Lever to allow the Board to go down.

DIAGRAM 6

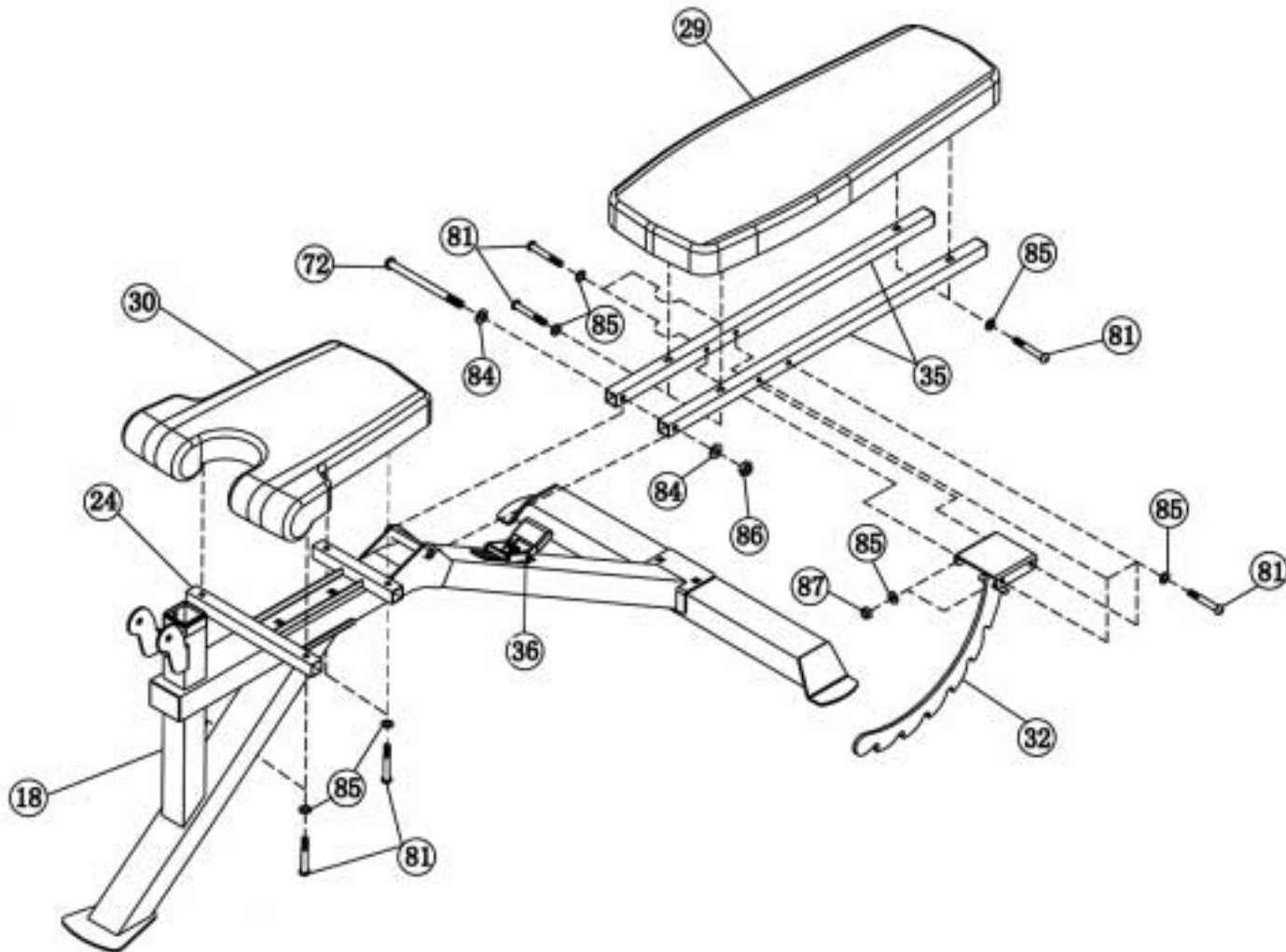

STEP 7 (See Diagram 7)

- A.) Attach the Leg Developer (#25) to the open bracket on the Main Seat Support (#18). Secure it with one M10 x 3 1/2" Allen Bolt (#73), two Ø 3/4" Washers (#84), and one M10 Aircraft Nut (#86). **Note: Do not over tighten the Nut and Bolt. Make sure the Leg Developer is able to move smoothly.**
- B.) Insert two Foam Tubes (#26) halfway through the holes on Leg Developer. Push four Foam Rolls (#58) onto the Tubes from each end. Plug four Foam Roll End Caps (#55) into the Ends.
- C.) Slide an Olympic Sleeve (#65) onto the weight post on Leg Developer. Attach a Spring Clip (#44) to the Sleeve.
- D.) Attach the Arm Curl Handle (#27) to the bracket on the Leg Developer. Secure it in position with a Lock Pin (#64).

DIAGRAM 7

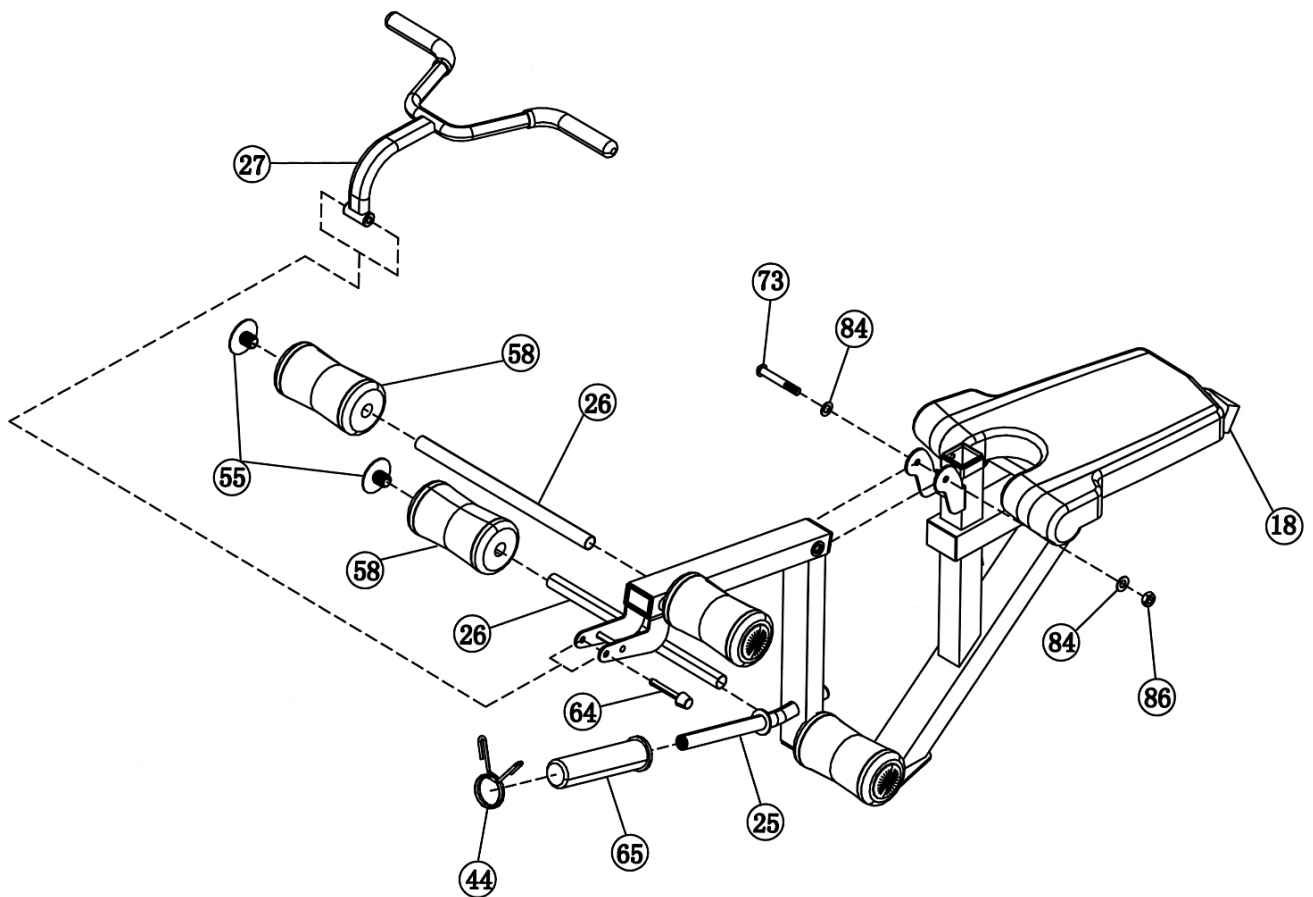

STEP 8 (See Diagram 8)

- A.) Attach the Arm Curl Pad (#31) to the Arm Curl Stand (#28). Secure it with two M8 x 5/8" Allen Bolts (#82) and two Ø 5/8" Washers (#85).
- B.) Insert the Arm Curl Stand into the opening on the Main Seat Support (#18). Use the Lock Knob (#63) to lock the Stand at desired height.
- C.) Remove Arm Curl Stand and Arm Curl Hand when doing Leg Developer exercises.

DIAGRAM 8

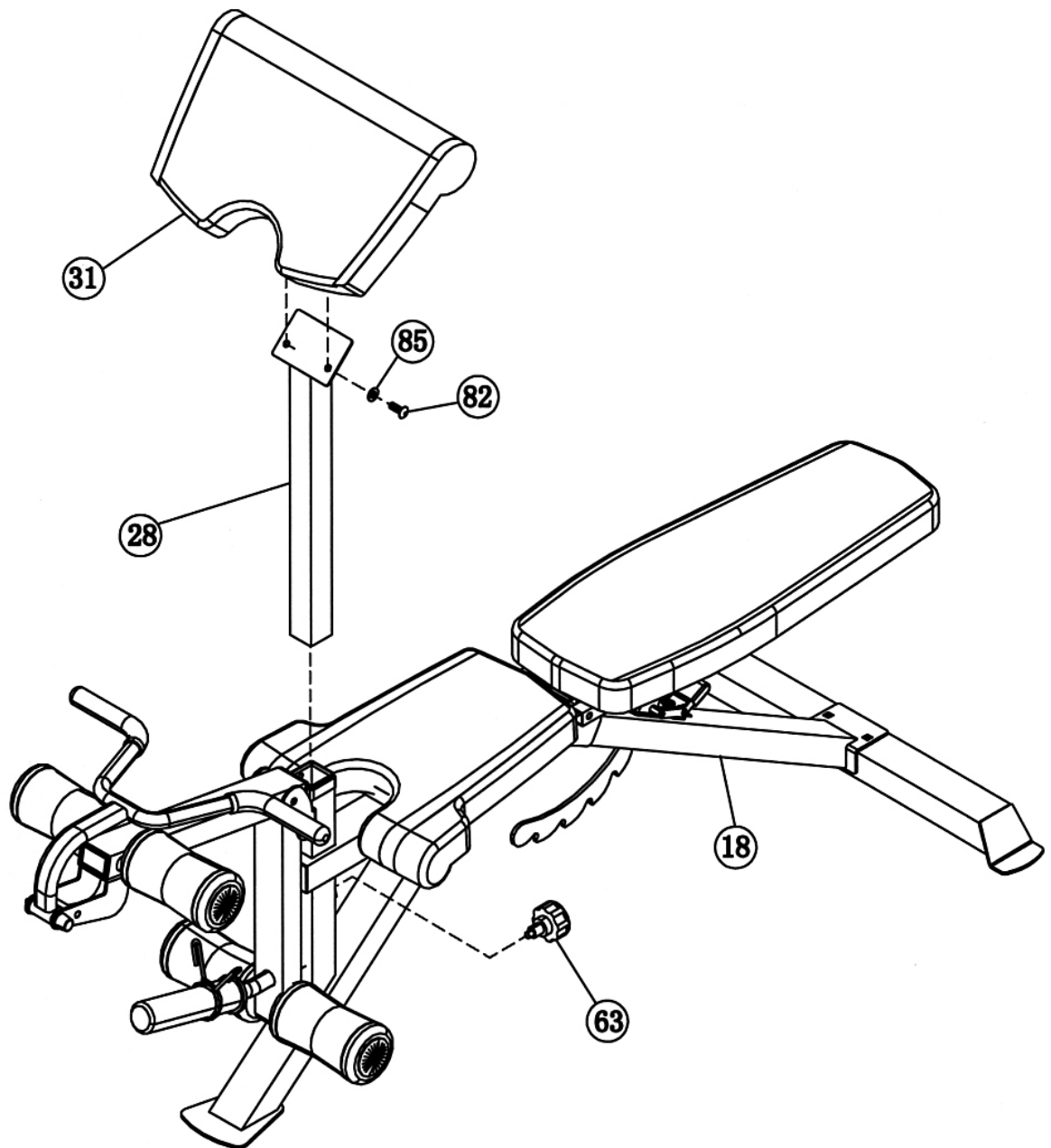

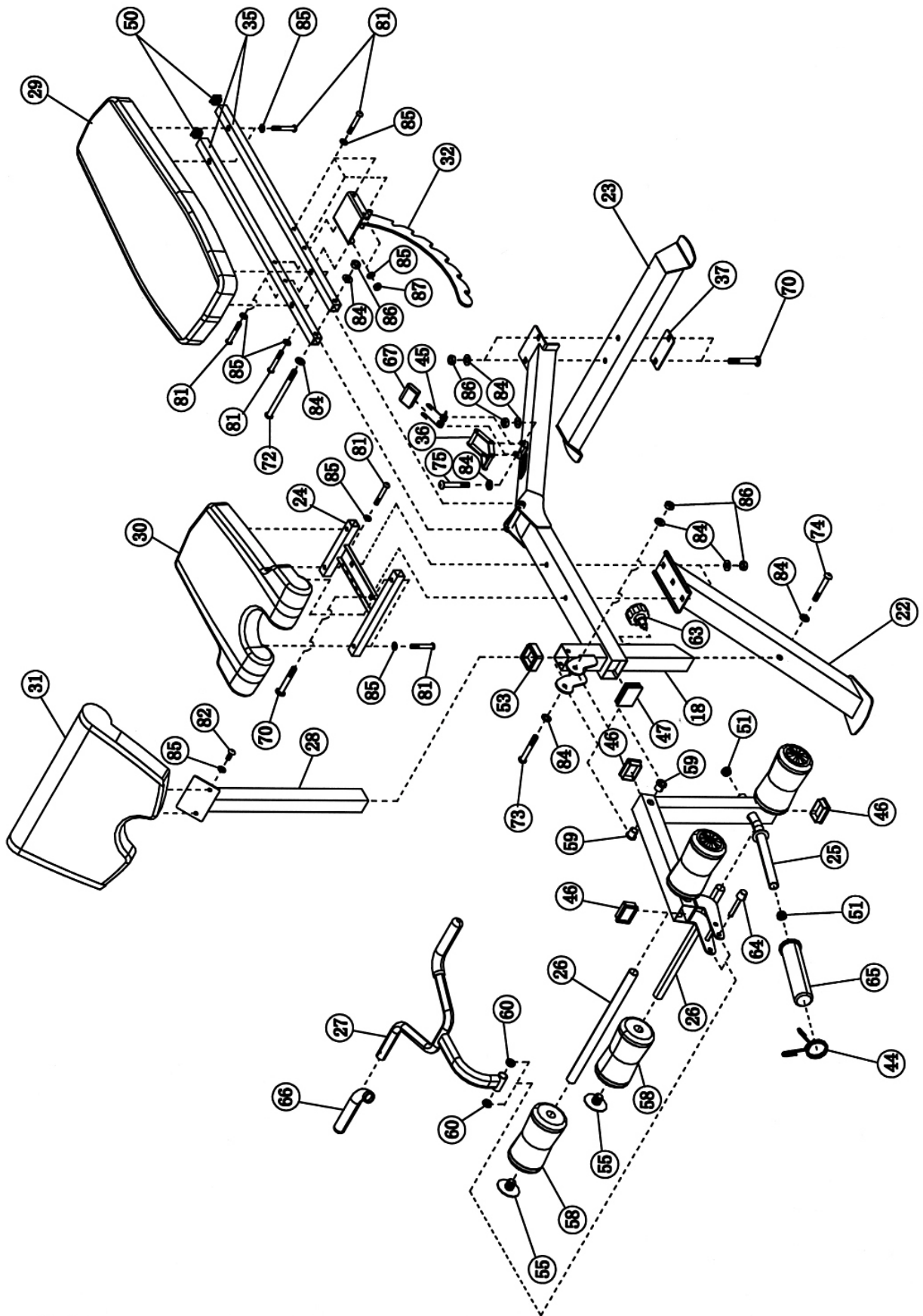

BENCH EXPLODED DIAGRAM

PARTS LIST

KEY NO.	DESCRIPTION	Q'ty			
1	Floor Stabilizer	2	51	Ø 1" End Cap	6
2	Cross Brace	1	52	Ø ¾" End Cap	8
3	Upright Beam	2	53	2" Sleeve	3
4	Left Support	1	54	Ø 1 ¾" Rubber Bumper	1
5	Right Support	1	55	Foam Roll End Cap	4
6	Rear Vertical Frame	1	56	2 ¾" Floor Stabilizer End Cap	4
7	Rear Stabilizer	1	57	Pulley	6
8	Front Vertical Frame	1	58	Foam Roll	4
9	Upper Frame	1	59	Leg Developer Bushing	2
10	Sliding Weight Post	1	60	Ø 1" Arm Curl Handle Bushing	2
11	Left Safety Catch	1	61	Ø 1" x ½" Pulley Bushing	2
12	Right Safety Catch	1	62	Ø 1" x 5/8" Pulley Bushing	6
13	Left Bar Catch	1	63	Lock Knob	1
14	Right Bar Catch	1	64	Lock Pin	1
15	Lat Bar	1	65	Olympic Sleeve	5
16	Shiver Bar	1	66	Handle Grip	6
17	Rotate Connector	2	67	Lever Cover	1
18	Main Seat Support	1	68	M10 x 3 ¾" Carriage Bolt	4
19	Plastic Ring	8	69	M10 x 3 1/8" Carriage Bolt	4
20	Panel	2	70	M10 x 2 ¾" Carriage Bolt	8
21	Weight Post	2	71	M10 x 2 3/8" Carriage Bolt	2
22	Front Post	1	72	M10 x 6 ½" Allen Bolt	1
23	Bench Rear Stabilizer	1	73	M10 x 3 ½" Allen Bolt	1
24	Seat Bracket	1	74	M10 x 2 ¾" Allen Bolt	1
25	Leg Developer	1	75	M10 x 2 ½" Allen Bolt	4
26	Foam Tube	2	76	M10 x 2 3/8" Allen Bolt	3
27	Arm Curl Handle	1	77	M10 x 1 ¾" Allen Bolt	2
28	Arm Curl Stand	1	78	M10 x 1" Allen Bolt	1
29	Backrest Board	1	79	M10 x ¾" Allen Bolt	1
30	Seat Pad	1	80	M10 x 5/8" Allen Bolt	10
31	Arm Curl Pad	1	81	M8 x 1 5/8" Allen Bolt	12
32	Backrest Adjustment Support	1	82	M8 x 5/8" Allen Bolt	2
33	2 1/8" x 5 ¾" Rubber Bumper	2	83	M6 x 5/8" Philips Screw	1
34	2 1/8" x 3 3/8" Rubber Bumper	2	84	Ø ¾" Washer	45
35	Backrest Support	2	85	Ø 5/8" Washer	18
36	Backrest Adjustment Lever	1	86	M10 Aircraft Nut	29
37	4 3/8" x 1 ¾" Bracket	1	87	M8 Aircraft Nut	4
38	5 1/8" x 1 5/8" Bracket	2	88	Hook	4
39	4 3/8" x 2 3/8" Bracket	1	89	Short Chain	1
40	2 ¾" x 1 ¾" Bracket	1	90	Long Chain	1
41	Double Floating Pulley Bracket	2	91	Rivet	24
42	100" Upper Cable	1	92	Ankle Strap	1
43	123" Lower Cable	1		#4 Allen Wrench (Tool)	1
44	Spring Clip	5		#5 Allen Wrench (Tool)	1
45	Lever Spring	1		#6 Allen Wrench (Tool)	1
46	2 3/8" x 1 5/8" End Cap	3			
47	2 ¾" x 2" End Cap	4			
48	1 ¾" Square End Cap	1			
49	2" Square End Cap	2			
50	1" Square End Cap	2			

IMPEX[®] INC.

LIMITED WARRANTY

IMPEX Inc. ("IMPEX[®]") warrants this product to be free from defects in workmanship and material, under normal use and service conditions, for a period of two years on the Frame from the date of purchase. This warranty extends only to the original purchaser. IMPEX's obligation under this Warranty is limited to replacing or repairing, at IMPEX's option.

All returns must be pre-authorized by IMPEX. Pre-authorization may be obtained by calling IMPEX Customer Service Department at 1-800-999-8899. All freights on products returned to IMPEX must be prepaid by the customer. This warranty does not extend to any product or damage to a product caused by or attributable to freight damage, abuse, misuse, improper or abnormal usage or repairs not provided by an IMPEX authorized service center or for products used for commercial or rental purposes. No other warranty beyond that specifically set forth above is authorized by IMPEX.

IMPEX is not responsible or liable for indirect, special or consequential damages arising out of or in connection with the use or performance of the product or other damages with respect to any economic loss, loss of property, loss of revenues or profits, loss of enjoyments or use, costs of removal, installation or other consequential damages or whatsoever natures. Some states do not allow the exclusion or limitation of incidental or consequential damages. Accordingly, the above limitation may not apply to you.

The warranty extended hereunder is in lieu of any and all other warranties and any implied warranties of merchantability or fitness for a particular purpose is limited in its scope and duration to the terms set forth herein. Some states do not allow limitations on how long an implied warranty lasts. Accordingly, the above limitation may not apply to you.

This warranty gives you specific legal right. You may also have other rights which vary from state to state. Register on-line at www.impex-fitness.com

IMPEX[®] INC.
14777 Don Julian
City of Industry, CA 91746

ORDERING REPLACEMENT PARTS

Replacement parts can be ordered by calling our Customer Service Department toll-free at **1-800-999-8899** during our regular business hours: Monday through Friday, 9 am until 5 pm Pacific standard time.
info@impex-fitness.com

When ordering replacement parts, always give the following information.

1. Model
2. Description of Parts
3. Part Number
4. Date of Purchase