

NOTE:
Please read all
instructions carefully
before using this product

Table of Contents

Safety Notice

Important Assembly
Information

Care and Maintenance

Parts List

Warranty

Ordering Parts

Model
ME-1016U

Retain This
Manual for
Reference

180501

**OWNER'S
MANUAL**

MARCY®

MAGNETIC UPRIGHT BIKE ME-1016U

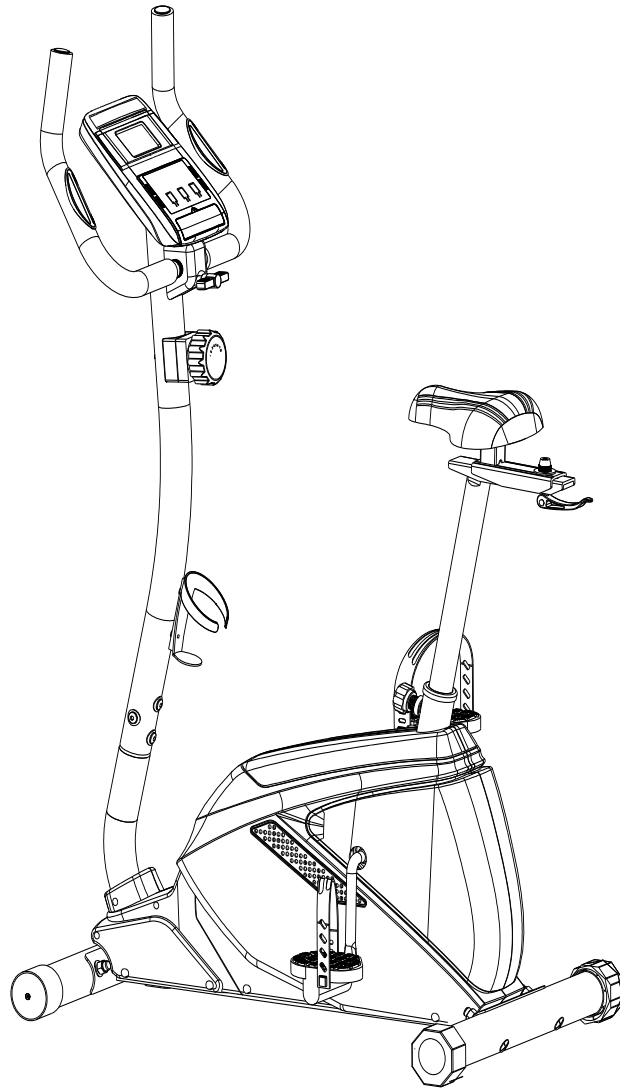

IMPORTANT: Please read this manual before commencing
assembly of this product.

IMPEX® INC.

2801 S. Towne Ave, Pomona, CA 91766

Tel: 800- 999-8899

www.marcypro.com

support@impex-fitness.com

TABLE OF CONTENTS

BEFORE YOU BEGIN	1
IMPORTANT SAFETY NOTICES	2
CARE AND MAINTENANCE	2
WARNING LABEL PLACEMENT	3
HARDWARE PACK	4
COMPONENTS	5
ASSEMBLY INSTRUCTIONS	6
EXPLODED DIAGRAM	12
PARTS LIST	14
COMPUTER INSTRUCTIONS	15
EXERCISE GUIDELINES	16
WARRANTY	18
ORDERING PARTS	18

BEFORE YOU BEGIN

Thank you for selecting MARCY MAGNETIC UPRIGHT BIKE ME-1016U by IMPEX® INC. For your safety and benefit, read this manual carefully before using the equipment. As a manufacturer, we are committed to providing you with complete customer satisfaction. If you have any questions, or find there are missing or damaged parts, we guarantee you complete satisfaction through direct assistance from our factory. To avoid unnecessary delays, *please call our TOLL-FREE customer service number*. Our Customer Service Agents will provide immediate assistance.

Toll-Free Customer Service Number

1-800-999-8899

Mon. – Fri. 9 a.m. – 5 p.m. PST

www.marcypro.com

support@impex-fitness.com

IMPORTANT SAFETY NOTICE

This exercise equipment is built for optimum safety. However, certain precautions apply whenever you operate a piece of exercise equipment. Be sure to read the entire manual before you assemble or operate your equipment. In particular, note the following safety precautions:

1. **Read the warning notice and instruction prior to assembling and using the equipment.**
2. **This equipment is not intended for children under 12 years of age.**
3. **This equipment can be only used by hands or feet. Do not stand with full weight on the pedals.**
4. Do not leave children unattended with the equipment.
5. **This equipment is intended for indoor use and for consumer use only.**
6. Position the equipment on a clear, leveled surface. Make sure the surface is free of objects that may cause tipping. Keep objects which could interfere with the user away.
7. Inspect before use. Keep frame padding in place. Never use the equipment if it is not functioning properly.
8. Always wear appropriate workout clothing when exercising.
9. Do not use the equipment when it is wet.
10. Use the equipment only with mature, knowledgeable supervision.
11. Do not use the equipment while under influence of alcohol or drugs.
12. While keeping the head erect, focus eyes on the equipment toward the perimeter.
13. Before exercising, always do stretching exercises to properly warm up.
14. If the user experience dizziness, nausea, chest pain, or any other abnormal symptoms, STOP the workout at once. CONSULT A PHYSICIAN IMMEDIATELY.

Care and Maintenance

1. For equipment information, contact the manufacturer.
2. Periodically inspect all parts to ensure all parts are functioning properly.
3. Replace any worn and/or damaged parts immediately.
4. Always keep the top surface of the pedals clean and dry.
5. Use mild household spray cleaners and/or a damp rag to wipe clean. Do not use harsh cleaning chemicals.
6. Sand rusted areas on tubular members and repaint using a non-lead-based paint meeting the requirements of Title 16 CFR Part 1303.
7. Disposal Instructions – The equipment can be safely disassembled and disposed.. Call your local recycle agency regarding details of recycling.
8. Assembled dimensions: 33"x19.5"x52"
9. Maximum User Weight Capacity: 250 lbs.

WARNING: BEFORE BEGINNING ANY EXERCISE PROGRAM, CONSULT YOUR PHYSICIAN. THIS IS ESPECIALLY IMPORTANT FOR INDIVIDUALS OVER THE AGE OF 35 OR PERSONS WITH PRE-EXISTING HEALTH PROBLEMS. READ ALL INSTRUCTIONS BEFORE USING ANY FITNESS EQUIPMENT. IMPEX INC. ASSUMES NO RESPONSIBILITY FOR PERSONAL INJURY OR PROPERTY DAMAGE SUSTAINED THROUGH THE USE OF THIS PRODUCT. SAVE THESE INSTRUCTIONS.

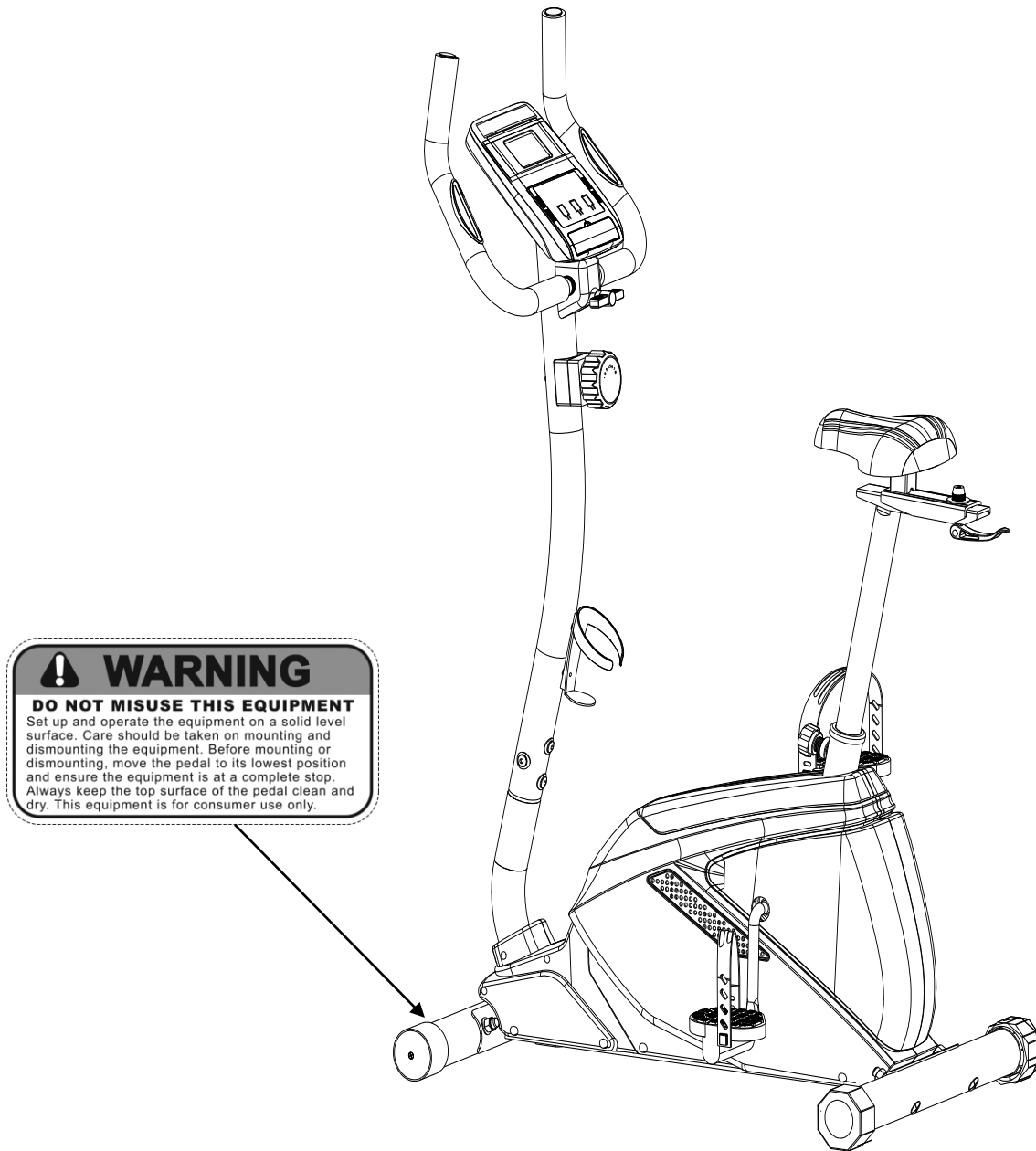

WARNING LABEL PLACEMENT



The warning labels shown here have been placed on the Base Frame. If the labels are missing or illegible, please call customer service at 1-800-999-8899 for replacements. Apply the labels in the location shown.

HARDWARE PACK

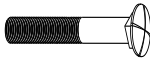
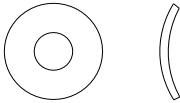
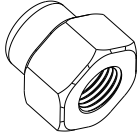
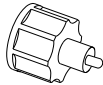
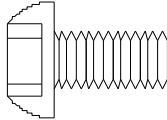
NOTE: The following parts are not drawn to scale. Please use your own ruler to measure the size.

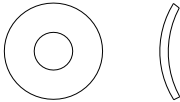
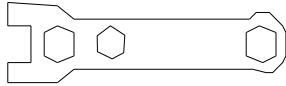
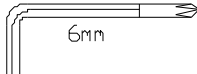
No.	Description	DRAWING	Q'ty
6	Carriage Bolt M10x3"		4
7	Curved Washer $\Phi\frac{3}{8}$ "		4
8	Domed Nut		4
11	Quick Release Knob		1
17	Allen Bolt M8x $\frac{5}{8}$ "		4
27	Decorative Cover		1
28	T-type Knob		1
42	Curved Washer $\Phi\frac{1}{3}$ "		4
	Box Wrench		1
	Allen key L6		1

COMPONENTS FOR ASSEMBLY

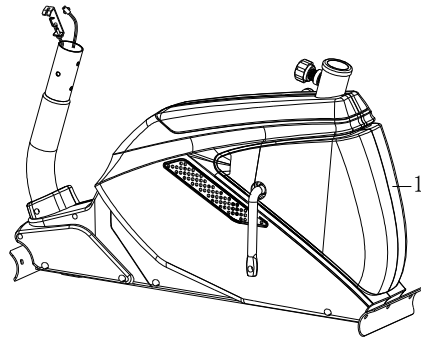

NO. 1

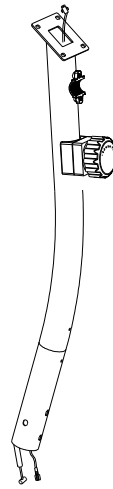

NO. 22

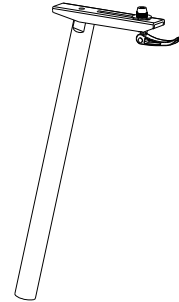

NO. 15



NO. 9



NO. 10



NO. 18

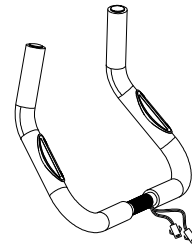

NO. 19

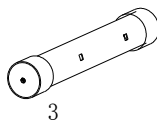

NO. 3

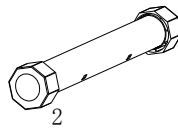

NO. 2



NO. 41



NO. 16

PART NO.	DESCRIPTION	Q'TY
1	Main frame	1
22	Front support	1
15	Seat support	1
18	Meter	1
9/10	Pedal (L/R)	1/1
16	Seat	1
19	Handlebar	1
3	Front stabilizer	1
2	Rear stabilizer	1
41	Bottle holder	1

ASSEMBLY INSTRUCTION

STEP 1

1. Attach the front stabilizer (#3) to the main frame (#1), Secure using two carriage bolts (#6), two curved washers (#7), two domed nuts (#8).
2. Attach the rear stabilizer (#2) to the main frame (#1), Secure using two carriage bolts (#6), two curved washers (#7), two domed nuts (#8)

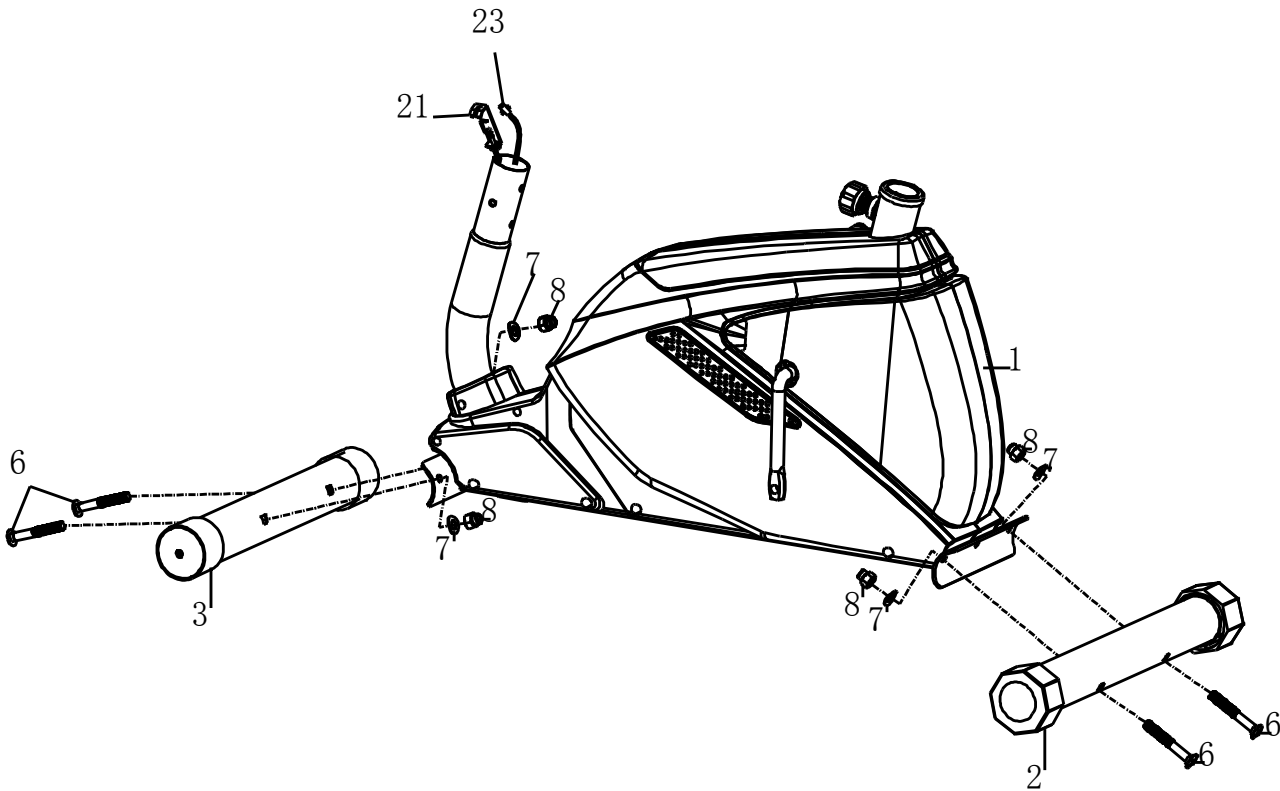

STEP 2

1. Take front post (#22) and connect the middle sensor wire (#24) to the lower sensor wire (#23). Adjust the tension control knob (#20) to level 8, then connect it to the lower tension cable (21).
2. Insert front post (#22) into main frame (#1) and tighten with 4 sets of Allen bolts (#17) and curved washers (#42).

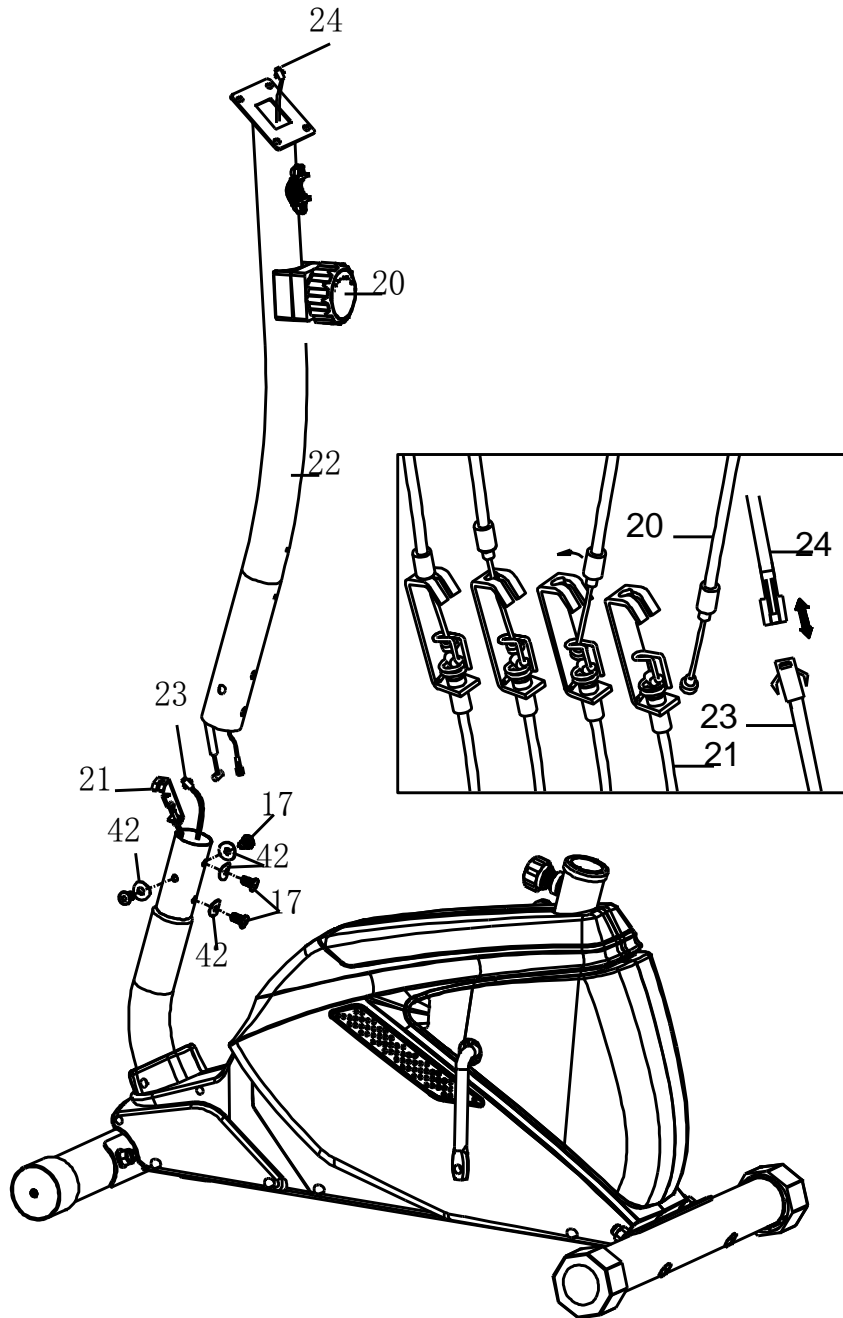

HOW TO CONNECT TENSION CONNECTOR

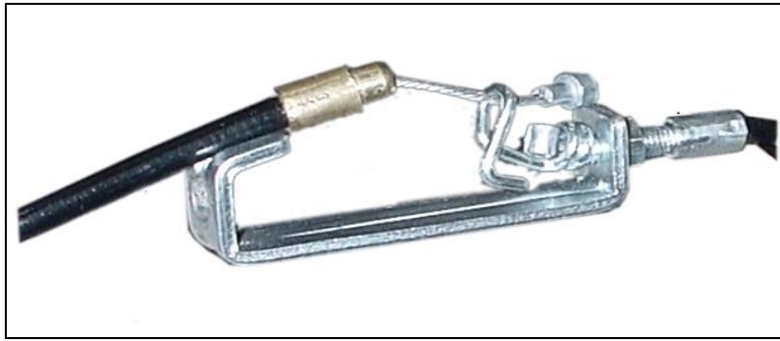

Slide the Cable wire from the extension sensor wire Connector in between the opening on the wire holder on sensor wire Connector.

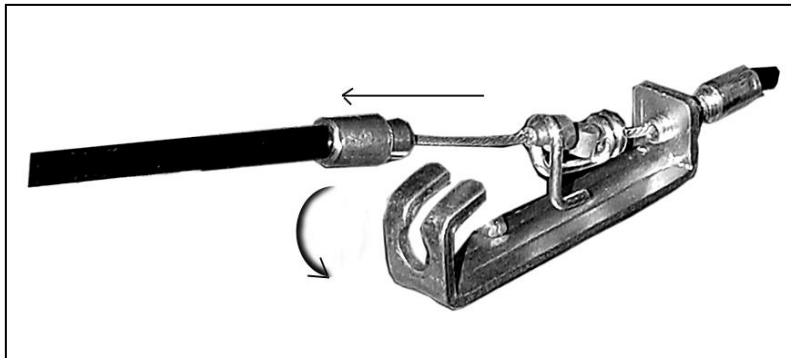

Pull the extension sensor wire Connector backward and slide the wire through the slot on the bracket.

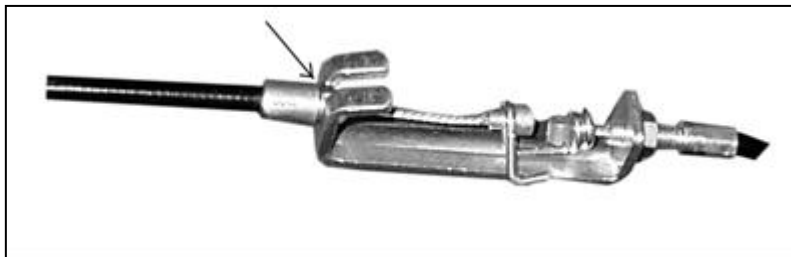

Drop down the Connector so the fitting sits firmly on top of the bracket.

NOTE: In able to hold the Front Post while connecting the cables and wires, extra help may be needed

STEP 3

1. Attach the handlebar (#19) to the front post (#22), tighten with a C-Clip (#25), Allen bolt (#25), decorative cover (#27) and T-type knob (#28).
2. Connect the upper sensor wire from the back of the computer (#18) to the middle sensor wire (#24).
3. Insert the lower pulse wire (#43) through the grommet (#75) on the front post (#22) and pull the middle sensor wire (#43) out of front post (#22)
4. Connect lower pulse wire (#43) with the upper pulse wire from the back of the computer (#18).
5. Attach computer (#18) to bracket on the front post (#22), tighten with four screws (#29).

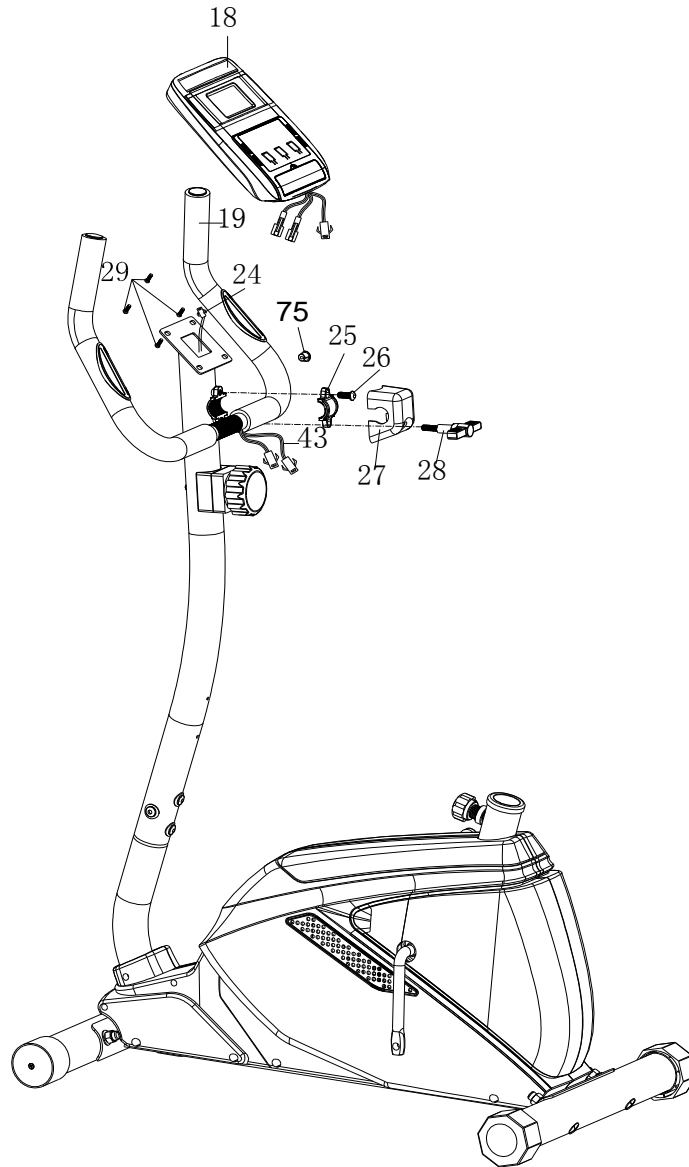

STEP 4

1. Attach the seat pad (#16) to the seat post (#15), tighten with knob (#34), sleeve (#33), washer (#32) and bowl shaped nut (#31)).
2. Insert the seat post (#15) into the main frame (1) and tighten with quick release knob (#11).

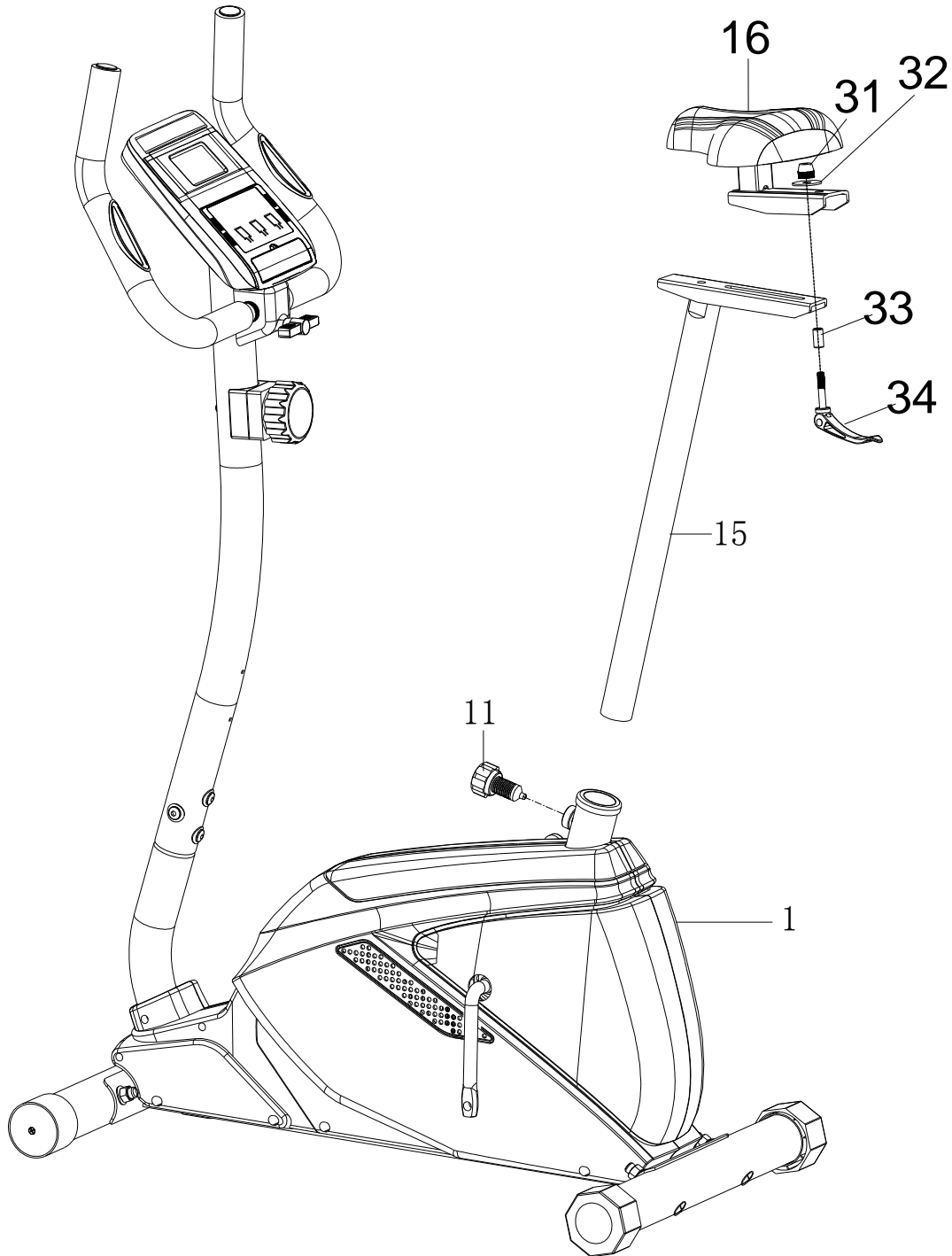

STEP 5

1. Attach the bottle holder (#41) to the front post (#22) with two self-tapping screws (#70).
2. Attach the left and right pedal straps to the left and right pedals (#9/#10).
3. Attach the left and right pedals (#9/#10) to the left and right crank arms.

Note: The pedals and crank arms are marked with "R" and "L" stickers. The left pedal (L) should be threaded on clockwise and the right pedal (R) should be threaded on counter-clockwise.

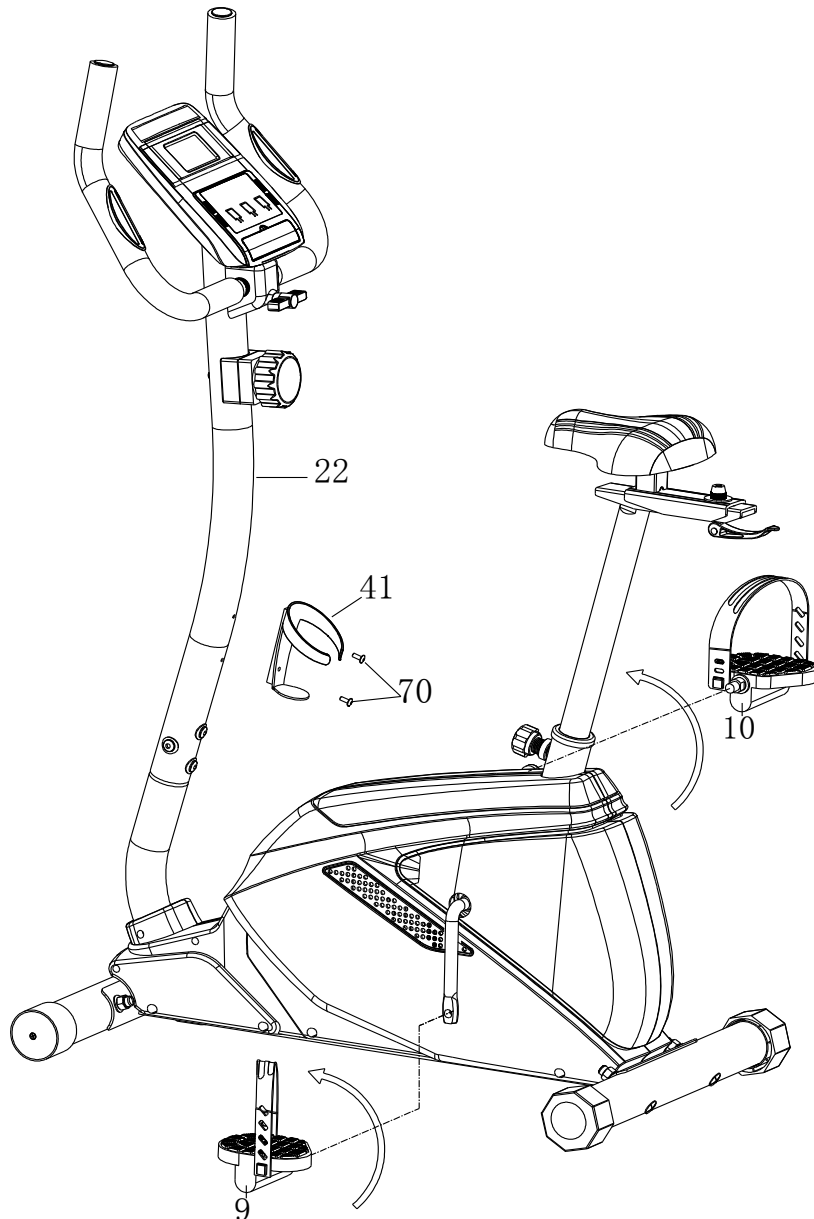

EXPLODED DIAGRAM

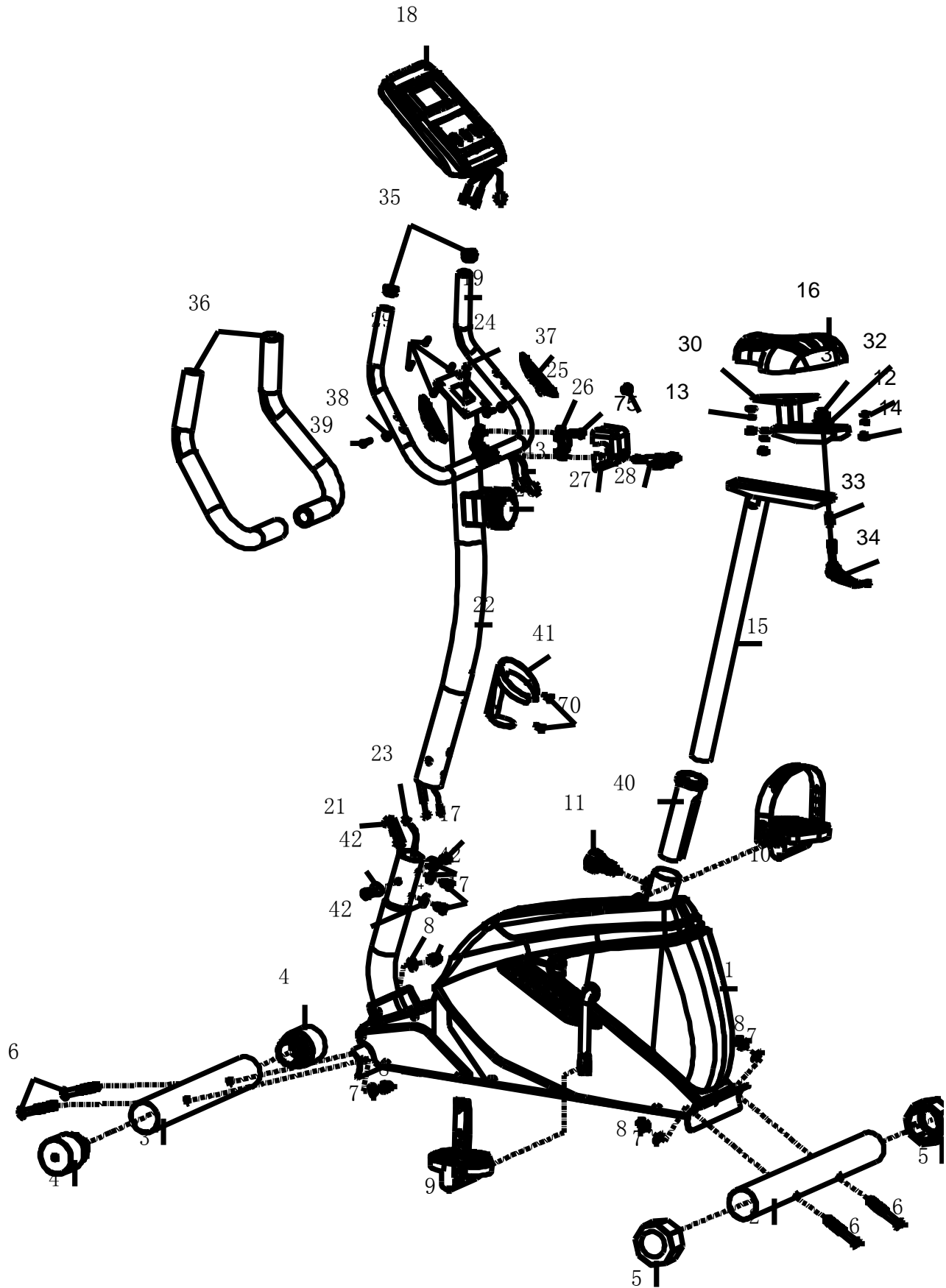

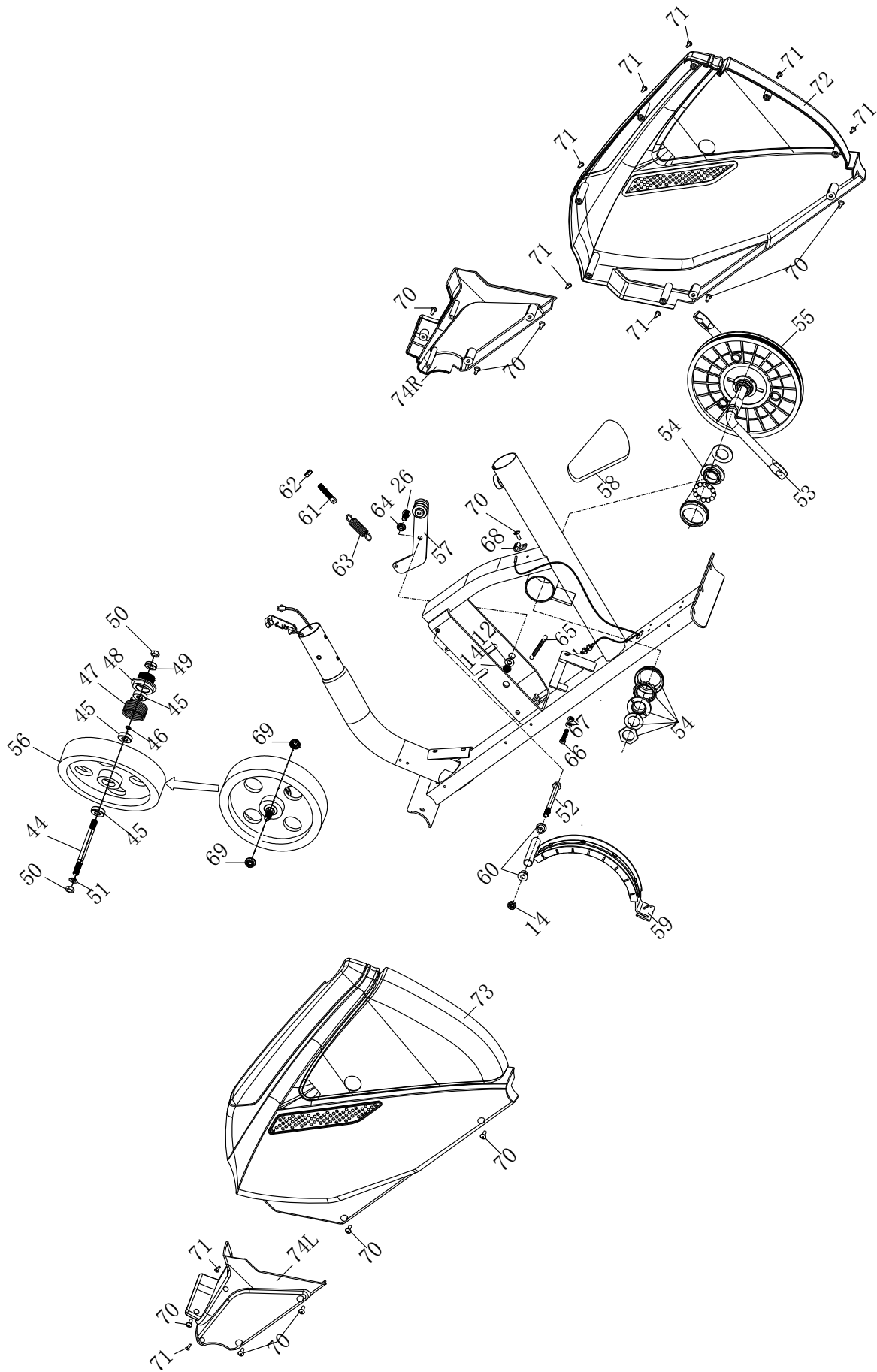

ME-1016U PARTS LIST

PART NO.	DESCRIPTION	Q'TY
1	Main Frame	1
2	Rear Stabilizer	1
3	Front Stabilizer	1
4	End Cap For Front Stabilizer	2
5	End Cap For Rear Stabilizer	2
6	Carriage Bolt M10x3"	4
7	Curved Washer $\Phi\frac{3}{8}$ "	4
8	Domed Nut M10	4
9	Left Pedal	1
10	Right Pedal	1
11	Quick Release Knob	1
12	Washer	4
13	Locking Washer	3
14	Aircraft Nut M8	5
15	Seat Post	1
16	Seat	1
17	Allen Bolt M8x $\frac{5}{8}$ "	4
18	Computer	1
19	Handlebar	1
20	Tension control w/ upper cable wire	1
21	Lower tension cable	1
22	Front Post	1
23	Lower Sensor Wire	1
24	Middle Sensor Wire	1
25	Clip	1
26	Allen Bolt M8x $\frac{3}{4}$ "	2
27	Decorative Cover for Clip	1
28	T-Type Knob	1
29	Screw M5x $\frac{1}{2}$ "	4
30	Sliding Tube	1
31	Bowl Shaped Nut	1
32	Washer	1
33	Sleeve	1
34	Knob	1
35	End Cap	2
36	Foam Grip for Handlebar	2
37	Hand Pulse Sensor	2
38	Washer	2

PART NO.	DESCRIPTION	Q'TY
39	Screw	2
40	Bushing	1
41	Bottle holder	1
42	Curved Washer $\Phi\frac{1}{2}$ "	4
43	Lower Pulse Wire	2
44	Axle for Flywheel	1
45	Bearing	3
46	Washer	1
47	Spring Clutch	1
48	Small pulley	1
49	Bearing	1
50	Nut M10	2
51	Bowl Shaped Spacer	1
52	Allen Bolt M8x4"	1
53	Crank	1
54	Ball Bearing assembly	1
55	Pulley	1
56	Flywheel	1
57	Idler Assembly	1
58	Belt	1
59	Magnetic Assembly	1
60	Spacer	2
61	Hex Bolt M8x1 $\frac{3}{4}$ "	1
62	Nut M6	1
63	Spring	1
64	Spacer	1
65	Spring	1
66	Hex Head Bolt M6x1"	1
67	Nut M6	2
68	Sensor Bracket	1
69	French nut	2
70	Self-Tapping Screw	13
71	Self-Tapping Screw ST5x $\frac{3}{8}$ "	9
72	Chain Cover L	1
73	Chain Cover R	1
74	Decorative Cover	1/1
75	Grommet	1

COMPUTER



FUNCTIONAL BUTTONS:

MODE - Push down for selecting functions.

SET - To set the time, distance, calories and hand pulse.

RESET - For resetting time, distance, calories and hand pulse.

FUNCTION AND OPERATIONS:

- 1. SCAN:** Press "MODE" button until "SCAN" appears, monitor will cycle through all the 6 functions: Time, speed, distance, calorie ODO and pulse. Each function will display for 6 seconds.
- 2. TIME:** (1) Count the total time of exercise from start to end.
(2) Press "MODE" button until "TIME" appears, press "SET" button to set exercise time. When the "set" is zero, the computer will sound an alarm for 15 seconds.
- 3. SPEED:** Display current speed.
- 4. DIST:** (1) Count the distance of exercise from start to end.
(2) Press "MODE" button until "DIST" appears. Press "SET" button to set exercise distance. When the "set" is zero, the computer will sound an alarm for 15 seconds.
- 5. CALORIES:** (1) Count the total calories of exercise from start to end.
(2) Press "MODE" button until "CAL" appears. Press "SET" button to set exercise calories. When the "set" is zero, the computer will sound an alarm for 15 seconds.
- 6. ODO :** Monitor will display the total accumulated distance.
- 7. PULSE:** Press MODE button until "PULSE" appears. Before measuring your pulse rate, please place the palms of your hands on both contact pads and the monitor will show your current heart beat rate in beats per minute(BPM) on the LCD after 6~7 seconds.
Note: During the pulse measurement, the measured value may be higher than the actual pulse rate during the first 2~3 seconds, then will return to normal level. The PULSE Function value cannot be regarded as the basis of medical treatment.

Press "MODE" button until "PULSE" appears. Press "SET" button to set exercise pulse. The setting values of 40-240 RPM , the computer will sound alarm when heart rate is below the SET value.

NOTE:

1. If the display is faint or does not show any digits, please replace the batteries.
2. The monitor will automatically shut off after 4 minutes of inactivity.

SPECIFICATIONS:

FUNCTION	AUTO SCAN	Every 6 seconds
	TIME	00:00'~99:59'
	CURRENT SPEED	The maximum signal can be pickup is 99.9M/H
	TRIP DISTANCE	0.00~99.99M or 0.00~9999M
	CALORIES	0.1~999.9kCAL
	ODO	0.1~999.9M or 1 ~ 9999M
	PULSE RATE	40~240BPM
BATTERY TYPE		2pcs of SIZE –AA or UM –3
OPERATING TEMPERATURE		0°C ~ +40°C
STORAGE TEMPERATURE		-10°C ~ +60°C

EXERCISE GUIDELINES

Using your **Magnetic Upright Bike** will provide you with several benefits, it will improve your physical fitness, tone muscle and in conjunction with calorie controlled diet help you lose weight.

1. The Warm Up Phase

This stage helps get the blood flowing around the body and the muscles working properly. It will also reduce the risk of cramp and muscle injury. It is advisable to do a few stretching exercises as shown below. Each stretch should be held for approximately 30 seconds, do not force or jerk your muscles into a stretch - if it hurts, STOP.

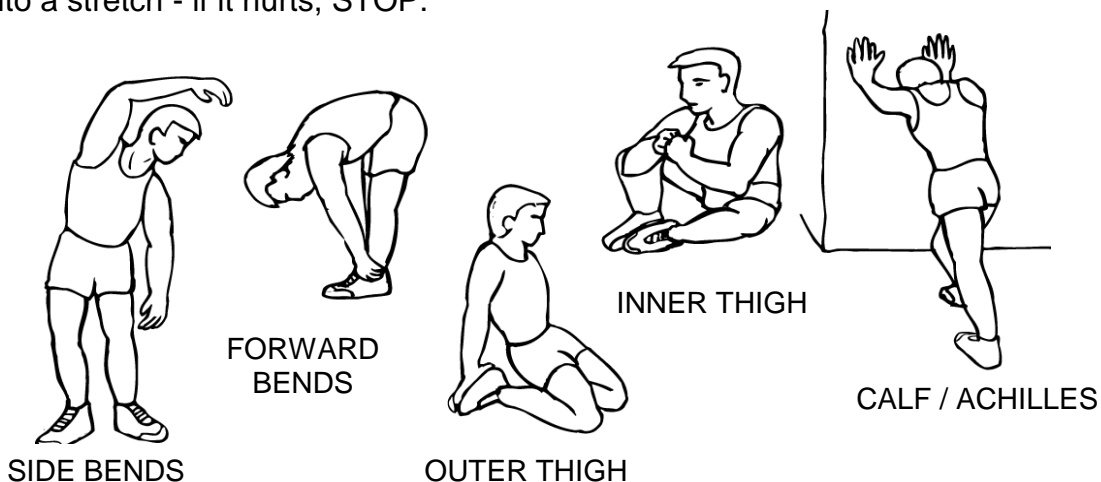

2. The Exercise Phase

This is the stage where you put the effort in. After regular use, the muscles in your legs will become more flexible. Work to your targeted heart rate but it is very important to maintain a steady tempo throughout. The rate of work should be sufficient to raise your heartbeat into the target zone shown on the graph below.

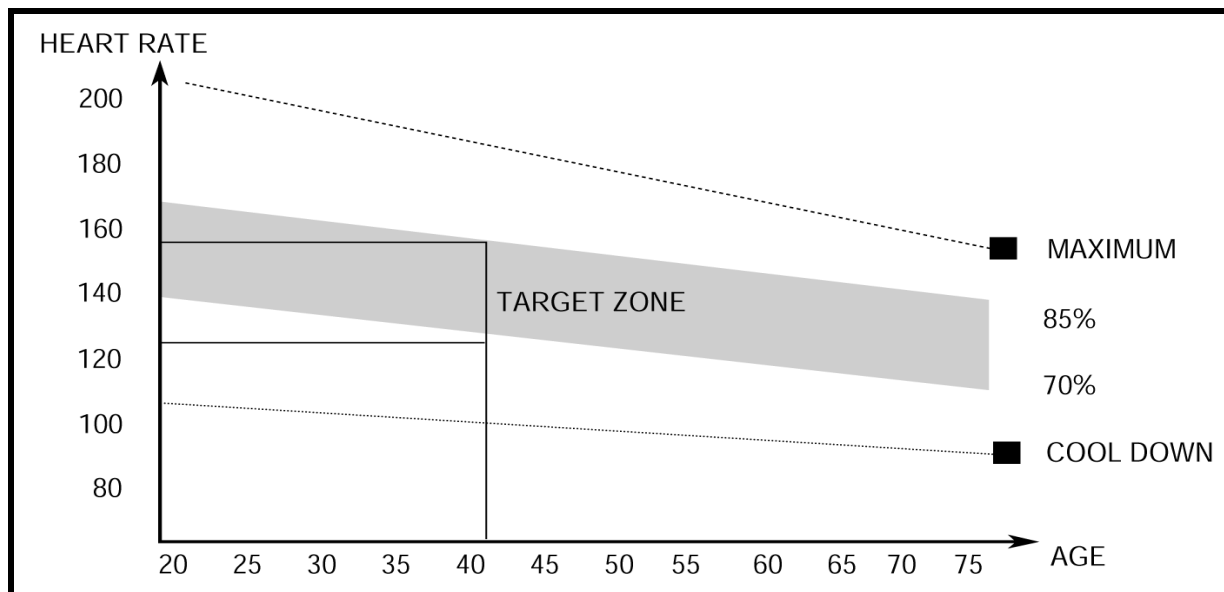

This stage should last for a minimum of 12 minutes though most people start at about 15-20 minutes

3. The Cool Down Phase

This stage is to let your Cardio-vascular System and muscles wind down. This is a repeat of the warm up exercise e.g. reduce your tempo, continue for approximately 5 minutes. The stretching exercises should now be repeated, again remembering not to force or jerk your muscles into the stretch.

As you get fitter you may need to train longer and harder. It is advisable to train at least three times a week, and if possible space your workouts evenly throughout the week.

MUSCLE TONING

To tone muscle while on your **Magnetic Upright Bike** you will need to have the resistance set quite high. This will put more strain on our leg muscles and may mean you cannot train for as long as you would like. If you are also trying to improve your fitness you need to alter your training program. You should train as normal during the warm up and cool down phases, but towards the end of the exercise phase you should increase resistance making your legs work harder. You will have to reduce your speed to keep your heart rate in the target zone.

WEIGHT LOSS

The important factor here is the amount of effort you put in. The harder and longer you work the more calories you will burn. Effectively this is the same as if you were training to improve your fitness, the difference is the goal.

IMPEX[®] INC.

LIMITED WARRANTY

IMPEX Inc. ("IMPEX[®]") warrants this product to be free from defects in workmanship and material, under normal use and service conditions, for a period of two years on the Frame from the date of purchase. This warranty extends only to the original purchaser. IMPEX's obligation under this Warranty is limited to replacing or repairing, at IMPEX's option.

All returns must be pre-authorized by IMPEX. Pre-authorization may be obtained by calling IMPEX Customer Service Department at 1-800-999-8899. All freights for products return to IMPEX must be prepaid by the customer. This warranty does not extend to any product or damage to a product caused by or attributable to freight damage, abuse, misuse, improper or abnormal usage or repairs not provided by an IMPEX authorized service center or for products used for commercial or rental purposes. No other warranty beyond that specifically set forth above is authorized by IMPEX.

IMPEX is not responsible or liable for indirect, special or consequential damages arising out of or in connection with the use or performance of the product or other damages with respect to any economic loss, loss of property, loss of revenues or profits, loss of enjoyments or use, costs of removal, installation or other consequential damages or whatsoever natures. Some states do not allow the exclusion or limitation of incidental or consequential damages. Accordingly, the above limitation may not apply to you.

The warranty extended hereunder is in lieu of any and all other warranties and any implied warranties of merchantability or fitness for a particular purpose is limited in its scope and duration to the terms set forth herein. Some states do not allow limitations on how long an implied warranty lasts. Accordingly, the above limitation may not apply to you.

This warranty gives you specific legal right. You may also have other rights which vary from state to state. **Register on-line www.marcypro.com**

**IMPEX[®] INC.
2801 S. Towne Ave.
Pomona, CA 91766**

ORDERING REPLACEMENT PARTS

Replacement parts can be ordered by calling our Customer Service Department toll-free at **1-800-999-8899** during our regular business hours: Monday through Friday, 9 am until 5 pm Pacific standard time.

support@impex-fitness.com

When ordering replacement part, always give the following information.

1. Model
2. Description of Parts
3. Part Number
4. Date of Purchase