

NOTE:
Please read all instructions
carefully before using this
product

Table of Contents

Safety Notice

Hardware Identifier

Assembly Instructions

Exploded Diagram

Parts List

Warranty

Ordering Parts

Model
MWB ECLIPSE

Retain This
Manual for
Reference

July 17, 1999
OWNER'S
MANUAL



MARCY[®]
By IMPEX

MARCY ECLIPSE

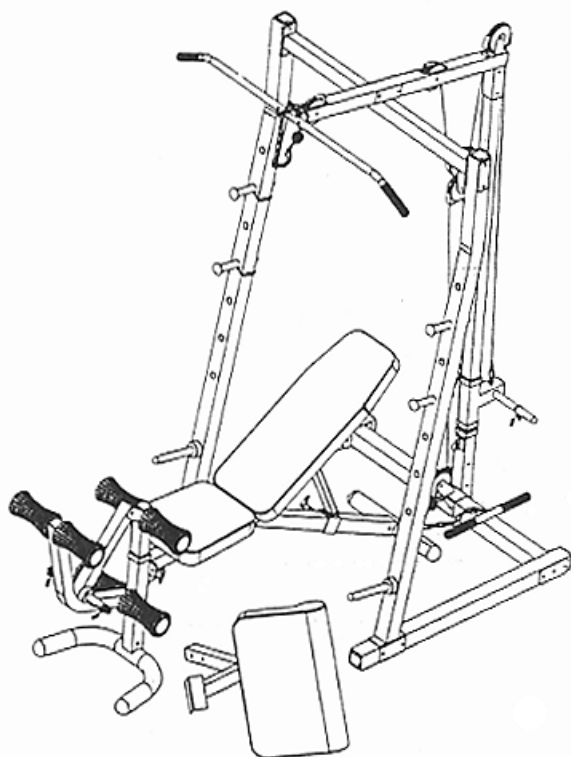

IMPEX INC.

14777 Don Julian Rd. ,City of Industry, CA 91746

Tel: (800)999-8899 Fax: (626)961-9966

www.impex-fitness.com
impex@impex-fitness.com

TABLE OF CONTENTS

BEFORE YOU BEGIN	1
IMPORTANT NOTICE	2
HARDWARE IDENTIFIER	3
ASSEMBLY INSTRUCTIONS	4
EXPLODED DIAGRAM	10
PARTS LIST	12
WARRANTY	13
ORDERING PARTS	13

BEFORE YOU BEGIN

Thank you for selecting the Marcy ECLIPSE by Impex Fitness PRODUCTS. For your safety and benefit, read this manual carefully before using the machine. As a manufacturer, we are committed to provide you complete customer satisfaction. If you have any questions, or find there are missing or damaged parts, we guarantee you complete satisfaction through direct assistance from our factory. To avoid unnecessary delays, please call our TOLL-FREE customer service number. Our Customer Service Agents will provide immediate assistance to you.

TOLL-Free Customer Service Number

1-800-999-8899

Mon. - Fri. , 9 a.m. - 5 p.m. PST

www.impex-fitness.com

impex@impex-fitness.com

IMPORTANT SAFETY NOTICE

PRECAUTIONS

This exercise machine is built for optimum safety. However, certain precautions apply whenever you operate a piece of exercise equipment. Be sure to read the entire manual before you assemble or operate your machine. In particular, note the following safety precautions:

1. **Keep children and pets away from the machine at all times. DO NOT leave children unattended in the same room with the machine.**
2. Only one person at a time should use the machine.
3. If the user experiences dizziness, nausea, chest pain, or any other abnormal symptoms, STOP the workout at once. **CONSULT A PHYSICIAN IMMEDIATELY.**
4. Position the machine on a clear, leveled surface. **DO NOT** use the machine near water or outdoors.
5. Keep hands away from all moving parts.
6. Always wear appropriate workout clothing when exercising. **DO NOT** wear robes or other clothing that could become caught in the machine. Running or aerobic shoes are also required when using the machine.
7. Use the machine only for its intended use as described in this manual. **DO NOT** use attachments not recommended by the manufacturer.
8. Do not place any sharp object around the machine.
9. Disabled person should not use the machine without a qualified person or physician in attendance.
10. Before using the machine to exercise, always do stretching exercises to properly warm up.
11. Never operate the machine if the machine is not functioning properly.

WARNING: BEFORE BEGINNING ANY EXERCISE PROGRAM, CONSULT YOUR PHYSICIAN. THIS IS ESPECIALLY IMPORTANT FOR INDIVIDUALS OVER THE AGE OF 35 OR PERSONS WITH PRE-EXISTING HEALTH PROBLEMS. READ ALL INSTRUCTIONS BEFORE USING ANY FITNESS EQUIPMENT. IMPEX INC. ASSUMES NO RESPONSIBILITY FOR PERSONAL INJURY OR PROPERTY DAMAGE SUSTAINED BY OR THROUGH THE USE OF THIS PRODUCT.

SAVE THESE INSTRUCTIONS.

HARDWARE IDENTIFIER

PLACE WASHER, END OF BOLT , OR SCREW ON CIRCLE TO CHECK FOR CORRECT SIZE.

MILLIMETERS

M6



M8



M10



INCHES

1/2"

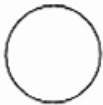

5/8"

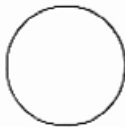

3/4"

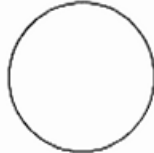

REPLACEMENT PARTS

Thank you for purchasing IMPEX product. Although we go to great effort to ensure the quality of our products, occasionally errors or omissions occur. Should you find either a defective or missing part in this product, please contact us for a replacement at the telephone number.

QUESTION ?



1-800-999-8899

NOTE: When installing a Aircraft Nut (also called Nylon or Lock Nut), Please use two adjustable wrenches to tighten down the Nut. Hold down the Bolt with one wrench, and use the other wrench to turn the Nut clockwise.

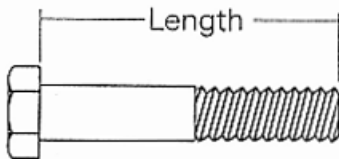

HEX HEAD BOLT

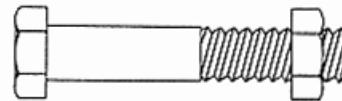

AIRCRAFT NUT



FLAT WASHER



ROUND PLUG

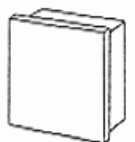

SQUARE PLUG

ASSEMBLY INSTRUCTION

Tools required to assembly the machine:

Two Adjustable Wrenches

Two Allen Wrenches

NOTE: It is strongly recommended that this machine be assembled by two or more people to avoid possible injury.

STEP 1 (SEE DIAGRAM 1)

- A.) Place the Lower Cross Brace (#3) on the floor. Attach a Base Frame (#2) to the Cross Brace and secure it with two M10x3 1/8" Bolts (#60), four Ø7/8" Washers (#64), one 2 3/8"x5 1/8" Bracket (#4), and two M10 Aircraft Nuts (#70).
- B.) Repeat the above procedure to install another Base Frame.
- C.) Attach an Upright Beam (#1) to the Base Frame (#2). Secure it with two M10x3 1/8" Bolts (#60), four Ø7/8" Washers (#64), and two M10 Aircraft Nuts (#70).
- D.) Repeat the above procedure C to install another Upright Beam on the other side.
- E.) Connect both Upright Beams (#1) on the top with an Upper Cross Brace (#11). Secure it with two M10x3 1/8" Bolts (#60), four Ø7/8" Washers (#64), one 4 3/4"x2" Bracket (#19), and two M10 Aircraft Nuts (#70) on each side of the Cross Brace.
- F.) Attach the Guide Rod Base (#5) to the Lower Cross Brace (#3) in the middle. Secure it with two M10x3 1/8" Bolts (#60), four Ø7/8" Washers (#64), and two M10 Aircraft Nuts (#70).
- G.) Slide the Glider (#6) onto the Chrome Guide Rod (#7). Attach the Chrome Guide Rod to the Guide Rod Base (#5). Secure it with two M10x2 1/2" Bolts (#58), four Ø7/8" Washers (#64) and two M10 Aircraft Nuts (#70).
- H.) Attach the Upper Frame (#10) to the top of the Chrome Guide Rod (#7) on the back and the Upper Cross Brace (#11) on the front. Secure the back with two M10x2 1/2" Bolts (#58), four Ø7/8" Washers (#64), and two M10 Aircraft Nuts (#70). Secure the front with two M10x2 3/4" Bolts (#59), four Ø7/8" Washers (#64), and two M10 Aircraft Nuts (#70).
- I.) Attach four Left and Right Bar Catches (#15 & #16) to the Upright Beams (#1).
- J.) Attach a Storage Post (#14) to the Upright Beam (#1). Secure it with a Ø7/8" Washer (#64) and M10x1" Bolt (#55) on the back. Slide a Rubber Bumper (#35) onto the Post. Repeat the procedure to install another Post onto the other Upright Beam.

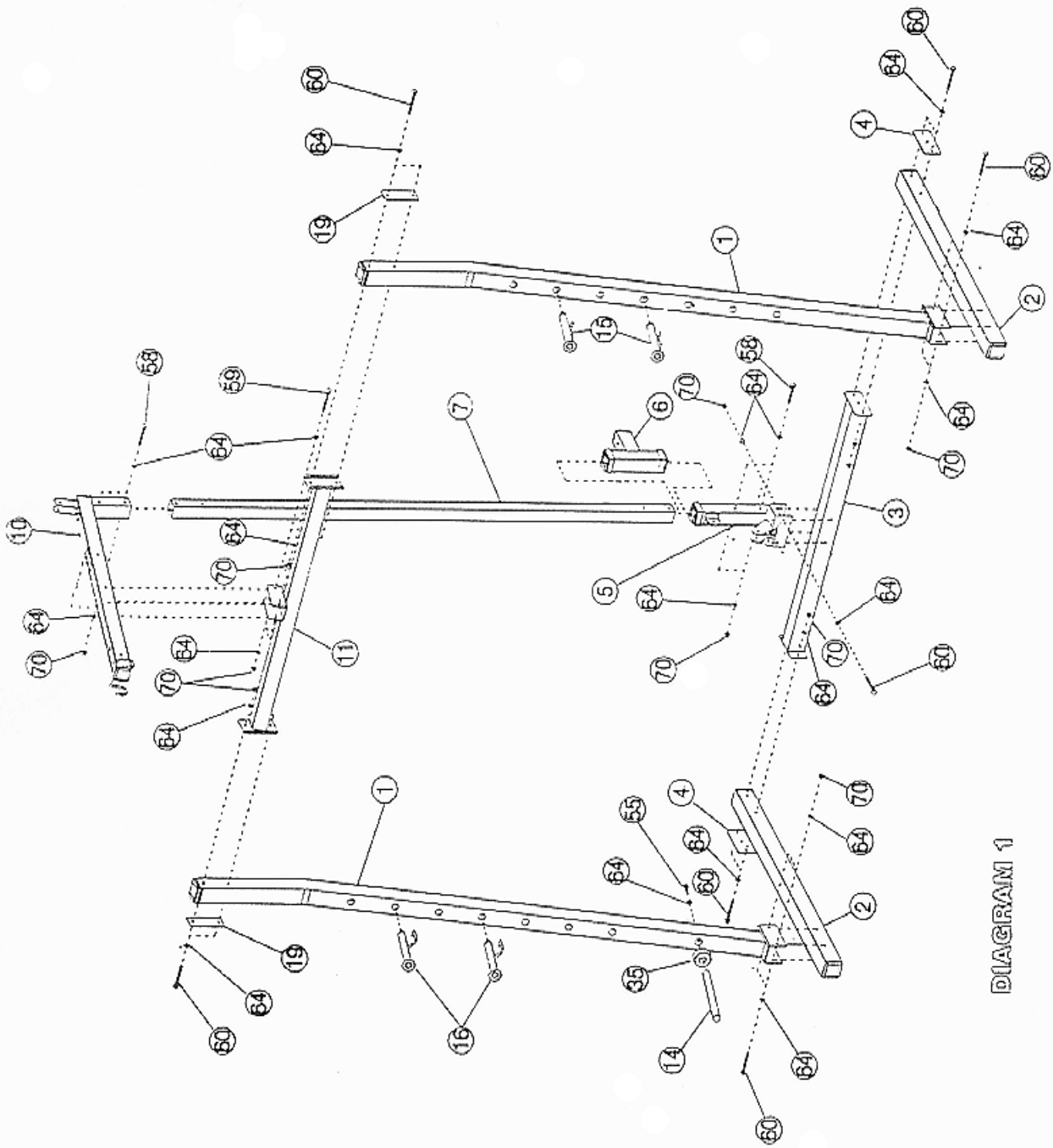
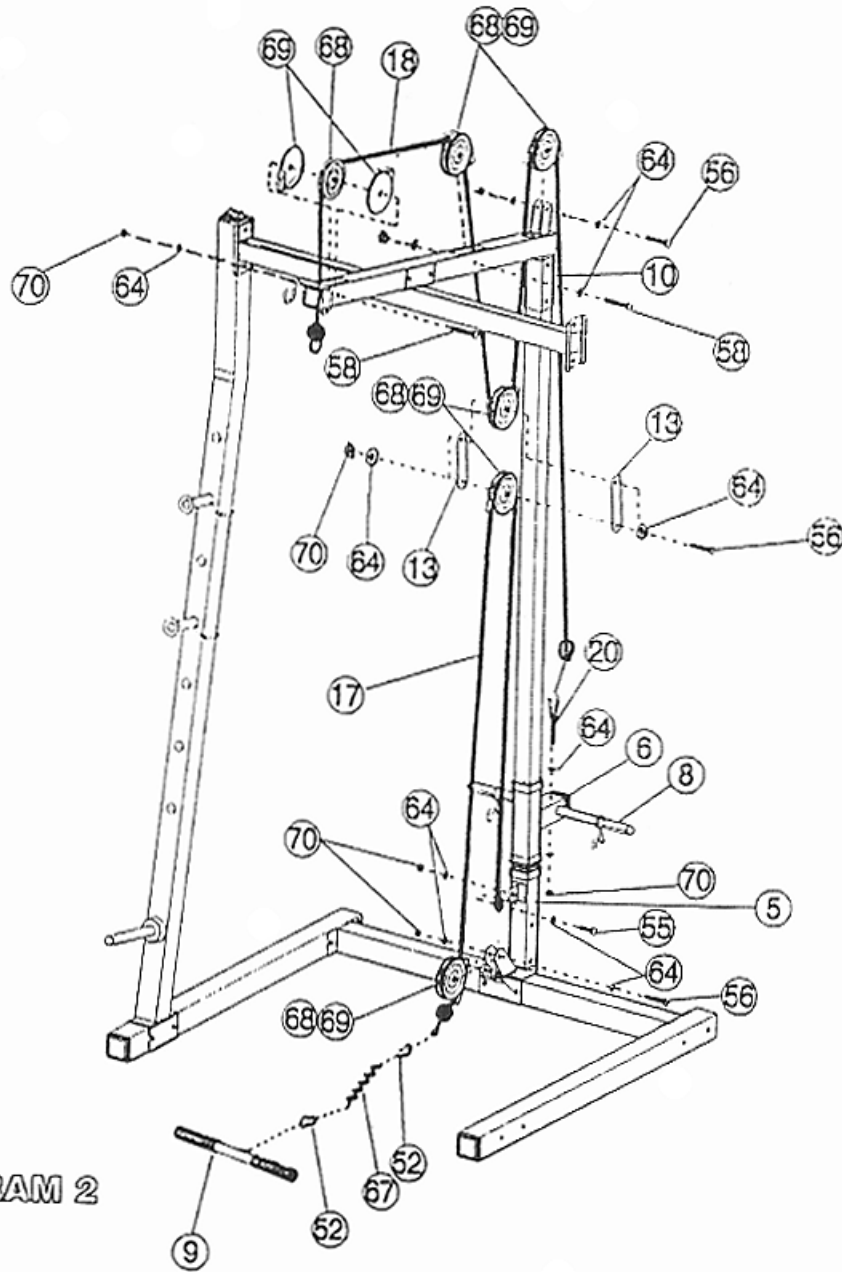

DIAGRAM 1

STEP 2 (SEE DIAGRAM 2)

- A.) Attach the 128" Upper Cable (#18) to the front of the Upper Frame (#10). Attach Pulley (#68) and two Pulley Covers (#69) to the Cable. Align the holes on the Pulley to the Upper Frame and secure it with one M10x2 ½" Bolt (#58), two Ø7/8" Washers (#64), and one M10 Aircraft Nut (#70).
- B.) Draw the Cable towards the back of the machine. Install another Pulley Set to the opening on the Upper Frame (#10). Draw the Cable downward through the Upper Frame.
- C.) Install another Pulley Set with two Double Floating Brackets (#13). Secure the Bracket with one M10x1 ¾" Bolt (#56), two Ø7/8" Washers (#64), and one M10 Aircraft Nut (#70). Let the Bracket hanging for now.
- D.) Draw the Cable upward through the opening to the top the Chrome Guide Rod. Install another Pulley Set.
- E.) Draw the Cable over the Pulley Set and downward towards the Glider (#6). Connect the Cable to the Hook Bolt (#20).
- F.) Insert the Chrome Weight Post (#8) halfway through the Glider (#6). Insert the Hook Bolt (#20) into the Glider and secure it with two Ø7/8" Washers (#64) and one M10 Aircraft Nut (#70).
- G.) Attach the 109" Lower Cable (#17) to the bracket on the Guide Rod Base (#5). Install a Pulley Set and secure it with one M10x1 ¾" Bolt (#56), two Ø7/8" Washers (#64), and one M10 Aircraft Nut (#70).
- H.) Draw the Cable upward towards the hanging Double Floating Brackets (#13) previously installed in procedure C above. Install a Pulley Set. Draw the Cable over the Pulley and downward towards the Guide Rod Base (#5). Secure the Cable to the Base with one M10x1" Bolt (#55), two Ø7/8" Washers (#64), and one M10 Aircraft Nut (#70).
- I.) Attach the Curl Bar (#9) to the beginning of the Cable with two Clips (#52) and one Chain (#67).



STEP 3 (SEE DIAGRAM 3)

- A.) Attach the Front Leg (#24) to the Front Stabilizer (#28). Secure it with three $\text{Ø}7/8"$ Washers (#64) and M10 x $5/8"$ Bolts (#54).
- B.) Slide the Sliding Block (#30) onto the Main Seat Support (#23). Attach the Main Seat Support to the Front Leg (#24). Secure it with two M10x1" Bolts (#55), four $\text{Ø}7/8"$ Washers (#64), and two M10 Aircraft Nuts (#70).
- C.) Attach the Rear Stabilizer (#27) to the back of the Main Seat Support (#23). Secure it with two $\text{Ø}7/8"$ Washers (#64) and M10 x $5/8"$ Bolts (#54).
- D.) Attach the Seat (#37) onto the brackets on the Main Seat Support (#23). Align the holes and install four $\text{Ø}1/2"$ Washers (#66) and M6 x $1\ 3/8"$ Bolts (#62).
- E.) Attach the Backrest Adjustment Bar (#31) to the Sliding Block (#30) and secure it with one M10 x $2\ 7/8"$ Bolt (#57), two $\text{Ø}7/8"$ Washers (#64), and one M10 Aircraft Nut (#70).
- F.) Insert the Backrest Pivot Rod (#32) into the front opening on the Backrest Adjustment Bar (#31). Attach one Backrest Support (#29) to the Pivot welded on the Main Seat Support (#23). Raise up the Backrest Support (#29) to align the hole with the Backrest Pivot Rod (#32). Push the Rod into the hole on the Support. Install another Backrest Support on the other side.
- G.) Place the Backrest Board (#38) onto the Backrest Supports (#29). Align the four holes and secure it with four $\text{Ø}1/2"$ Washers (#66) and M6 x $1\ 3/8"$ Bolts (#62).
- H.) Insert the Arm Curl Stand (#22) into the opening on the Front Leg (#24). Secure the Stand with a Pull Pin (#53).
- I.) Attach the Arm Curl Pad (#36) to the top of the Arm Curl Stand (#22) and secure it with two $\text{Ø}3/4"$ Washers (#65) and M8 x $5/8"$ Bolts (#61).

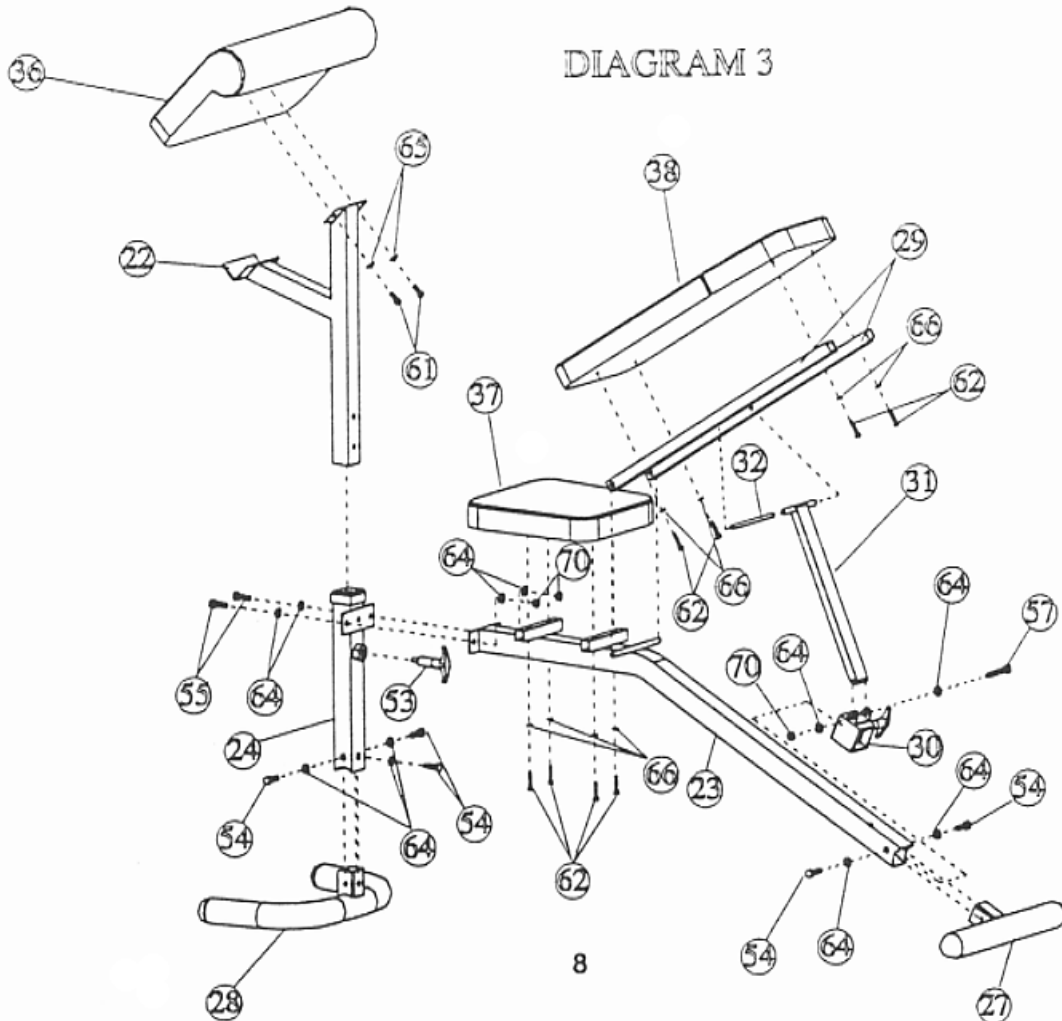

STEP 4 (See Diagram 4)

- A.) Release the Pull Pin and pull the Arm Curl out from the Front Leg.
- B.) Insert the Leg Developer Holder (#25) into the opening. Attach the Leg Developer (#26) to the bracket on the Holder. Secure it with one Axle (#49), two $\text{\O}3/4"$ Washers (#65), and two M8x5/8" Allen Bolts (#71).
- C.) Insert three Foam Roll Tubes (#33) halfway through the holes on the Leg Developer (#26) and its Holder (#25). Push six Foam Rolls (#50) onto the Tubes from both sides. Plug six End Caps (#46) to the end of the Tubes.
- D.) Slide the Weight Post (#34) halfway through the Leg Developer (#26). Push two Rubber Bumpers (#35) onto the Post. Attach two $\text{\O}1"$ Spring Clips (#51) to the Post.

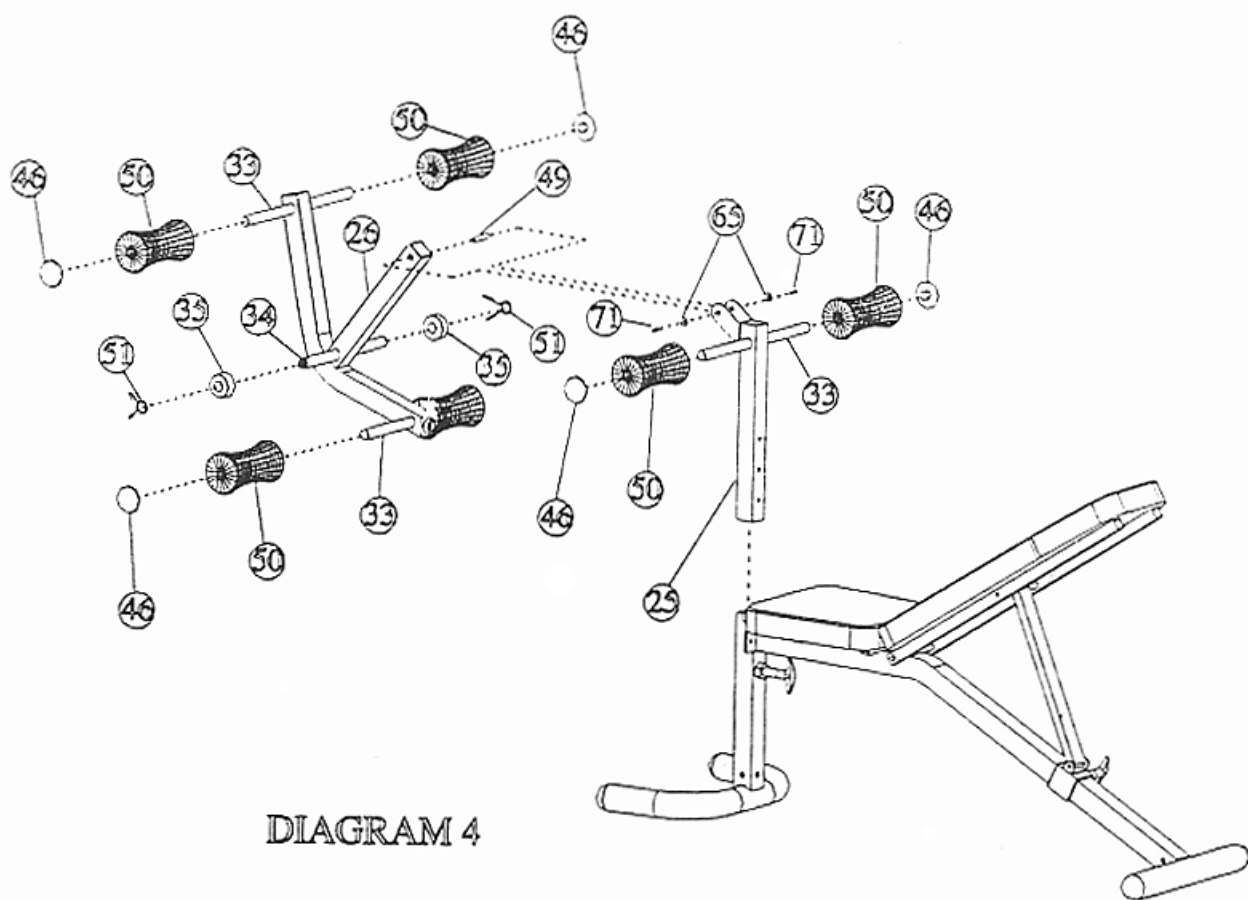

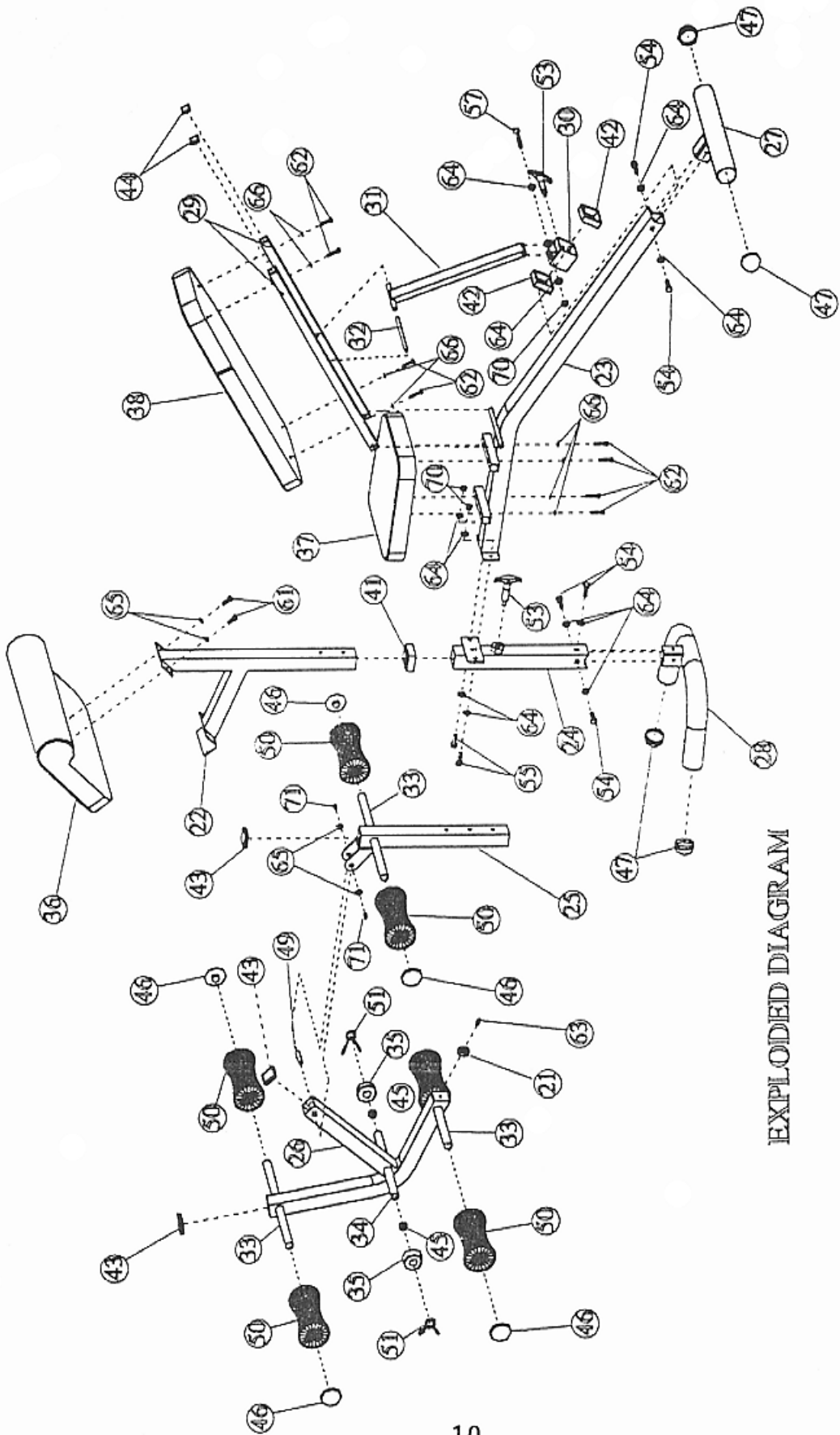

EXPLODED DIAGRAM

MWB ECLIPSE

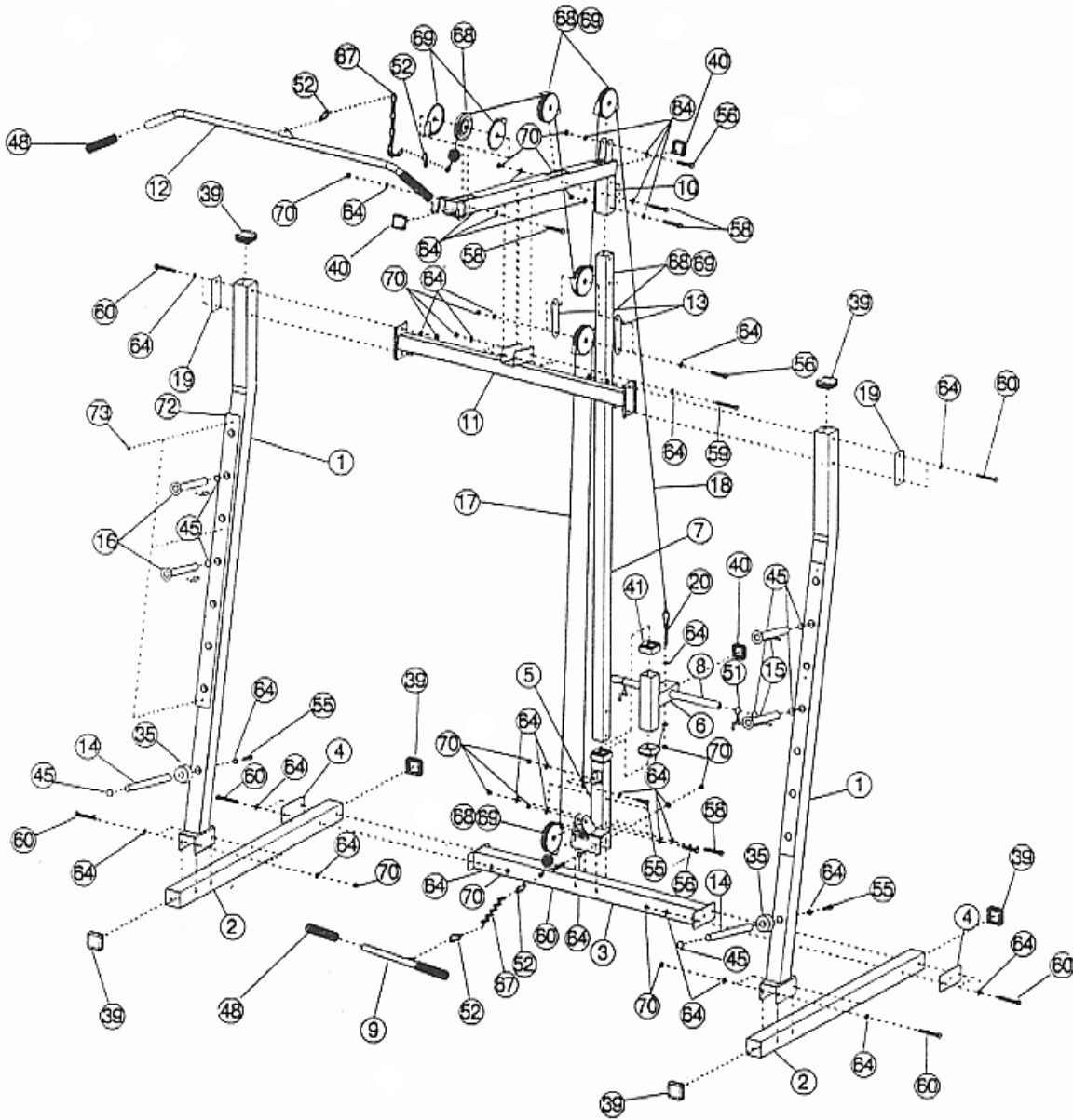

ECLIPSE PARTS LIST

<u>Part No.</u>	<u>Description</u>	<u>QTY</u>	<u>Part No.</u>	<u>Description</u>	<u>QTY</u>
1	Upright Beams	2	41	2" Sleeve	4
2	Base Frame	2	42	2 3/8" Sleeve	2
3	Lower Cross Brace	1	43	2 3/4" Square End Cap	3
4	2 3/8" x 5 1/8" Bracket	2	44	1" Square End Cap	2
5	Guide Rod Base	1	45	Ø1" Round End Cap	8
6	Glider	1	46	Foam End Cap	6
7	Chrome Guide Rod	1	47	2 3/8" Round End Cap	4
8	Weight Post	1	48	Grip	4
9	Curl Bar	1	49	Axle	1
10	Upper Frame	1	50	Foam Roll	6
11	Upper Cross Brace	1	51	Ø1" Spring Clip	4
12	Lat Bar	1	52	Clip	4
13	Double Floating Bracket	2	53	Pull Pin	2
14	Storage Post	2	54	M10 x 5/8" Bolt	5
15	Left Bar Catch	2	55	M10 x 1" Bolt	5
16	Right Bar Catch	2	56	M10 x 1 1/4" Bolt	4
17	109" Lower Cable	1	57	M10 x 2 7/8" Bolt	1
18	128" Upper Cable	1	58	M10 x 2 1/2" Bolt	6
19	4 3/4" x 2" Bracket	2	59	M10 x 2 3/4" Bolt	2
20	Hook Bolt	1	60	M10 x 3 1/8" Bolt	14
21	Rubber Bumper	1	61	M8 x 5/8" Bolt	2
22	Arm Curl Stand	1	62	M6 x 1 3/8" Bolt	8
23	Main Seat Support	1	63	M6 x 5/8" Screw	1
24	Front Leg	1	64	Ø7/8" Washer	69
25	Leg Developer Holder	1	65	Ø3/4" Washer	4
26	Leg Developer	1	66	Ø1/2" Washer	8
27	Rear Stabilizer	1	67	Chain	2
28	Front Stabilizer	1	68	Pulley	6
29	Backrest Support	2	69	Pulley Cover	12
30	Sliding Block	1	70	M10 Aircraft Nut	31
31	Backrest Adjustment Bar	1	71	M8 x 5/8" Allen Bolt	2
32	Backrest Pivot Rod	1	72	Chrome Plate	2
33	Foam Roll Tube	3	73	Screw	6
34	Weight Post	1			
35	Rubber Bumper	4			
36	Arm Curl Pad	1			
37	Seat	1			
38	Backrest Board	1			
39	2 3/8" Square End Cap	6			
40	2" Square End Cap	3			

IMPEX INC.

LIMITED WARRANTY

IMPEX Inc. ("IMPEX") warrants this product to be free from defects in workmanship and material, under normal use and service conditions, for a period of two years on the Frame from the date of purchase. This warranty extends only to the original purchaser. IMPEX's obligation under this Warranty is limited to replacing or repairing, at IMPEX's option.

All returns must be pre-authorized by IMPEX. Pre-authorization may be obtained by calling IMPEX Customer Service Department at 1-800-999-8899. All freights on products returned to IMPEX must be prepaid by the customer. This warranty does not extend to any product or damage to a product caused by or attributable to freight damage, abuse, misuse, improper or abnormal usage or repairs not provided by a IMPEX authorized service center or for products used for commercial or rental purposes. No other warranty beyond that specifically set forth above is authorized by IMPEX.

IMPEX is not responsible or liable for indirect, special or consequential damages arising out of or in connection with the use or performance of the product or other damages with respect to any economic loss, loss of property, loss of revenues or profits, loss of enjoyments or use, costs of removal, installation or other consequential damages or whatsoever natures. Some states do not allow the exclusion or limitation of incidental or consequential damages. Accordingly, the above limitation may not apply to you.

The warranty extended hereunder is in lieu of any and all other warranties and any implied warranties of merchantability or fitness for a particular purpose is limited in its scope and duration to the terms set forth herein. Some states do not allow limitations on how long an implied warranty lasts. Accordingly, the above limitation may not apply to you.

This warranty gives you specific legal right. You may also have other rights which vary from state to state.

IMPEX INC.
14777 Don Julian
City of Industry, CA 91746

ORDERING REPLACEMENT PARTS

Replacement parts can be ordered by calling our Customer Service Department toll-free at 1-800-999-8899 during our regular business hours: Monday through Friday, 9 am until 5 pm Pacific standard time.

www.impex-fitness.com

impex@impex-fitness.com

When ordering replacement parts, always give the following information.

1. Model
2. Description of Parts
3. Part Number
4. Date of Purchase