

NOTE:
Please read all instructions
carefully before using this
product

Table of Contents

Safety Notice

Hardware Identifier

Assembly Instruction

Parts List

Resistance Chart

Warranty

Ordering Parts

Model
MWM-1509

Retain This
Manual for
Reference

111102

OWNER'S
MANUAL

IMPEX

MARCY[®] HOME GYM

MWM-1509

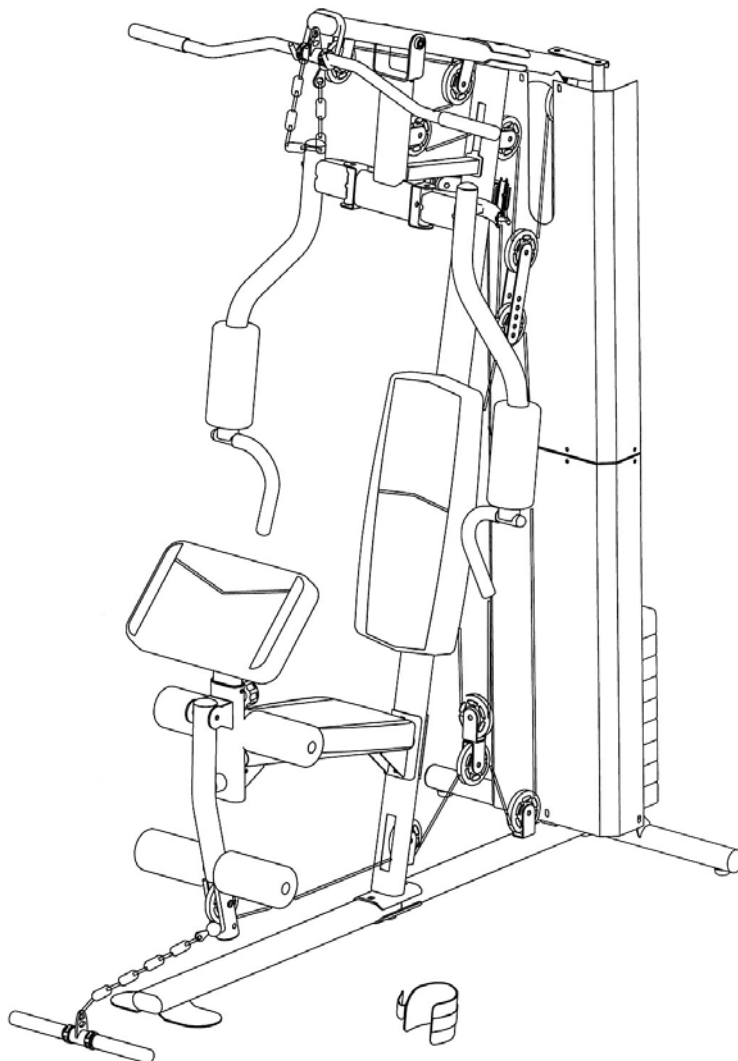

IMPEX[®] INC.

14777 DON JULIAN RD., CITY OF INDUSTRY, CA 91746

Tel: (800) 999-8899 Fax: (626) 961-9966

www.impex-fitness.com

info@impex-fitness.com

TABLE OF CONTENTS

BEFORE YOU BEGIN.....	1
IMPORTANT SAFETY NOTICES.....	2
HARDWARE PACK.....	4
ASSEMBLY INSTRUCTIONS.....	7
EXPLODED DIAGRAM.....	18
PARTS LIST.....	19
RESISTANCE CHART.....	20
WARRANTY.....	21
ORDERING PARTS.....	21

BEFORE YOU BEGIN

Thank you for selecting the MARCY MWM-1509 HOME GYM by IMPEX[®] INC. For your safety and benefit, read this manual carefully before using the machine. As a manufacturer, we are committed to provide you complete customer satisfaction. If you have any questions, or find there are missing or damaged parts, we guarantee you complete satisfaction through direct assistance from our factory. To avoid unnecessary delays, *please call our TOLL-FREE customer service number*. Our Customer Service Agents will provide immediate assistance to you.

Toll-Free Customer Service Number

1-800-999-8899

Mon. – Fri. 9 a.m. – 5 p.m. PST

www.impex-fitness.com

info@impex-fitness.com

IMPORTANT SAFETY NOTICE

PRECAUTIONS

This exercise machine is built for optimum safety. However, certain precautions apply whenever you operate a piece of exercise equipment. **Be sure to read the entire manual and all posted warning labels before you assemble or operate your machine.** In particular, note the following safety precautions:

1. **Keep children and pets away from the machine at all times. DO NOT leave children unattended in the same room with the machine.**
2. Only one person at a time should use the machine.
3. If the user experiences dizziness, nausea, chest pain, or any other abnormal symptoms, STOP the workout at once. CONSULT A PHYSICIAN IMMEDIATELY.
4. Position the machine on a clear, leveled surface. DO NOT use the machine near water or outdoors.
5. Keep hands and feet away from all moving parts.
6. Always wear appropriate workout clothing when exercising. DO NOT wear robes or other clothing that could become caught in the machine. Running or aerobic shoes are also required when using the machine.
7. Use the machine only for its intended use as described in this manual. DO NOT use attachments not recommended by the manufacturer.
8. Do not place any sharp object around the machine.
9. Disabled person should not use the machine without a qualified person or physician in attendance.
10. Before using the machine to exercise, always do stretching exercises to properly warm up.
11. Never operate the machine if the machine is not functioning properly.
12. A spotter is recommended during exercise.
13. Do not intend to insert weight selector pin while the weight stack or top plate is in elevated position.
14. Be certain the weight Selector Pin is completely inserted.
15. Never use dumbbells or other means to increase the weight resistance. Use only weight plates provided by manufacturer.
16. This machine is designed and intended for home and consumer use only.

CARE AND MAINTENANCE

1. Lubricate moving parts with WD-40 or light oil periodically.
2. Inspect and tighten all parts before using the machine.
3. The machine can be cleaned using a damp cloth and mild non-abrasive detergent. DO NOT use solvents.
4. Maximum user's weight: 300 lbs.

WARNING: BEFORE BEGINNING ANY EXERCISE PROGRAM, CONSULT YOUR PHYSICIAN. THIS IS ESPECIALLY IMPORTANT FOR INDIVIDUALS OVER THE AGE OF 35 OR PERSONS WITH PRE-EXISTING HEALTH PROBLEMS. READ ALL INSTRUCTIONS BEFORE USING ANY FITNESS EQUIPMENT. IMPEX INC. ASSUMES NO RESPONSIBILITY FOR PERSONAL INJURY OR PROPERTY DAMAGE SUSTAINED BY OR THROUGH THE USE OF THIS PRODUCT.

SAVE THESE INSTRUCTIONS.

WARNING LABEL REPLACEMENT

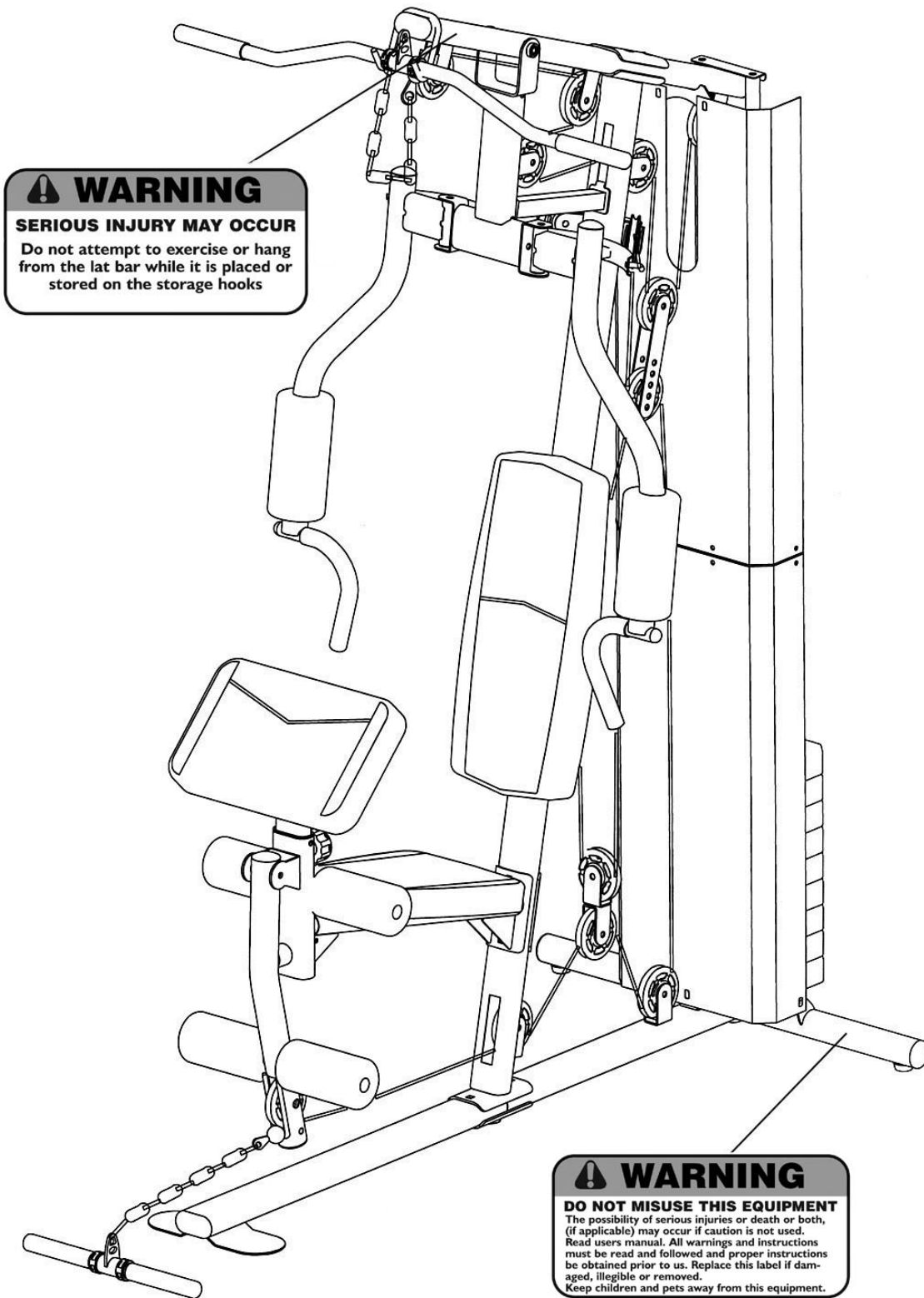

The warning labels shown here have been placed on the Rear Base and Upper Frame. If the labels are missing or illegible, please call customer service at 1-800-888-8899 for replacements. Apply the labels in the location shown.

HARDWARE PACK

NOTE: The following parts are not drawn to scale. Please use your own ruler to measure the size.

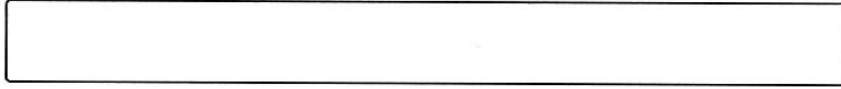

#32 Axle (Qty 1)

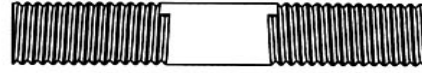

#33 Pulley Bushing (Qty 2)

#48 M10 Stud Bolt (Qty 2)

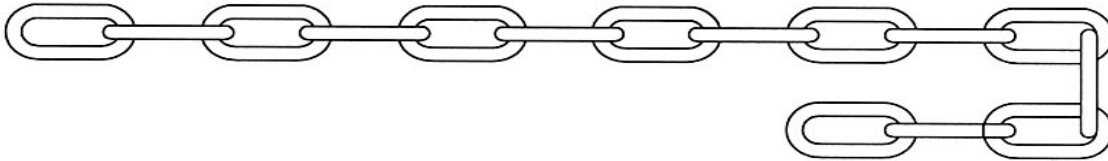

#63 Long Chain (Qty 1)

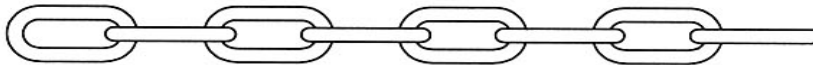

#64 Short Chain (Qty 1)

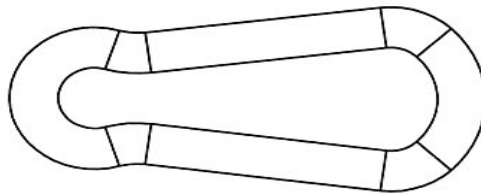

#70 Hook (Qty 4)

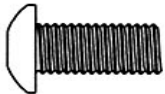

#72 M8 x $\frac{5}{8}$ Allen Bolt (Qty 7)

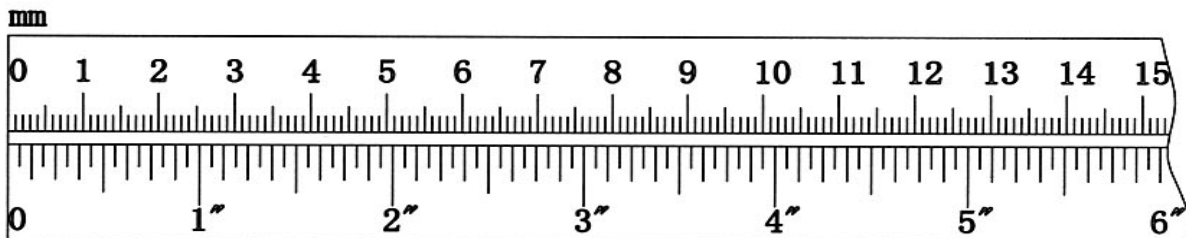

HARDWARE PACK

NOTE: The following parts are not drawn to scale. Please use your own ruler to measure the size.

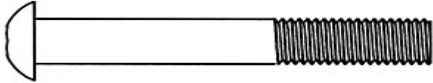

#73 M8 x 2 $\frac{1}{8}$ " Allen Bolt (Qty 2)

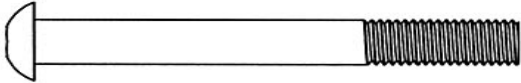

#74 M8 x 2 $\frac{1}{2}$ " Allen Bolt (Qty 2)

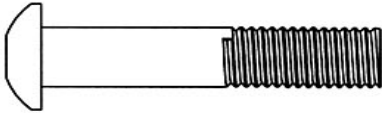

#75 M10 x 1 $\frac{3}{4}$ " Allen Bolt (Qty 13)

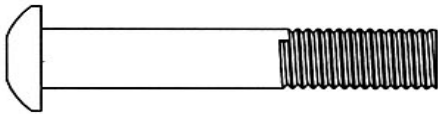

#76 M10 x 2 $\frac{1}{8}$ " Allen Bolt (Qty 2)

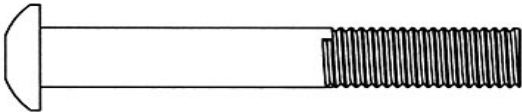

#77 M10 x 2 $\frac{1}{2}$ " Allen Bolt (Qty 3)

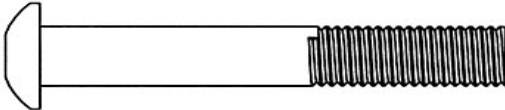

#78 M10 x 2 $\frac{3}{8}$ " Allen Bolt (Qty 1)

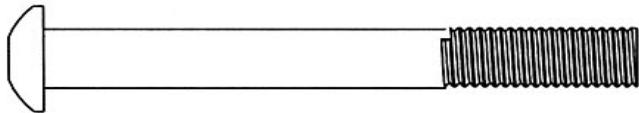

#79 M10 x 3 $\frac{1}{8}$ " Allen Bolt (Qty 1)

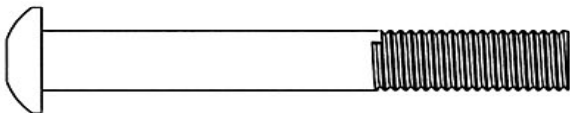

#80 M10 x 2 $\frac{3}{4}$ " Allen Bolt (Qty 2)



#81 M10 x 1" Allen Bolt (Qty 5)

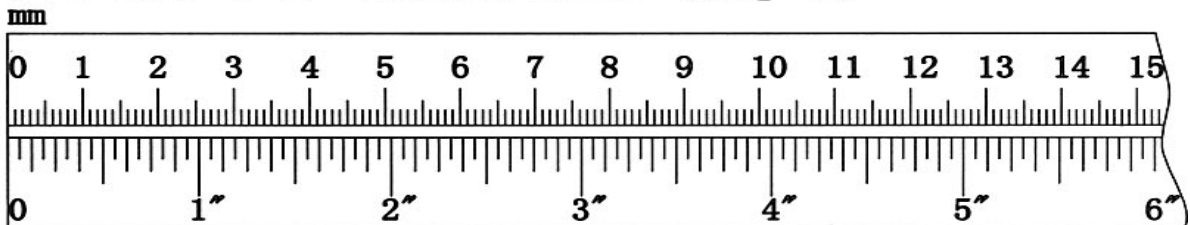

HARDWARE PACK

NOTE: The following parts are not drawn to scale. Please use your own ruler to measure the size.

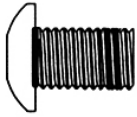

#82 M10 x $\frac{5}{8}$ " Allen Bolt (Qty 2)

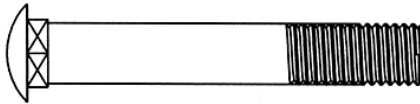

#83 M10 x 2 $\frac{3}{8}$ " Carriage Bolt (Qty 10)

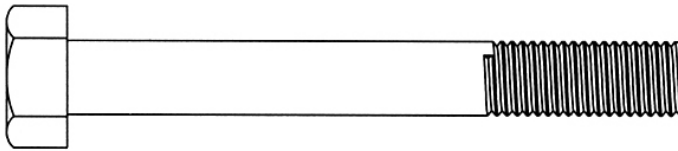

#84 M12 x 4" Hex Bolt (Qty 2)



#85 M6 x $\frac{3}{8}$ " Philips Screw (Qty 8)

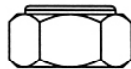

#90 M10 Aircraft Nut (Qty 28)



#91 M12 Aircraft Nut (Qty 2)



#89 M6 Regular Nut (Qty 8)

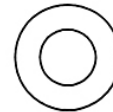

#87 $\varnothing \frac{5}{8}$ " Washer (Qty 11)

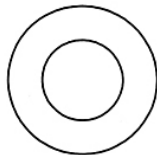

#88 $\varnothing 1$ " Washer (Qty 4)

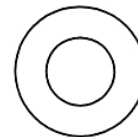

#86 $\varnothing \frac{3}{4}$ " Washer (Qty 55)

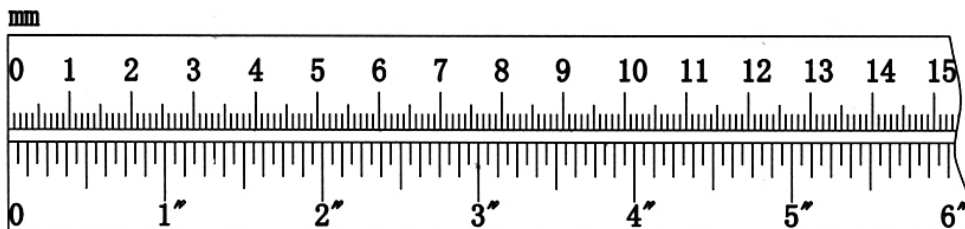

ASSEMBLY INSTRUCTION

Tools Required Assembling the Machine: Two Adjustable Wrenches, two Allen Wrenches, and one Philips Screwdriver. NOTE: It is strongly recommended this machine be assembled by two or more people to avoid possible injury.

STEP 1 (See Diagram 1)

- A.) Connect two Lower Guide Rods (#46) and two Upper Guide Rods (#45) with two M10 Stud Bolts (#48). Firmly thread the Rods together.
- B.) Insert the two Lower Guide Rods (#46) into the holes on the Rear Base Frame (#2). Secure them with two M10 x 1" Allen Bolts (#81) and $\text{\O } \frac{3}{4}$ " Washers (#86) from the bottom. Slide two $\text{\O } 2 \frac{1}{2}$ " x 1" Rubber Bumpers (#62) onto the Guide Rods.
- C.) Attach the Main Base Frame (#1) to the Rear Base Frame (#2). Secure it with two M10 x 2 $\frac{3}{4}$ " Allen Bolts (#80), two $\text{\O } \frac{3}{4}$ " Washers (#86), and one 4" Curved Bracket (#22).
- D.) Make sure the two triangular brackets on the Rear Base Frame are facing toward the front.
- E.) NOTE: Do not tighten all the Nuts and Bolts until instructed to do so.
- F.) Attach the Front Base Frame (#3) to the Main Base Frame.
- G.) Attach the Lower Vertical Frame (#4) onto the Main Base Frame and Front Base Frame. Secure them together with two M10 x 2 $\frac{3}{8}$ " Carriage Bolts (#83), one 5 $\frac{1}{2}$ " Curved Bracket (#6), two $\text{\O } \frac{3}{4}$ " Washers (#86), and two M10 Aircraft Nuts (#90).
- H.) Attach the Seat Support (#5) to the Lower Vertical Frame (#4). Secure it with two M10 x 2 $\frac{3}{8}$ " Carriage Bolts (#83), one 5 $\frac{1}{2}$ " Curved Bracket (#6), two $\text{\O } \frac{3}{4}$ " Washers (#86), and two M10 Aircraft Nuts (#90).
- I.) Attach the Leg Developer (#7) to the Seat Support. Secure it with one M10 x 3 $\frac{1}{8}$ " Allen Bolt (#79), two $\text{\O } \frac{3}{4}$ " Washers (#86), and one M10 Aircraft Nut (#90). Do not over tighten the Nut and Bolt. Make sure the Leg Developer is able to swivel.
- J.) Attach the Upper Vertical Frame (#15) to the Lower Vertical Frame (#4). Secure them with four M10 x 2 $\frac{3}{8}$ " Carriage Bolts (#83), two 5 $\frac{1}{2}$ " 4-Holes Brackets (#16), four $\text{\O } \frac{3}{4}$ " Washers (#86), and four M10 Aircraft Nuts (#90).
- K.) Attach the Stopper Frame (#17) to the Upper Vertical Frame. Secure it with one M10 x 2 $\frac{3}{8}$ " Allen Bolt (#78) and $\text{\O } \frac{3}{4}$ " Washer (#86).
- L.) Attach a Swivel Pulley Bracket (#20) to the bracket behind the Upper Vertical Frame (#15). Secure it with one M10 x 2 $\frac{1}{2}$ " Allen Bolt (#77), two $\text{\O } \frac{3}{4}$ " Washers (#86), and one M10 Aircraft Nut (#90). Repeat to install the other side. Do not over tighten the nuts and bolts. Make sure the Brackets are able to swivel.

DIAGRAM 1

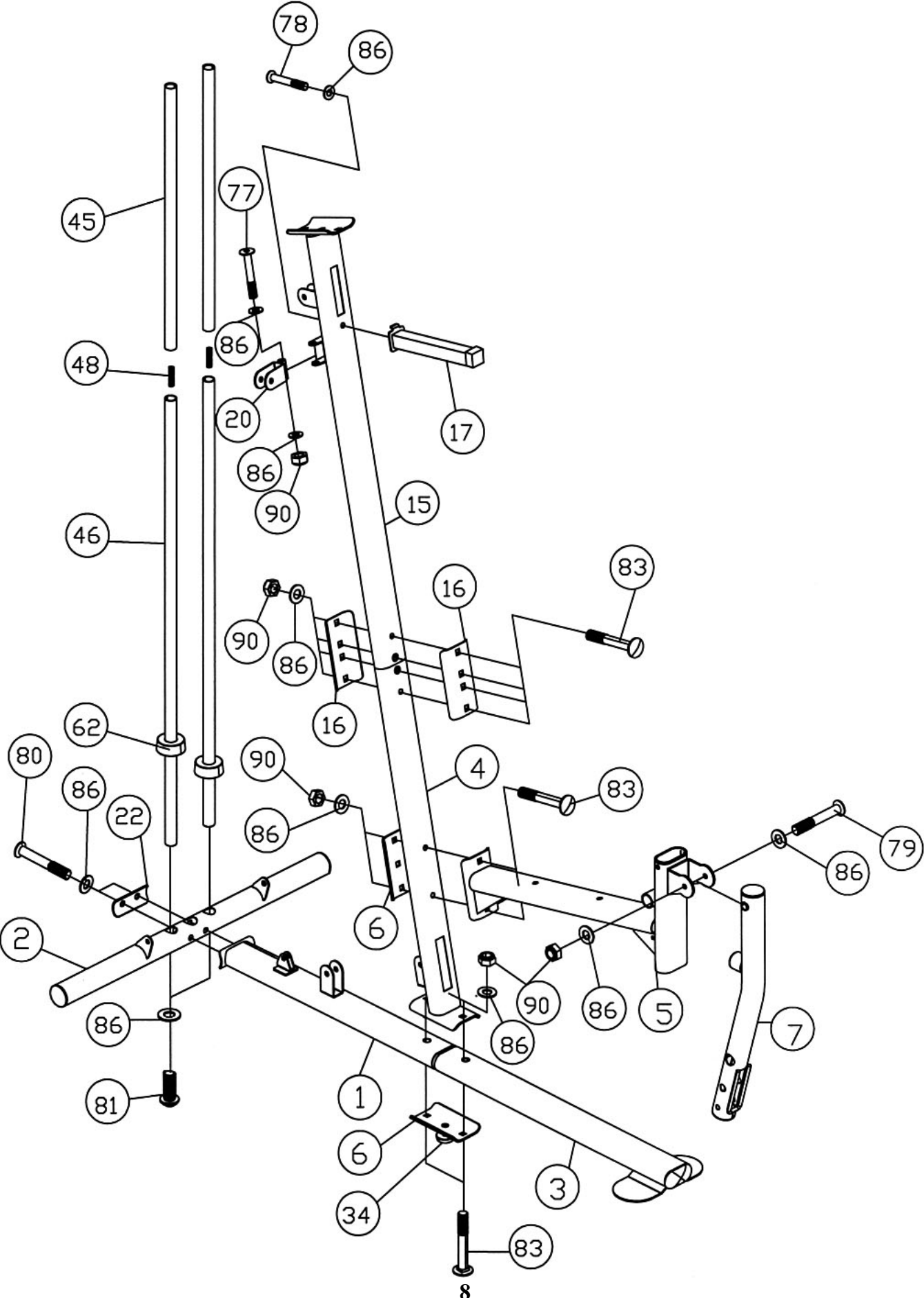

STEP 2 (See Diagram 2)

- A.) Slide 9 Weight Plates (#66) onto the Guide Rods. Make sure the grooves on the Weight Plates are all facing the back of the machine and downward. Insert the Selector Rod (#47) through the center hole on the Weight Plates.
- B.) Slide the Selector Stem (#65) onto the Guide Rods.
- C.) Slide the Ring on the Selector Pin (#67) onto the Selector Rod. Insert the Selector Pin into the selected groove to choose the number of weight plates for exercise.
Note: Each weight plate weights approximately 10 lbs.
- D.) Attach the Upper Frame (#8) onto the two Guide Rods. Secure the two Guide Rods to the Upper Frame with two M10 x 1" Allen Bolts (#81) and $\text{\O} \frac{3}{4}$ " Washers (#86).
- E.) Place the Upper Frame onto the Upper Vertical Frame (#15). Secure it with two M10 x 2 $\frac{3}{8}$ " Carriage Bolts (#83), one 5 $\frac{1}{2}$ " Curved Bracket (#6), two $\text{\O} \frac{3}{4}$ " Washers (#86), and two M10 Aircraft Nuts (#90).
- F.) Securely tighten all Nuts and Bolts previously installed.
- G.) Attach the Front Press Base (#9) to the Upper Frame. Align the holes and insert an Axle (#32) through the holes. Secure each end of the Axle with one M10 x $\frac{5}{8}$ " Allen Bolt (#82) and one $\text{\O} \frac{3}{4}$ " Washer (#86).
- H.) Place the Seat Pad (#37) onto the Seat Support (#5). Secure it with two M8 x 2 $\frac{1}{8}$ " Allen Bolts (#73) and two $\text{\O} \frac{5}{8}$ " Washers (#87).
- I.) Attach the Arm Curl Pad (#36) to the Arm Curl Stand (#19). Secure it with two M8 x $\frac{5}{8}$ " Allen Bolts (#72) and $\text{\O} \frac{5}{8}$ " Washers (#87). Insert the Arm Curl Stand into the opening on the Seat Support Frame. Use a Lock Knob (#68) to lock the Arm Curl Stand at desired height.
- J.) Insert two Foam Tubes (#44) halfway through the holes on the Leg Developer and Seat Support. Push four Foam Rolls (#56) onto the Tubes. Plug four Foam Roll End Caps (#53) into the ends.

DIAGRAM 2

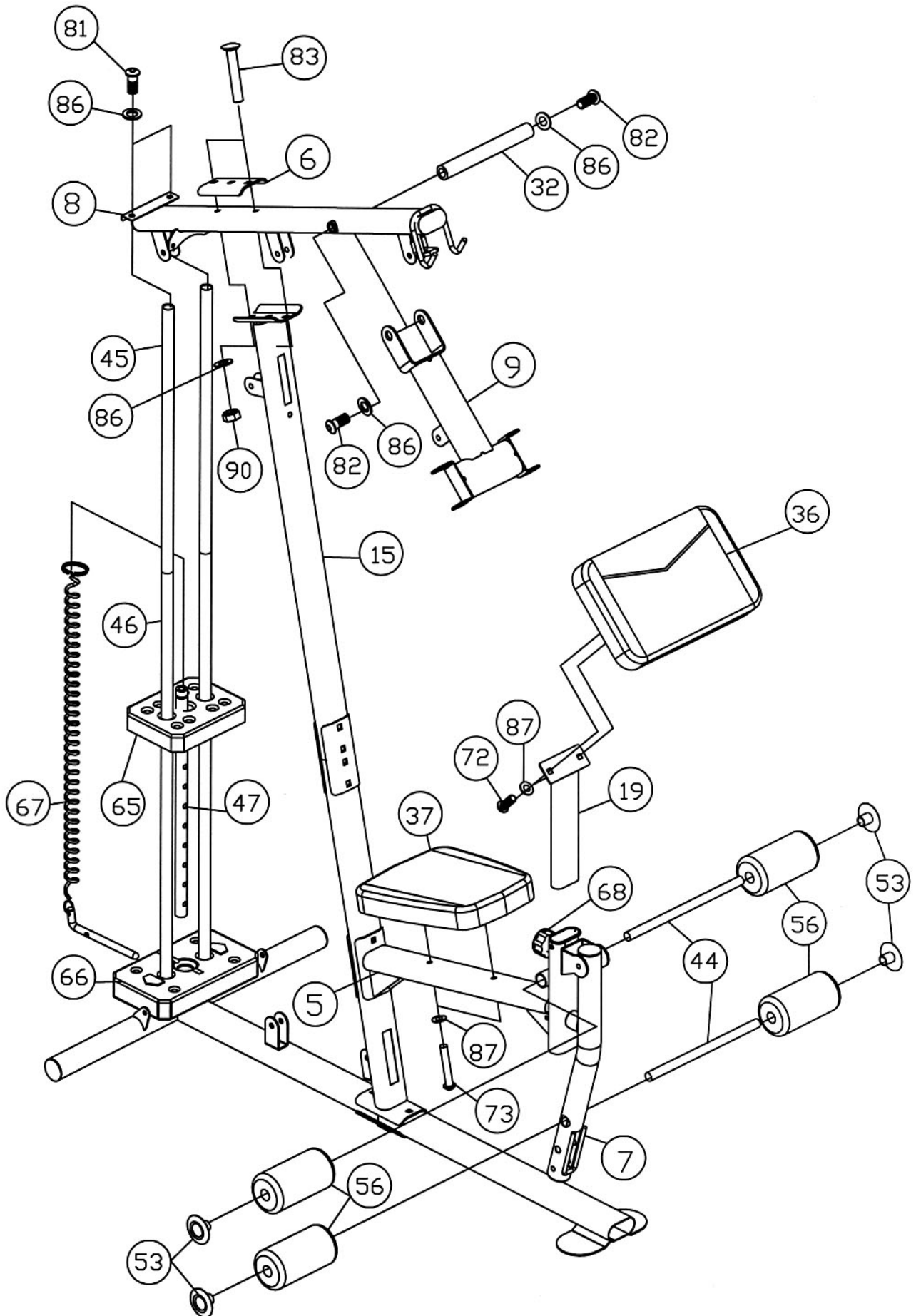

STEP 3 (See Diagram 3)

- A.) Attach the Left Butterfly (#10) to the open bracket on the Front Press Base (#9). Secure it with one M12 x 4" Hex Bolt (#84), two Ø 1" Washers (#88), and one M12 Aircraft Nut (#91).
- B.) Slide a Butterfly Foam Roll (#57) onto the Left Butterfly arm.
- C.) Repeat Steps A&B above to install the Right Butterfly (#11).
- D.) Attach two 1 ¾" Spacers (#61) to the Lower & Upper Vertical Frames (#4 & #15). Attach the Backrest Board (#38) to the Spacers. Secure it with two M8 x 2 ½" Allen Bolts (#74) and Ø 5/8" Washers (#87).
- E.) Attach the Lower Weight Stack Cover (#26) to the Main Base Frame (#1) and Rear Base Frame (#2). Secure it with three M8 x 5/8" Allen Bolts (#72) and Ø 5/8" Washers (#87).
- F.) Attach the Cover Connector (#28) to the Lower Weight Stack Cover. Secure it with four M6 x 3/8" Philips Screws (#85) and M6 Regular Nuts (#89).
- G.) Attach the Upper Weight Stack Cover (#27) to the Upper Frame (#8). Secure it with two M8 x 5/8" Allen Bolts (#72) and Ø 5/8" Washers (#87).
- H.) Secure the Upper Weight Stack Cover to the Cover Connector with four M6x 3/8" Philips Screws (#85) and M6 Regular Nuts (#89).

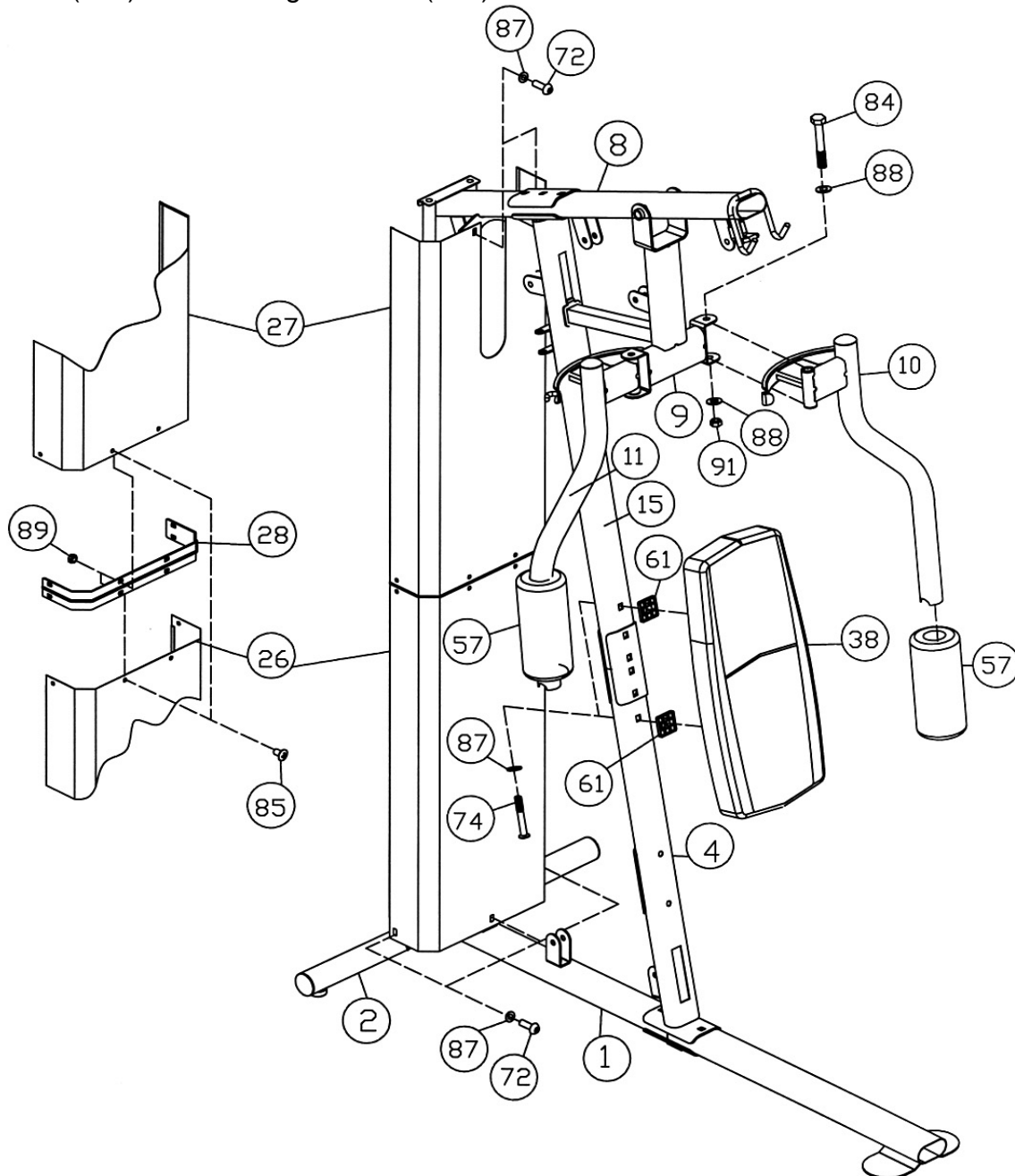

CABLE LOOP DIAGRAM

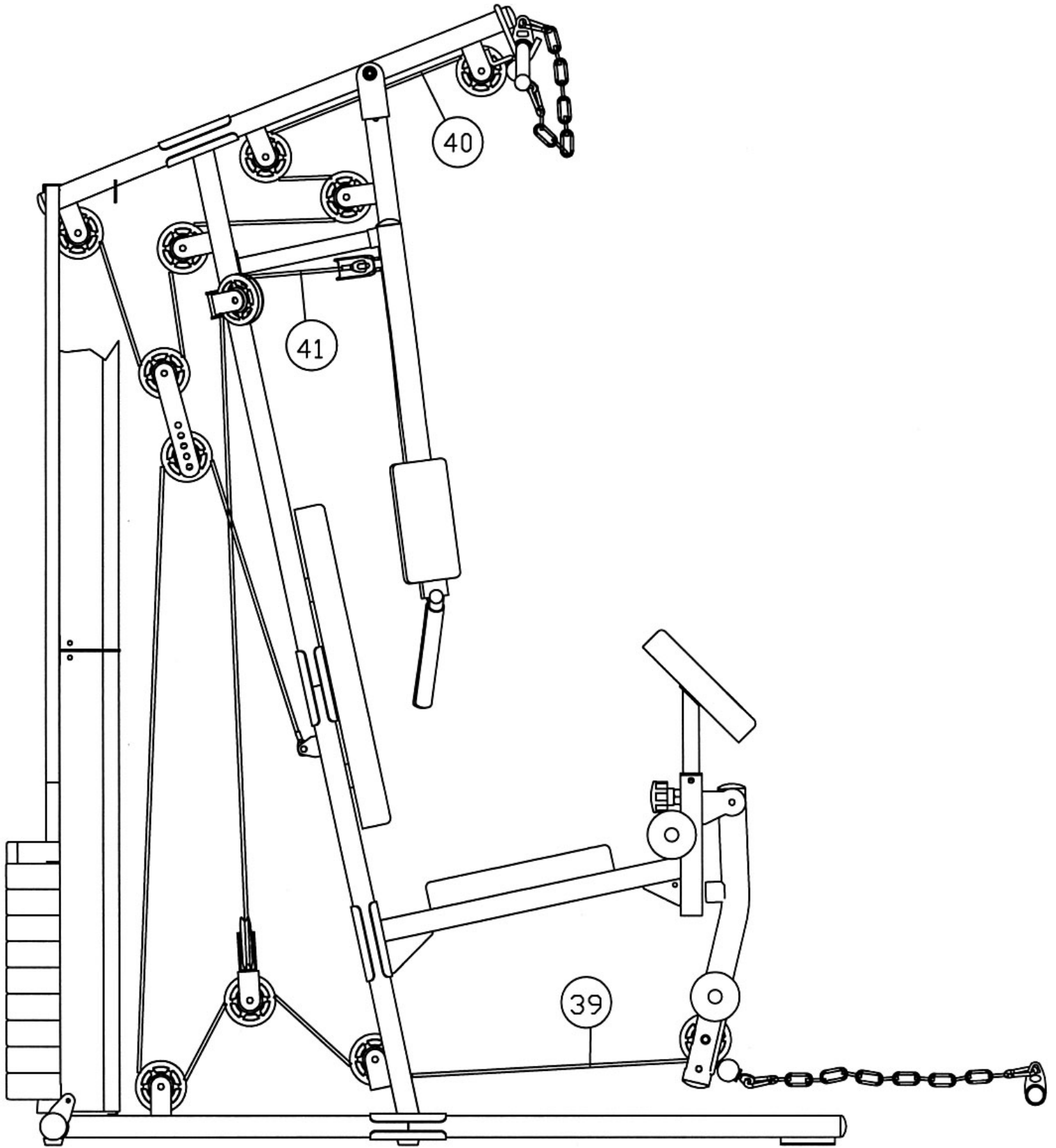

STEP 4 (See Diagram 4 & Cable Loop Diagram)

- A.) Attach the 122" Upper Cable (#40) to the open bracket underneath the front of Upper Frame (#8).
- B.) Attach a Pulley (#49) to the open bracket. Secure it with one M10 x 1 3/4" Allen Bolt (#75), two Ø 3/4" Washers (#86), and one M10 Aircraft Nut (#90). Note: The Ball Stopper on the Cable should be underneath the Frame and Pulley.
- C.) Draw the Cable towards the back of the machine to the open bracket under the Upper Frame. Repeat Procedure B above to install another Pulley.
- D.) Draw the Cable around the Pulley then pull back to the open bracket on the back of Front Press Base (#9).
- E.) Repeat Procedure B above to install another Pulley.
- F.) Draw the Cable around the Pulley then to the open bracket on the back of the Upper Vertical Frame (#15). Repeat Procedure B above to install another Pulley.
- G.) Draw the Cable around the Pulley then downward. Attach the Cable to two Double Floating Pulley Brackets (#43). Install another Pulley. Let the bracket hanging for now.
- H.) Pull the Cable around the Pulley then upward to the open bracket underneath the Upper Frame between the two Guide Rods. Install a Pulley to the bracket.
- I.) Pull the Cable downward between the two Guide Rods to the Selector Rod (#47). Fully thread the bolt at the end of the Cable into the top opening on the Selector Rod.
- J.) Connect the Lat Bar (#21) to a Short Chain (#64) with a C-clip (#70). Then connect the Short Chain to the Upper Cable with another C-clip.
- K.) Attach the Left Front Press Handle (#12) to the Left Butterfly (#10). Secure it with one M10 x 2 1/8" Allen Bolt (#76) and Ø 3/4" Washer (#86). Repeat the same procedure to install the other side. Make sure the Handles are pointing toward the back of the machine.

DIAGRAM 4

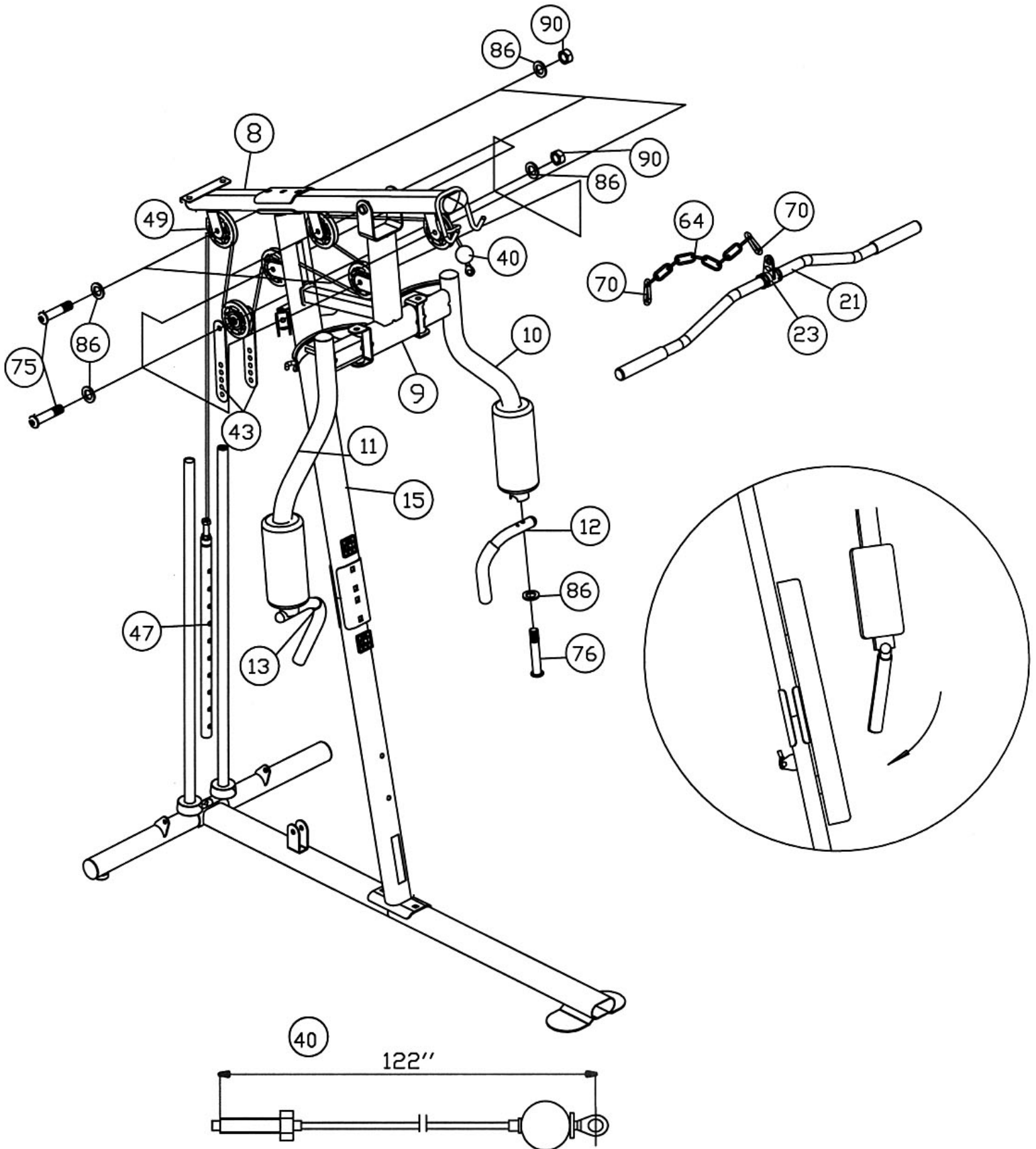

STEP 5 (See Diagram 5 & Cable Loop Diagram)

- A.) Attach one end of the 119" Butterfly Cable (#41) to the hook on the Right Butterfly (#11).
- B.) Draw the Cable to the right open bracket on the back of Upper Vertical Frame (#15).
- C.) Attach a Pulley to the bracket. Secure it with one M10 x 1 3/4" Allen Bolt (#75), two Ø 3/4" Washers (#86), and one M10 Aircraft Nut (#90).
- D.) Draw the Cable over the Pulley then downward. Attach the Cable to a Crossed Double Floating Pulley Bracket (#14). Install a Pulley. Let the Bracket hanging for now.
- E.) Pull the Cable around the Pulley then upward to the left open bracket on the back of Upper Vertical Frame. Install a Pulley.
- F.) Draw the Cable to the Left Butterfly (#10). Attach the end to the hook on the Left Butterfly.

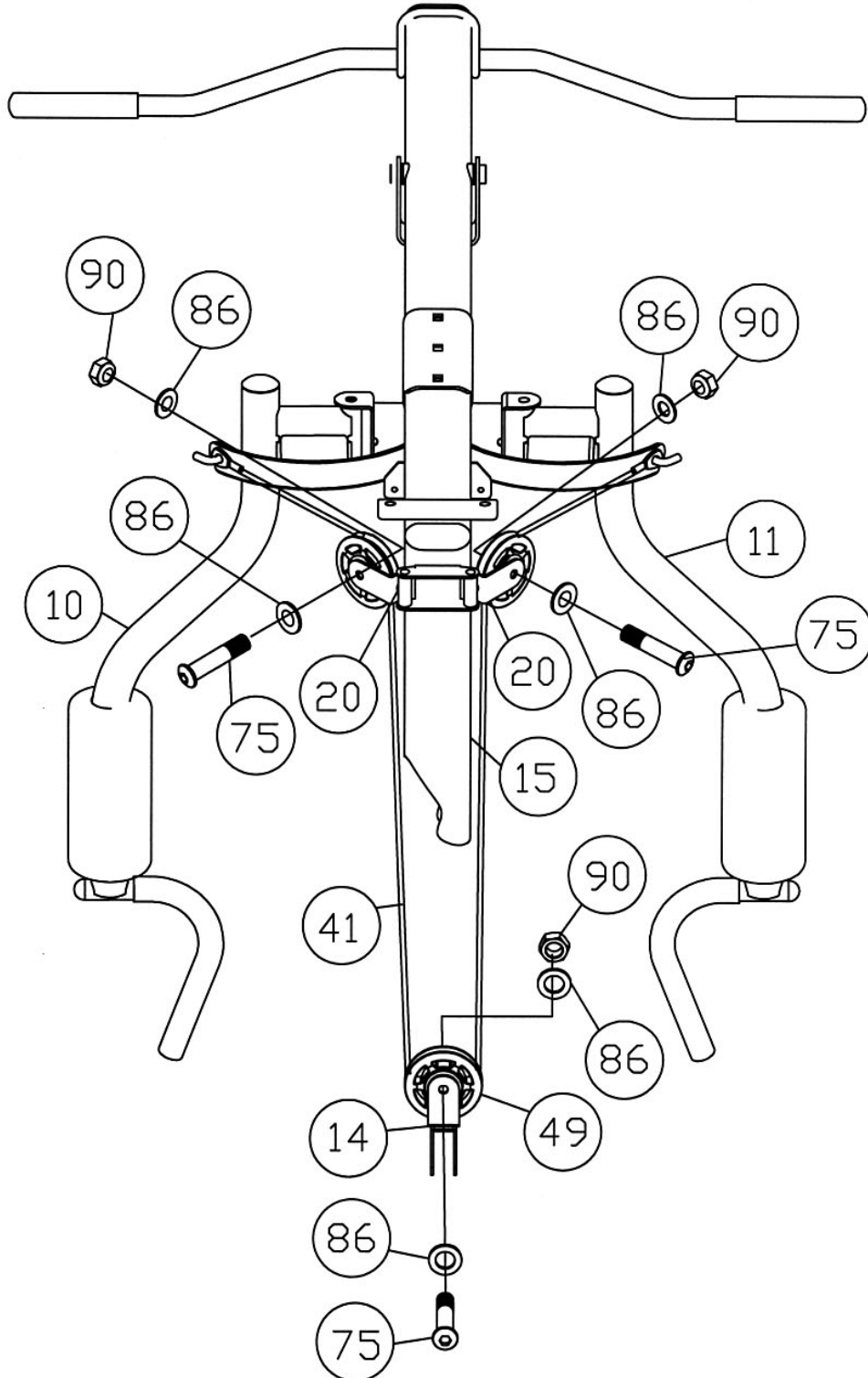

STEP 6 (See Diagram 6 & Cable Loop Diagram)

- A.) Attach the 130" Lower Cable (#39) to the opening on the bottom of the Leg Developer (#7).
- B.) Attach a Pulley (#49) to the opening. Secure it with one M10 x 2 ½" Allen Bolt (#77), two Pulley Bushings (#33), and one M10 Aircraft Nut (#90).
- C.) Draw the Cable underneath the Pulley through the opening on the Lower Vertical Frame (#4) to the open bracket on the back.
- D.) Attach a Pulley to the open bracket. Secure it with one M10 x 1 ¾" Allen Bolt (#75), two Ø ¾" Washers (#86), and one M10 Aircraft Nut (#90).
- E.) Pull the Cable upward to the Crossed Double Floating Pulley Bracket (#14) previously installed in Step-5. Install another Pulley.
- F.) Draw the Cable over the Pulley then downward to the open bracket on the Main Base Frame. Install a Pulley.
- G.) Pull the Cable around the Pulley then upward to the Double Floating Pulley Brackets (#43) previously installed in Step-4. Install a Pulley.
- H.) Draw the Cable around the Pulley then pull downward to the triangle bracket on the back of the Lower Vertical Frame (#4). Secure the Cable to the bracket with one M10 x 1" Allen Bolt (#81), two Ø ¾" Washers (#86), and one M10 Aircraft Nut (#90).
- I.) Adjust the tension of the Cable by adjusting the Pulley position on the Double Floating Pulley Bracket (#43). If the cables are too loose, move up the Pulley. If the cables are too tight, move down the Pulley.
- J.) For best performance of the machine, adjust the Cables so the Selector Stem (Top Plate) on the weight stack is ¼" above the first plate. While pinning the weight stack, push down on the Selector Stem to close up the gap then pin the plates. This will remove the slag in the cable system so the range of motion is smooth and tight.
- K.) Connect the Shiver Bar (#24) to a Long Chain (#63) with a C-clip (#70). Connect the Long Chain to the Lower Cable with another C-clip.

DIAGRAM 6

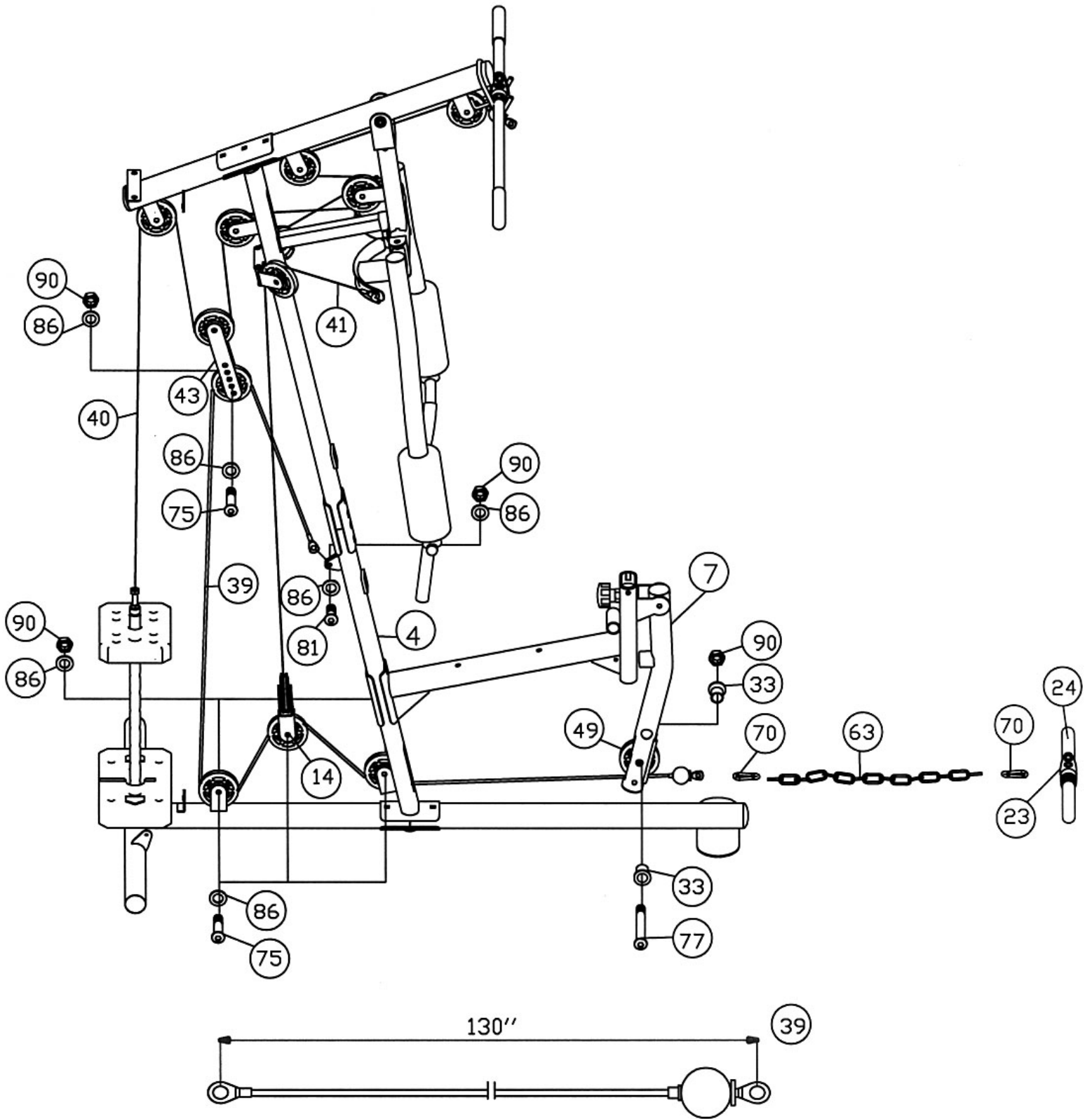

EXPLODED DIAGRAM

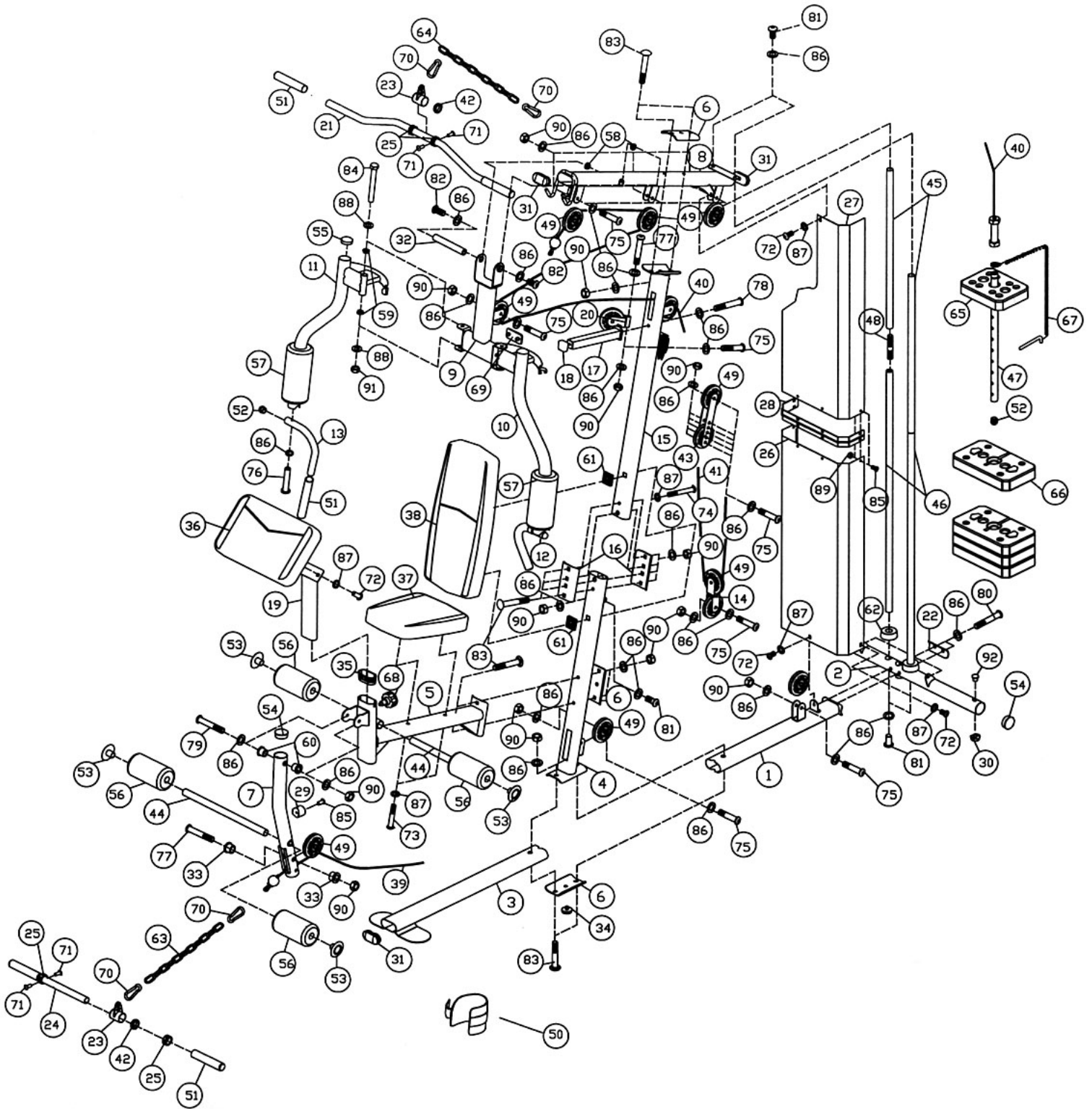

PARTS LIST

KEY NO. DESCRIPTION

Q'ty

KEY NO.	DESCRIPTION	Q'ty			
1	Main Base Frame	1	51	Handle Grip	6
2	Rear Base Frame	1	52	Ø 1" Con-shaped End Cap	3
3	Front Base Frame	1	53	Foam Roll End Cap	4
4	Lower Vertical Frame	1	54	Ø 2" End Cap	4
5	Seat Support	1	55	Ø 1 ¾" End Cap	2
6	5 ½" Curved Bracket	3	56	Foam Roll	4
7	Leg Developer	1	57	Butterfly Foam Roll	2
8	Upper Frame	1	58	Ø 1" x Ø 5/8" Bushing	2
9	Front Press Base	1	59	Ø 1" x Ø ½" Bushing	4
10	Left Butterfly	1	60	Ø ¾" x Ø ½" Bushing	2
11	Right Butterfly	1	61	1 ¾" Spacer	2
12	Left Front Press Handle	1	62	Ø 2 ½" x 1" Rubber Bumper	2
13	Right Front Press Handle	1	63	Long Chain	1
14	Crossed Double Floating Pulley Bracket	1	64	Short Chain	1
15	Upper Vertical Frame	1	65	Selector Stem	1
16	5 ½" 4-Holes Bracket	2	66	Weight Plate	9
17	Stopper Frame	1	67	Selector Pin	1
18	1 1/8" Stopper Frame End Cap	1	68	Lock Knob	1
19	Arm Curl Stand	1	69	1 ½" x 3" Rubber Bumper	1
20	Swivel Pulley Bracket	2	70	C-clip	4
21	Lat Bar	1	71	Rivet	8
22	4" Curved Bracket	1	72	M8 x 5/8" Allen Bolt	7
23	Bar Handle	2	73	M8 x 2 1/8" Allen Bolt	2
24	Shiver Bar	1	74	M8 x 2 ½" Allen Bolt	2
25	Plastic Ring	4	75	M10 x 1 ¾" Allen Bolt	13
26	Lower Weight Stack Cover	1	76	M10 x 2 1/8" Allen Bolt	2
27	Upper Weight Stack Cover	1	77	M10 x 2 ½" Allen Bolt	3
28	Cover Connector	1	78	M10 x 2 3/8" Allen Bolt	1
29	Ø 1 ½" Leg Developer Rubber Bumper	1	79	M10 x 3 1/8" Allen Bolt	1
30	Ø 1 3/8" x ¾" Floor Spacer	3	80	M10 x 2 ¾" Allen Bolt	2
31	3 1/8" End Cap	3	81	M10 x 1" Allen Bolt	5
32	Axle	1	82	M10 x 5/8" Allen Bolt	2
33	Pulley Bushing	2	83	M10 x 2 3/8" Carriage Bolt	10
34	Ø 1 5/8" x 7/8" Floor Spacer	1	84	M12 x 4" Hex Bolt	2
35	3 1/8" Sleeve	1	85	M6 x 3/8" Philips Screw	9
36	Arm Curl Pad	1	86	Ø ¾" Washer	55
37	Seat Pad	1	87	Ø 5/8" Washer	11
38	Backrest Board	1	88	Ø 1" Washer	4
39	130" Lower Cable	1	89	M6 Regular Nut	8
40	122" Upper Cable	1	90	M10 Aircraft Nut	28
41	119" Butterfly Cable	1	91	M12 Aircraft Nut	2
42	Handle Bushing	4	92	Ø 5/8" End Cap	1
43	Double Floating Pulley Bracket	2		#5 Allen Wrench (Tool)	1
44	Foam Tube	2		#6 Allen Wrench (Tool)	1
45	Upper Guide Rod	2			
46	Lower Guide Rod	2			
47	Selector Rod	1			
48	M10 Stud Bolt	2			
49	Pulley	14			
50	Ankle Strap	1			

WM-1509 WEIGHT RESISTANCE CHART

	WEIGHT PLATE								
Station	1	2	3	4	5	6	7	8	9
Front Press	30	42	54	66	78	90	102	114	126
Butterfly	15	20	25	30	35	40	45	50	55
Lat Pull	30	40	50	60	70	80	90	100	110
Low Pulley	30	40	50	60	70	80	90	100	110
Leg Developer	30	40	50	60	70	80	90	100	110

*** Each plate weights approximately 10 lbs.**

***Numbers are approximate. Actual weight may vary.**

***Value for butterfly is for each arm.**

IMPEX[®] INC.

LIMITED WARRANTY

IMPEX Inc. ("IMPEX[®]") warrants this product to be free from defects in workmanship and material, under normal use and service conditions, for a period of two years on the Frame from the date of purchase. This warranty extends only to the original purchaser. IMPEX's obligation under this Warranty is limited to replacing or repairing, at IMPEX's option.

All returns must be pre-authorized by IMPEX. Pre-authorization may be obtained by calling IMPEX Customer Service Department at 1-800-999-8899. All freights on products returned to IMPEX must be prepaid by the customer. This warranty does not extend to any product or damage to a product caused by or attributable to freight damage, abuse, misuse, improper or abnormal usage or repairs not provided by an IMPEX authorized service center or for products used for commercial or rental purposes. No other warranty beyond that specifically set forth above is authorized by IMPEX.

IMPEX is not responsible or liable for indirect, special or consequential damages arising out of or in connection with the use or performance of the product or other damages with respect to any economic loss, loss of property, loss of revenues or profits, loss of enjoyments or use, costs of removal, installation or other consequential damages or whatsoever natures. Some states do not allow the exclusion or limitation of incidental or consequential damages. Accordingly, the above limitation may not apply to you.

The warranty extended hereunder is in lieu of any and all other warranties and any implied warranties of merchantability or fitness for a particular purpose is limited in its scope and duration to the terms set forth herein. Some states do not allow limitations on how long an implied warranty lasts. Accordingly, the above limitation may not apply to you.

This warranty gives you specific legal right. You may also have other rights which vary from state to state. Register on-line at www.impex-fitness.com

IMPEX[®] INC.
14777 Don Julian
City of Industry, CA 91746

ORDERING REPLACEMENT PARTS

Replacement parts can be ordered by calling our Customer Service Department toll-free at **1-800-999-8899** during our regular business hours: Monday through Friday, 9 am until 5 pm Pacific standard time.

info@impex-fitness.com

When ordering replacement parts, always give the following information.

1. Model
2. Description of Parts
3. Part Number
4. Date of Purchase