

NOTE:  
Please read all instructions  
carefully before using this  
product

Table of Contents

Safety Notice

Hardware Pack

Assembly Instruction

Parts List

Resistance Chart

Warranty

Ordering Parts

Model  
MWM-1840

Retain This  
Manual for  
Reference

101015

OWNER'S  
MANUAL

**IMPEX**  
FITNESS PRODUCTS

## MARCY<sup>®</sup> MWM-1840 HOME GYM

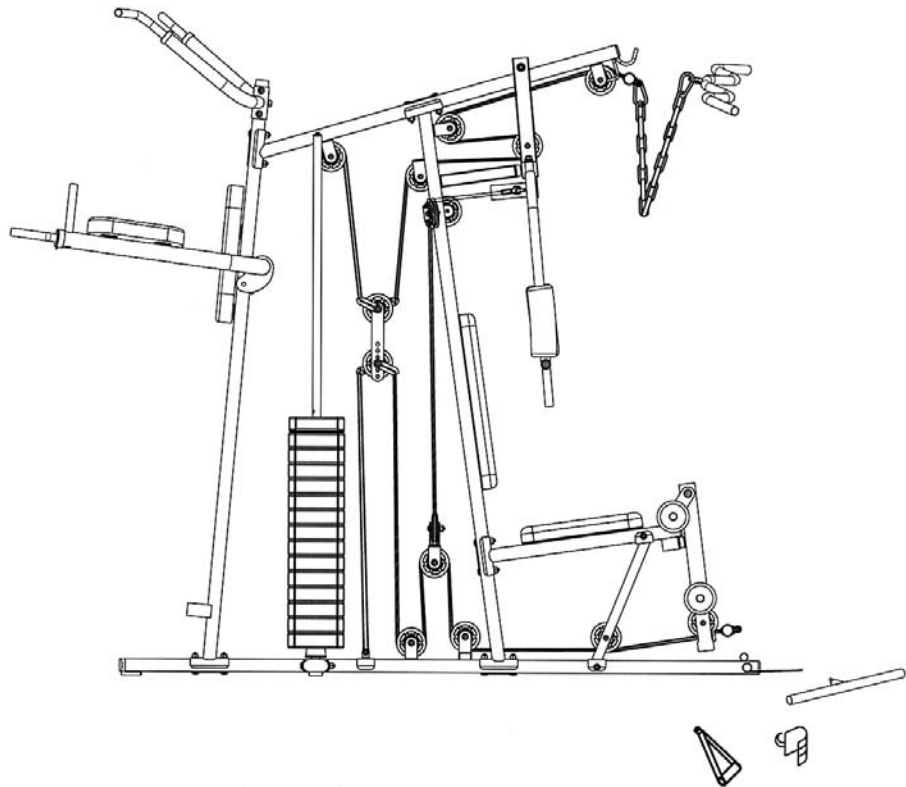

**IMPEX<sup>®</sup> INC.**

14777 DON JULIAN RD., CITY OF INDUSTRY, CA 91746

Tel: (800) 999-8899 Fax: (626) 961-9966

**[www.impex-fitness.com](http://www.impex-fitness.com)**

**[info@impex-fitness.com](mailto:info@impex-fitness.com)**

---

## TABLE OF CONTENTS

BEFORE YOU BEGIN.....	1
IMPORTANT SAFETY NOTICES.....	2
HARDWARE IDENTIFIER.....	4
ASSEMBLY INSTRUCTIONS.....	7
PARTS LIST.....	26
RESISTANCE CHART.....	27
WARRANTY.....	28
ORDERING PARTS.....	28

---

## BEFORE YOU BEGIN

Thank you for selecting the MARCY MWM-1840 HOME GYM by IMPEX<sup>®</sup> INC. For your safety and benefit, read this manual carefully before using the machine. As a manufacturer, we are committed to provide you complete customer satisfaction. If you have any questions, or find there are missing or damaged parts, we guarantee you complete satisfaction through direct assistance from our factory. To avoid unnecessary delays, *please call our TOLL-FREE customer service number*. Our Customer Service Agents will provide immediate assistance to you.

**Toll-Free Customer Service Number**

**1-800-999-8899**

**Mon. – Fri. 9 a.m. – 5 p.m. PST**

**[www.impex-fitness.com](http://www.impex-fitness.com)**

**[info@impex-fitness.com](mailto:info@impex-fitness.com)**

## **IMPORTANT SAFETY NOTICE**

### **PRECAUTIONS**

This exercise machine is built for optimum safety. However, certain precautions apply whenever you operate a piece of exercise equipment. Be sure to read the entire manual before you assemble or operate your machine. In particular, note the following safety precautions:

1. **Keep children and pets away from the machine at all times. DO NOT leave children unattended in the same room with the machine.**
2. Only one person at a time should use the machine.
3. If the user experiences dizziness, nausea, chest pain, or any other abnormal symptoms, STOP the workout at once. CONSULT A PHYSICIAN IMMEDIATELY.
4. Position the machine on a clear, leveled surface. DO NOT use the machine near water or outdoors.
5. Keep hands away from all moving parts.
6. Always wear appropriate workout clothing when exercising. DO NOT wear robes or other clothing that could become caught in the machine. Running or aerobic shoes are also required when using the machine.
7. Use the machine only for its intended use as described in this manual. DO NOT use attachments not recommended by the manufacturer.
8. Do not place any sharp object around the machine.
9. Disabled person should not use the machine without a qualified person or physician in attendance.
10. Before using the machine to exercise, always do stretching exercises to properly warm up.
11. Never operate the machine if the machine is not functioning properly.
12. A spotter is recommended during exercise.
13. Do not intend to insert weight selector pin while the weight stack or top plate is in elevated position.
14. Be certain the weight Selector Pin is completely inserted.
15. Never use dumbbells or other means to increase the weight resistance. Use only weight plates provided by manufacturer.
16. This machine is designed and intended for home and consumer use only, not for commercial use.

### **CARE AND MAINTENANCE**

1. Lubricate moving parts with WD-40 or light oil periodically.
2. Inspect and tighten all parts before using the machine.
3. The machine can be cleaned using a damp cloth and mild non-abrasive detergent. DO NOT use solvents.
4. Maximum user's weight: 300 lbs.
5. Assembled Dimension: 96" x 38" x 83"

**WARNING: BEFORE BEGINNING ANY EXERCISE PROGRAM, CONSULT YOUR PHYSICIAN. THIS IS ESPECIALLY IMPORTANT FOR INDIVIDUALS OVER THE AGE OF 35 OR PERSONS WITH PRE-EXISTING HEALTH PROBLEMS. READ ALL INSTRUCTIONS BEFORE USING ANY FITNESS EQUIPMENT. IMPEX INC. ASSUMES NO RESPONSIBILITY FOR PERSONAL INJURY OR PROPERTY DAMAGE SUSTAINED BY OR THROUGH THE USE OF THIS PRODUCT.**

**SAVE THESE INSTRUCTIONS.**

# WARNING LABEL PLACEMENT

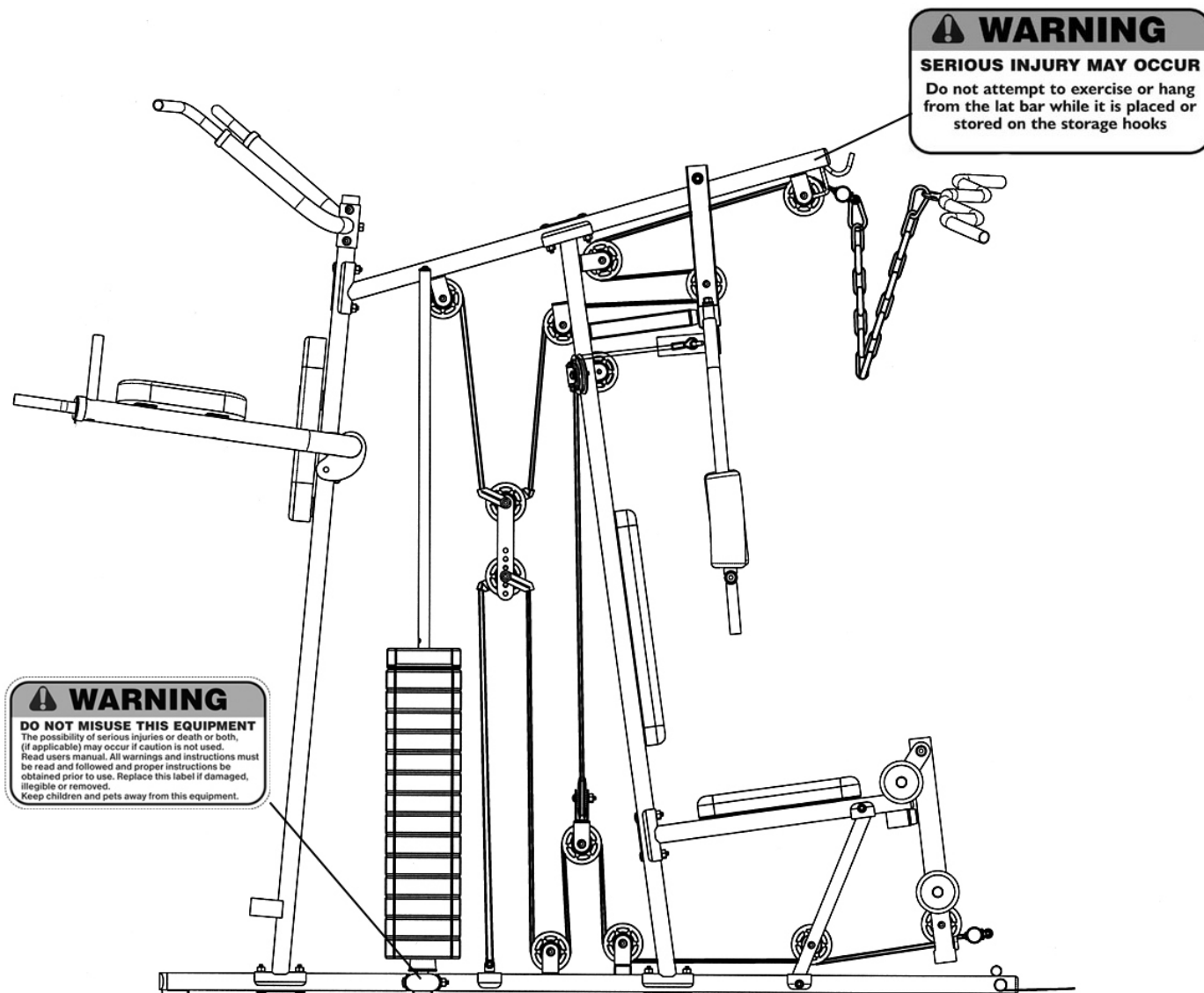

The warning labels shown here have been placed on the Middle Stabilizer and Upper Frame. If the labels are missing or illegible, please call customer service at 1-800-888-8899 for replacements. Apply the labels in the location shown.

# HARDWARE PACK

NOTE: The following parts are not drawn to scale. Please use your own ruler to measure the size.

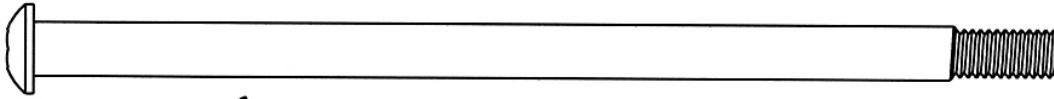

#73 M10 x 7 1/2" Allen Bolt (Qty 1)

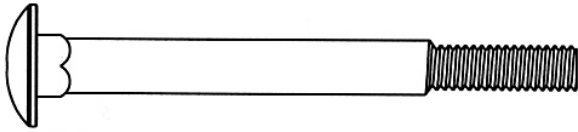

#71 M10 x 4" Carriage Bolt (Qty 2)

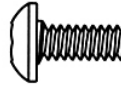

#78 M8 x 5/8" Allen Bolt (Qty 4)

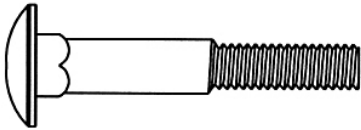

#72 M10 x 2 3/8" Carriage Bolt (Qty 10)

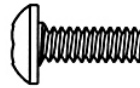

#80 M8 x 3/4" Allen Bolt (Qty 2)

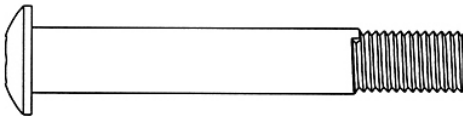

#77 M12 x 3 1/8" Allen Bolt (Qty 1)

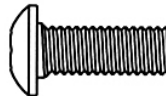

#81 M10 x 1" Allen Bolt (Qty 11)

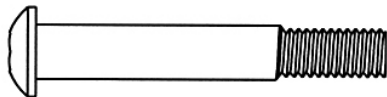

#76 M10 x 2 1/2" Allen Bolt (Qty 6)



#79 M8 x 2 1/8" Allen Bolt (Qty 2)

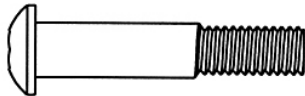

#75 M10 x 2" Allen Bolt (Qty 2)



#93 Ø 5/8" x 1/2" Curved Washer (Qty 2)

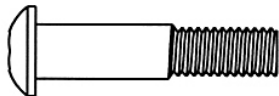

#74 M10 x 1 3/4" Allen Bolt (Qty 10)



#52 Ø 1" x 5/8" Pulley Bushing (Qty 4)

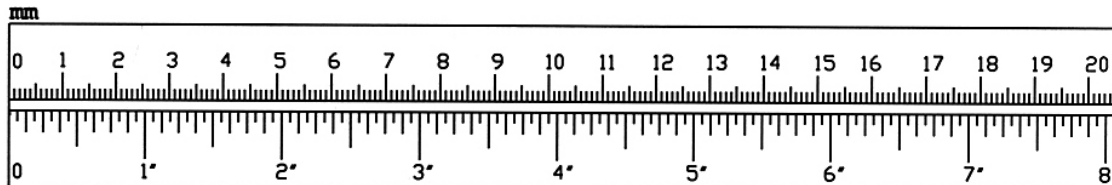

# HARDWARE PACK

NOTE: The following parts are not drawn to scale. Please use your own ruler to measure the size.

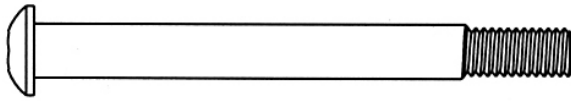

#83 M10 x 4" Allen Bolt (Qty 2)

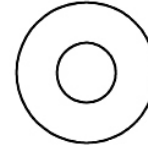

#96 Ø 1" Large Washer (Qty 4)

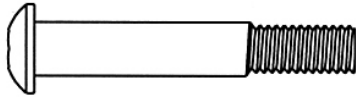

#82 M10 x 2  $\frac{3}{8}$ " Allen Bolt (Qty 1)

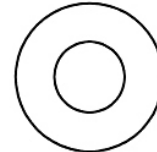

#92 Ø 1" Washer (Qty 3)

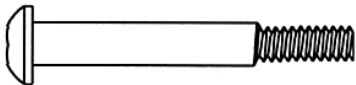

#85 M8 x 2  $\frac{3}{8}$ " Allen Bolt (Qty 2)



#90 Ø  $\frac{5}{8}$ " Washer (Qty 8)

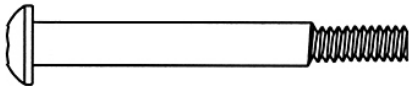

#84 M8 x 2  $\frac{3}{4}$ " Allen Bolt (Qty 4)

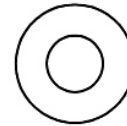

#91 Ø  $\frac{3}{4}$ " Washer (Qty 59)

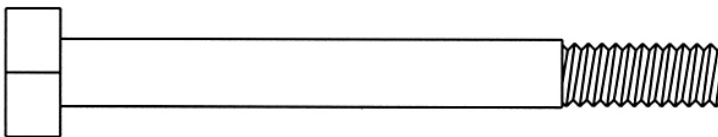

#86 M10 x 4  $\frac{7}{8}$ " Hex Bolt (Qty 1)



#95 Ø  $\frac{3}{4}$ " x 1  $\frac{1}{8}$ " Curved Washer (Qty 4)



#97 M10 Aircraft Nut (Qty 40)

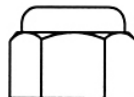

#98 M12 Aircraft Nut (Qty 1)



#94 Ø  $\frac{5}{8}$ " x 1" Curved Washer (Qty 4)

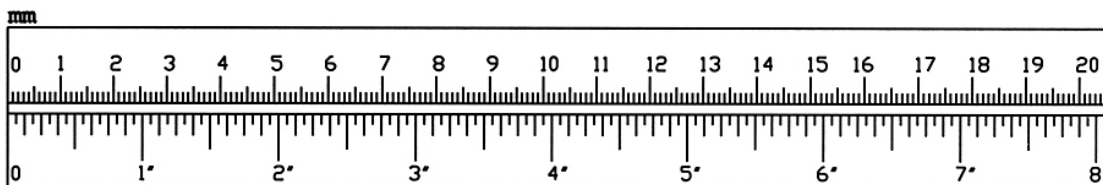

# HARDWARE PACK

NOTE: The following parts are not drawn to scale. Please use your own ruler to measure the size.

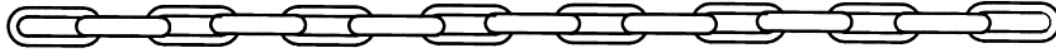

#55 15-link Chain (Qty 1)

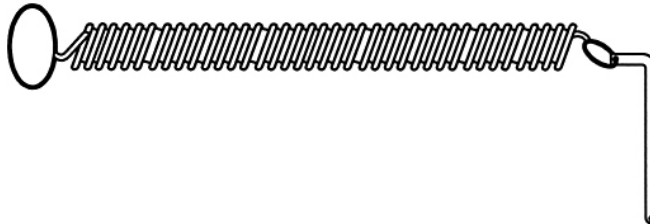

#64 Weight Selector Pin (Qty 1)

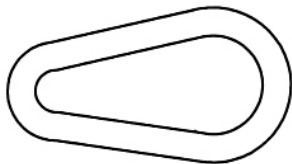

#63 Hook (Qty 2)

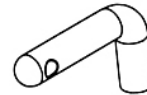

#54 Weight Plate Lock Pin (Qty 1)

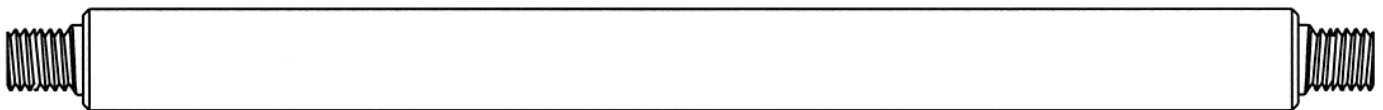

#19 8 1/2" Front Press Axle (Qty 1)

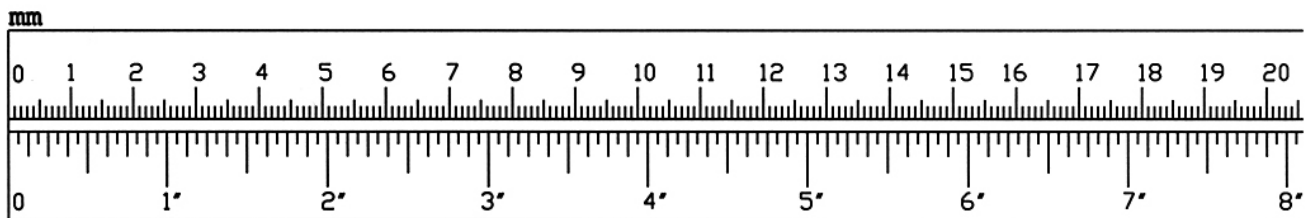

# ASSEMBLY INSTRUCTION

Tools Required for Assembling the Machine: Two Adjustable Wrenches and Allen Wrenches. NOTE: It is strongly recommended that this machine to be assembled by two or more people to avoid possible injury.

## STEP 1 (See Diagram 1)

- A.) Place the Middle Stabilizer (#2) on flat surface.
- B.) Attach the Base Frame (#3) to the front of Middle Stabilizer. Attach the Rear Stabilizer (#20) to the Middle Stabilizer from rear.
- C.) Align the holes. Secure them together with two M10 x 4" Carriage Bolts (#71), two  $\text{\O} \frac{3}{4}$ " Washers (#91), and two M10 Aircraft Nuts (#97).

**DIAGRAM 1**

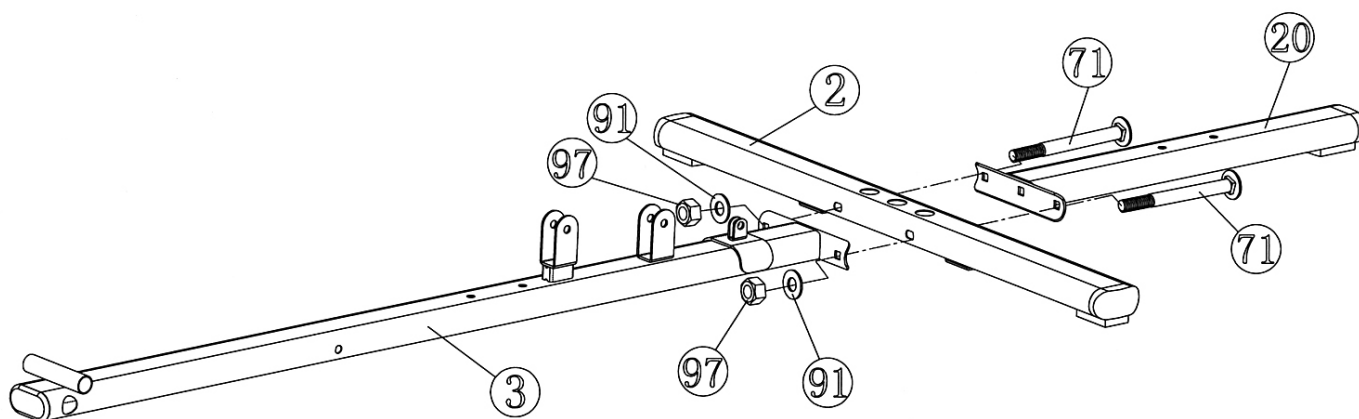



## STEP 2 (See Diagram 2)

- A.) Insert the two Guide Rods (#11) into the holes on the Middle Stabilizer (#2). Secure each Guide Rod with one M10 x 1" Allen Bolt (#81) and two  $\varnothing \frac{3}{4}$ " Washers (#91) from the bottom. Slide two  $\varnothing 2 \frac{1}{4}$ " x 1" Guide Rod Rubber Bumpers (#39) onto the two Guide Rods from top to bottom.
- B.) **Do not tighten all Nuts and Bolts starting from this procedure until instructed to do so.**
- C.) Attach the Power Station Vertical Frame (#26) to the Rear Stabilizer (#20). Secure them with two M10 x 2  $\frac{3}{8}$ " Carriage Bolts (#72), one 4  $\frac{3}{4}$ " x 3  $\frac{1}{2}$ " Bracket (#18), two  $\varnothing \frac{3}{4}$ " Washers (#91), and two M10 Aircraft Nuts (#97).
- D.) Attach the Vertical Frame (#4) onto the Base Frame (#3). Secure them with two M10 x 2  $\frac{3}{8}$ " Carriage Bolts (#72), one 4  $\frac{3}{4}$ " x 3  $\frac{1}{2}$ " Bracket (#18), two  $\varnothing \frac{3}{4}$ " Washers (#91), and two M10 Aircraft Nuts (#97).
- E.) Attach the Vertical Seat Support (#5) to the Base Frame. Secure it with two M10 x 1" Allen Bolts (#81) and two  $\varnothing \frac{3}{4}$ " Washers (#91).
- F.) Attach the Seat Support (#6) to the Vertical Frame. Secure it with two M10 x 2  $\frac{3}{8}$ " Carriage Bolts (#72), one 4  $\frac{3}{4}$ " x 3  $\frac{1}{2}$ " Bracket (#18), two  $\varnothing \frac{3}{4}$ " Washers (#91), and two M10 Aircraft Nuts (#97).
- G.) Attach the Seat Support to the Vertical Seat Support. Secure it with M10 x 1" Allen Bolts (#81) and two  $\varnothing \frac{3}{4}$ " Washers (#91).

DIAGRAM 2

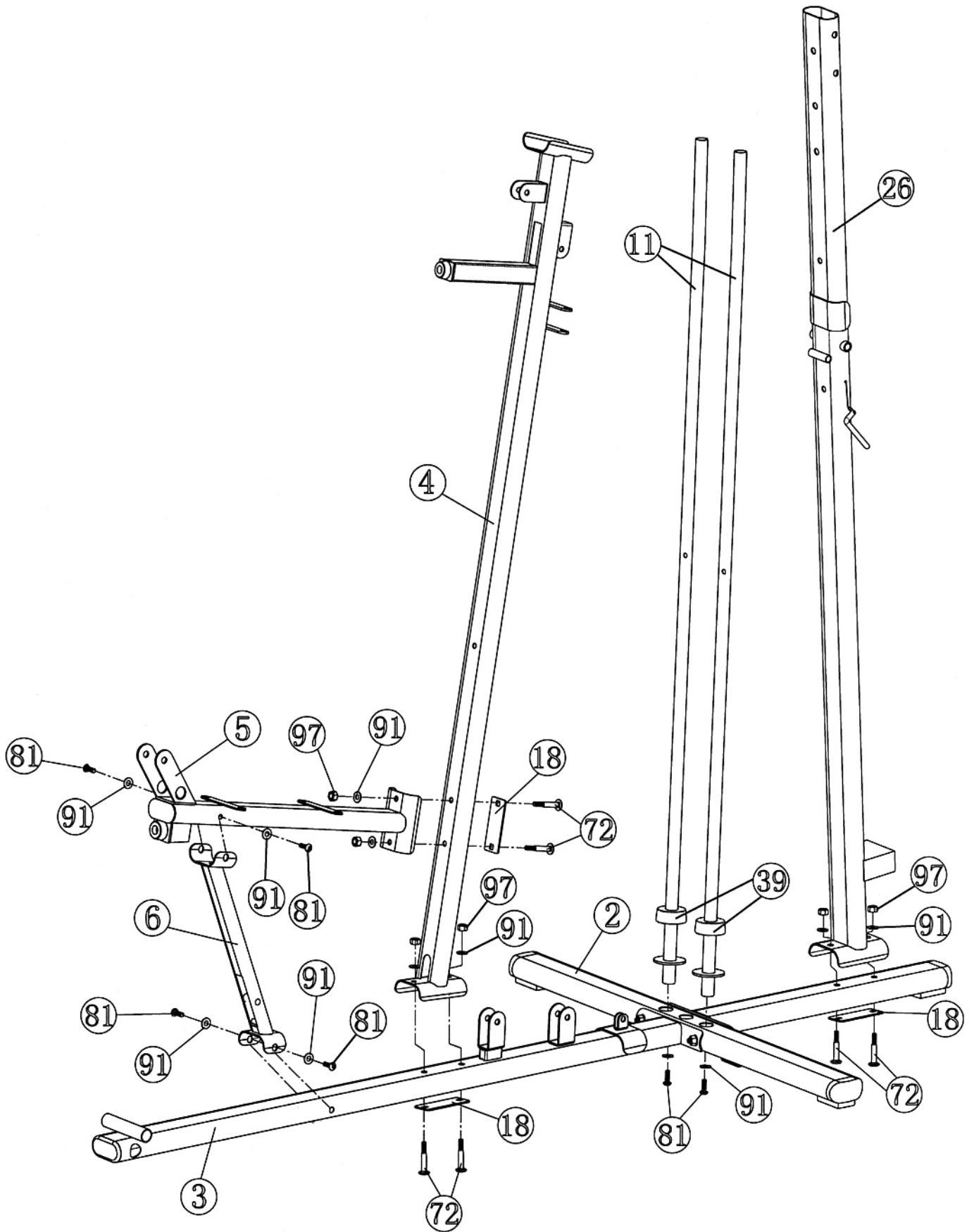

### STEP 3 (See Diagram 3)

- A.) Slide 14 Weight Plates (#42) onto the Guide Rods (#11). **Make sure the deep grooves on the Weight Plates all face the back of the machine and downward.**
- B.) Align the holes on the Weight Plates. Insert a Selector Rod (#21) through the center hole. Slide the Selector Stem (#41) onto the Guide Rods.
- C.) Use the Weight Selector Pin (#64) to select the number of Weight Plates to exercise. Attach the ring on Weight Selector Pin's cable onto the Selector Rod.
- D.) **Note: Each Weight Plate weights approximately 10 lbs. Please refer to the Weight Resistance Chart in page 27.**

### DIAGRAM 3

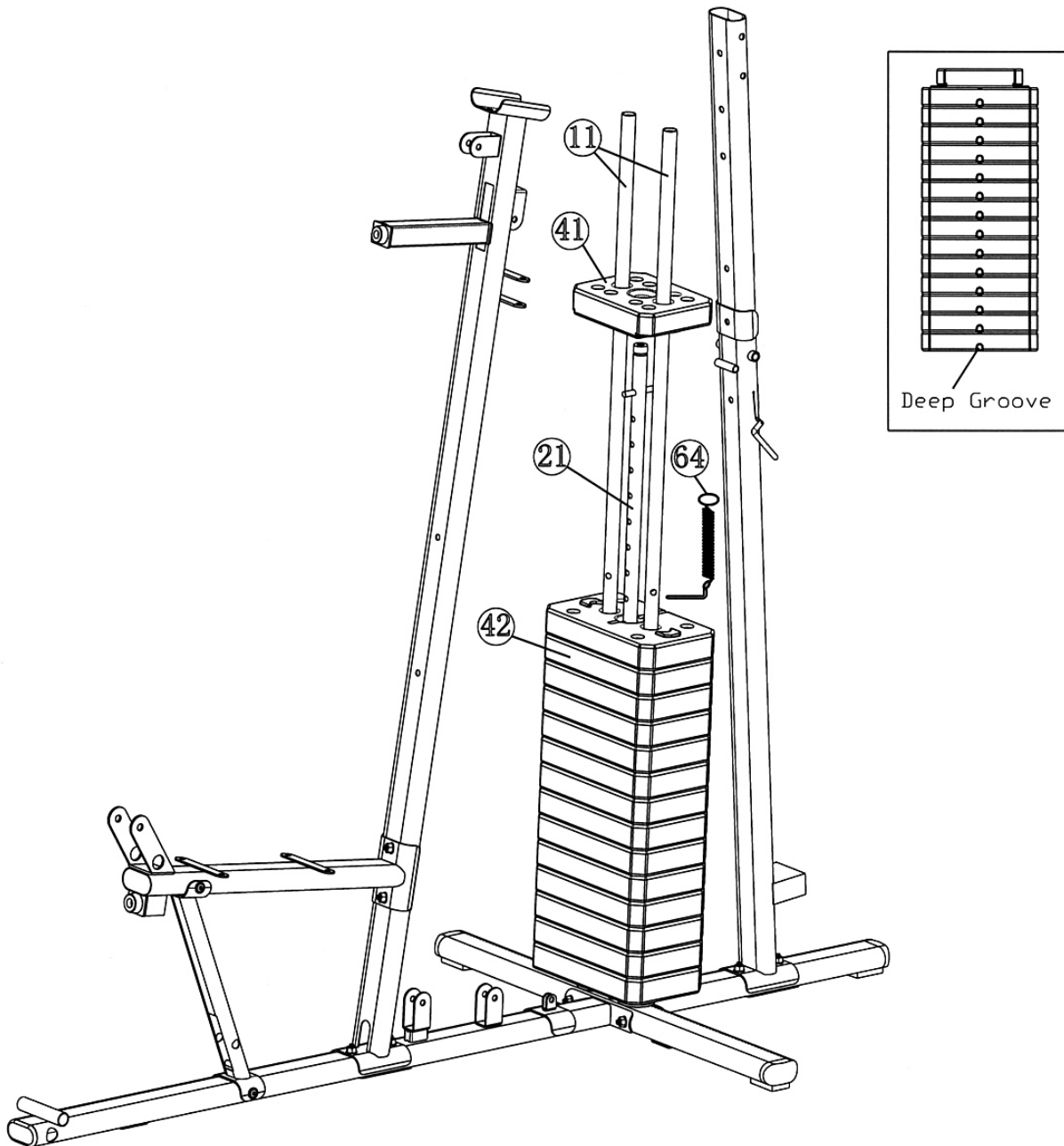

#### **STEP 4 (See Diagram 4)**

- A.) Place the Upper Frame (#1) onto the Vertical Frame (#4).
- B.) Attach the brackets on the Upper Frame to the two Guide Rods. Secure the Guide Rods to the brackets with two M10 x 1" Allen Bolts (#81) and  $\varnothing$   $\frac{3}{4}$ " Washers (#91).
- C.) Secure the Upper Frame to the Power Station Vertical Frame (#26) with two M10 x 2  $\frac{3}{8}$ " Carriage Bolts (#72), one 4  $\frac{3}{4}$ " x 3  $\frac{1}{2}$ " Bracket (#18), two  $\varnothing$   $\frac{3}{4}$ " Washers (#91), and two M10 Aircraft Nuts (#97).
- D.) Secure the Upper Frame to the Vertical Frame with two M10 x 2  $\frac{3}{8}$ " Carriage Bolts (#72), one 4  $\frac{3}{4}$ " x 3  $\frac{1}{2}$ " Bracket (#18), two  $\varnothing$   $\frac{3}{4}$ " Washers (#91), and two M10 Aircraft Nuts (#97).
- E.) **Securely tighten all Nuts and Bolts previously installed in Step-2 and Step-4.**
- F.) Attach the Leg Developer (#7) to the open bracket on Seat Support (#5). Secure it with one M12 x 3  $\frac{1}{8}$ " Allen Bolt (#77), two  $\varnothing$  1" Washers (#92), and one M10 Aircraft Nut (#98).

DIAGRAM 4

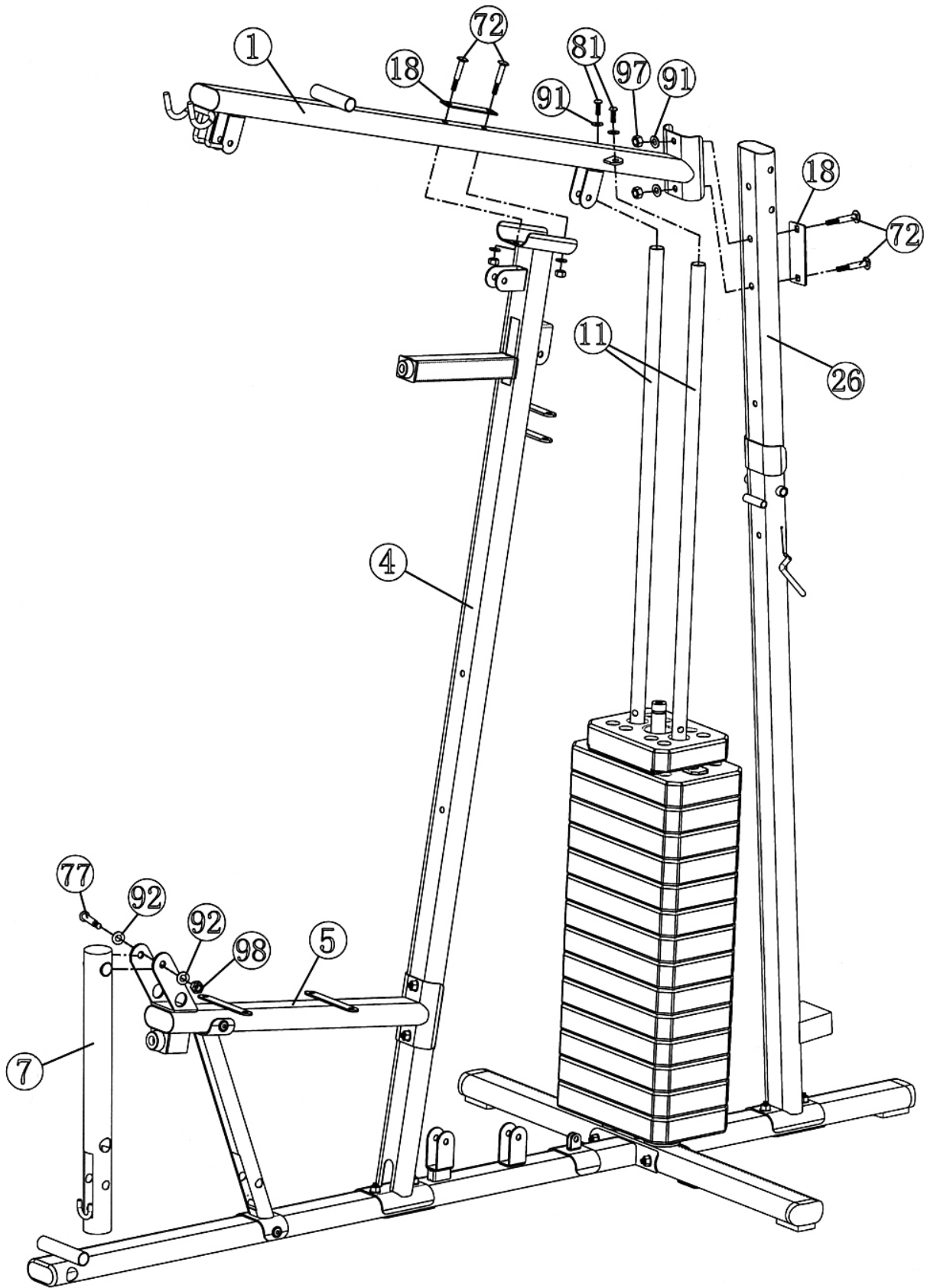

## STEP 5 (See Diagram 5)

- A.) Attach the Front Press Base (#8) to the Upper Frame (#1). Secure it with one 8 ½" Front Press Axle (#19), two Ø 1" Large Washers (#96), and two M10 Aircraft Nuts (#97). **Do not over tighten the Nuts.**
- B.) Insert the axle on the Left Butterfly (#9) through the open hole on Front Press Base from bottom. Secure it with one Ø 1" Large Washer (#96) and one M10 Aircraft Nuts (#97). **Do not over tighten the Nut.** Push one Large Foam Roll (#37) onto the Left Butterfly.
- C.) Repeat Procedure B to install the Right Butterfly (#10).
- D.) Insert the two Butterfly Lock Pins (#60) through the holes on Front Press Base into holes on Butterfly to lock the Butterflies for Front Press exercise.
- E.) Pull out the Butterfly Lock Pins and insert into the other open holes on the Front Press Base for Butterfly exercise.
- F.) Attach Left & Right Chin-up Support (#29 & #30) to Power Station Vertical Frame (#26) from each side.
- G.) Secure them together with one M10 x 2 3/8" Allen Bolt (#82) from front, two Ø ¾" Washers (#91), and one M10 Aircraft Nut (#97). Secure them together with two M10 x 4" Allen Bolts (#83) from side, four Ø ¾" Washers (#91), and two M10 Aircraft Nuts (#97).

# DIAGRAM 5

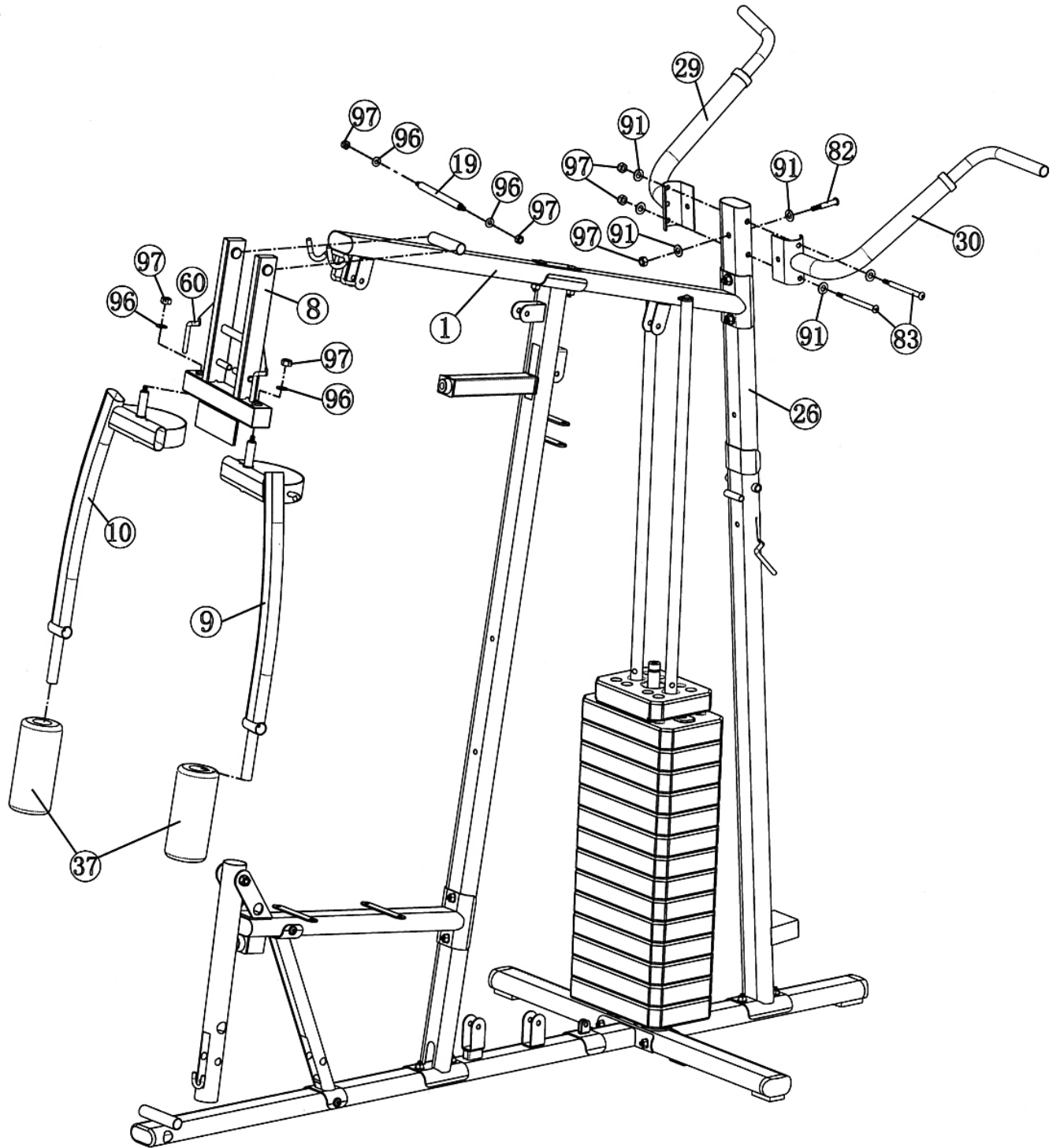

## STEP 6 (See Diagram 6)

- A.) Attach the Left Dip Support (#28) into Right Dip Support (#27) behind the Power Station Vertical Frame (#26).
- B.) Attach the holes on the bracket of Left & Right Dip Support to the hole on the Vertical Frame. Align the holes. Secure the Left & Right Dip Support, and the Vertical Frame together with one M10 x 4 7/8" Hex Bolt (#86), one Ø 1" Washers (#92), one Ø 3/4" Washer (#91), and one M10 Aircraft Nut (#97). **Do not over tighten the Nuts and Bolts. Make sure the Left and Right Dip Support are able to move up freely.**
- C.) Secure the Left & Right Dip Support together with two M10 x 2 1/2" Allen Bolts (#76), two Ø 3/4" x 1 1/8" Curved Washers (#95), and two M10 Aircraft Nuts (#97).
- D.) When doing Chin-up exercise, fold up the Left & Right Dip Support. Insert the 4" Power Station Lock Pin (#62) through the holes on Right Dip Support into the open slot on the back of Power Station Vertical Frame to hold up both Dip Supports in position.



# DIAGRAM 6

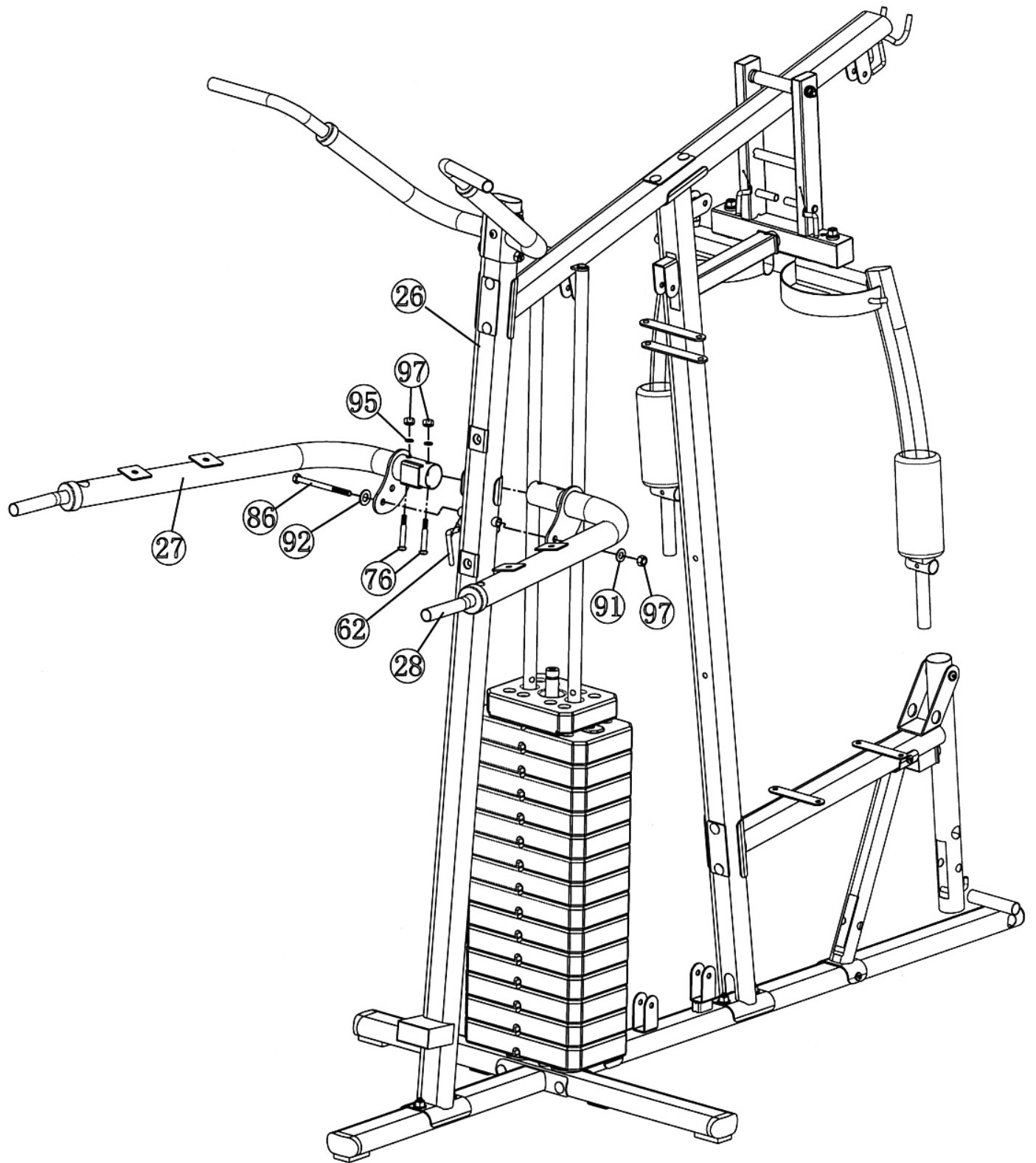

### STEP 7 (See Diagram 7)

- A.) Attach one Swivel Pulley Bracket (#17) to the open bracket on the back of Vertical Frame (#4). Secure it with one M10 x 2 1/2" Allen Bolt (#76), two Ø 3/4" Washers (#91), and one M10 Aircraft Nut (#97). **Do not over tighten the Nut and Bolt. Make sure the Swivel Pulley Bracket can swivel freely.**
- B.) Repeat Procedure A to install the other Swivel Pulley Bracket on the other side.
- C.) Attach a Front Press Handle (#12) to the Left & Right Butterfly (#9 & #10). Secure each Handle with one M8 x 3/4" Allen Bolt (#80) and Ø 5/8 x 1/2" Curved Washer (#93).
- D.) Attach the Backrest Board (#32) to Vertical Frame. Secure it with two M8 x 2 1/8" Allen Bolts (#79) and two Ø 5/8" Washers (#90).
- E.) Attach the Seat Pad (#33) to Seat Support (#5). Secure it with four M8 x 5/8" Allen Bolts (#78) and four Ø 5/8" Washers (#90).

**DIAGRAM 7**

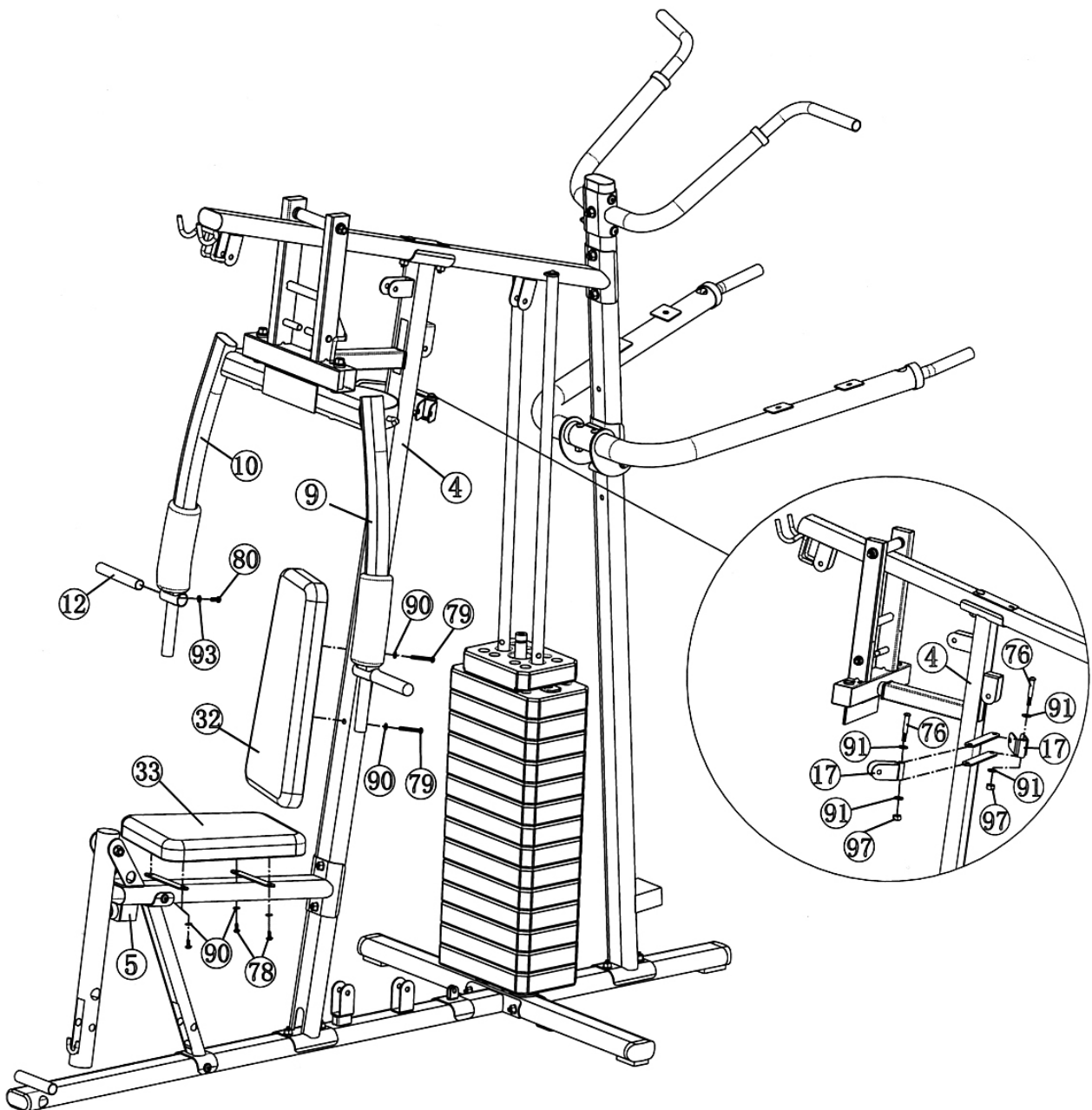

### STEP 8 (See Diagram 8)

- A.) Attach the Power Station Arm Pads (#35) to the Right & Left Dip Support (#27 & #28). Secure each Arm Pad with two M8 x 2 3/4" Allen Bolts (#84) and two Ø 5/8" x 1" Curved Washers (#94).
- B.) Attach two Vertical Handles (#13) to Right & Left Dip Support. Secure each Handle to each Support with one M10 x 1" Allen Bolt (#81) and Ø 3/4" x 1 1/8" Curved Washer (#95).
- C.) Insert 15 3/4" Long Foam Tube halfway through the hole on Seat Support (#5). Insert 15" Short Foam Tube (#23) halfway through the hole on Leg Developer (#7). Push four Foam Rolls (#36) onto the Tubes from each end.
- D.) Attach the Foot Plate (#25) to the pivot on Base Frame (#3). Insert the Foot Plate Axle (#24) through the Foot Plate and the pivot to secure the Foot Plate to the Base Frame.

**DIAGRAM 8**

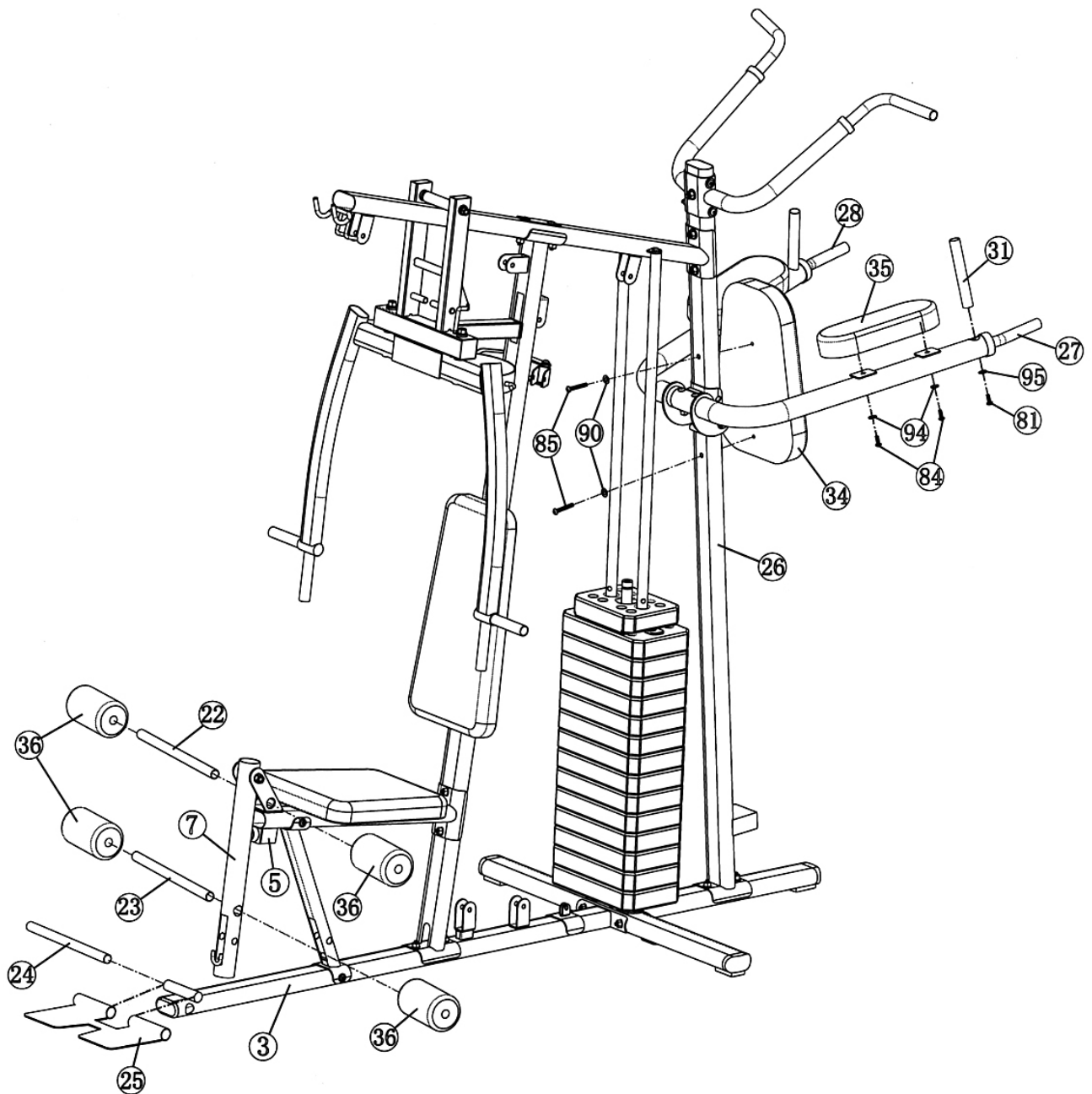

## **STEP 9 (See Diagram 9 & Cable Loop Diagram)**

- A.) Attach the 127 ½" Upper Cable (#56) to the front open bracket under the Upper Frame (#1).
- B.) Attach a Pulley (#40) to the bracket. Secure it with one M10 x 1 ¾" Allen Bolt (#74), two Ø ¾" Washers (#91), and one M10 Aircraft Nut (#97).
- C.) Draw the Cable under the Upper Frame towards the back of the machine to the open bracket on Vertical Frame (#4). Repeat B to install a Pulley.
- D.) Draw the Cable around the Pulley then pull back to the opening on the Front Press Base (#8).
- E.) Attach a Pulley to the opening. Secure it with one M10 x 7 ½" Allen Bolt (#73), two Ø ¾" Washers (#91), and one M10 Aircraft Nut (#97).
- F.) Draw the Cable around the Pulley then through the opening on the Vertical Frame (#4) to the open bracket on the back of Vertical Frame. Repeat Procedure B to install a Pulley.
- G.) Draw the Cable over the Pulley and pull the Cable downwards. Attach a Pulley to the upper hole on the two Double Floating Pulley Brackets (#13). Secure it with one M10 x 2" Allen Bolt (#75), two Ø ¾" Washers (#91), two Cable Retainers (#99), and one M10 Aircraft Nut (#70). Let the Bracket hanging for now.
- H.) Draw the Cable around the Pulley then pull upwards the open bracket under the Upper Frame. Repeat Procedure B to install a Pulley.
- I.) Draw the Cable downwards between the two Guide Rods (#11) to the Selector Rod (#21). Securely thread the bolt on the end of the Cable into the Selector Rod.

DIAGRAM 9

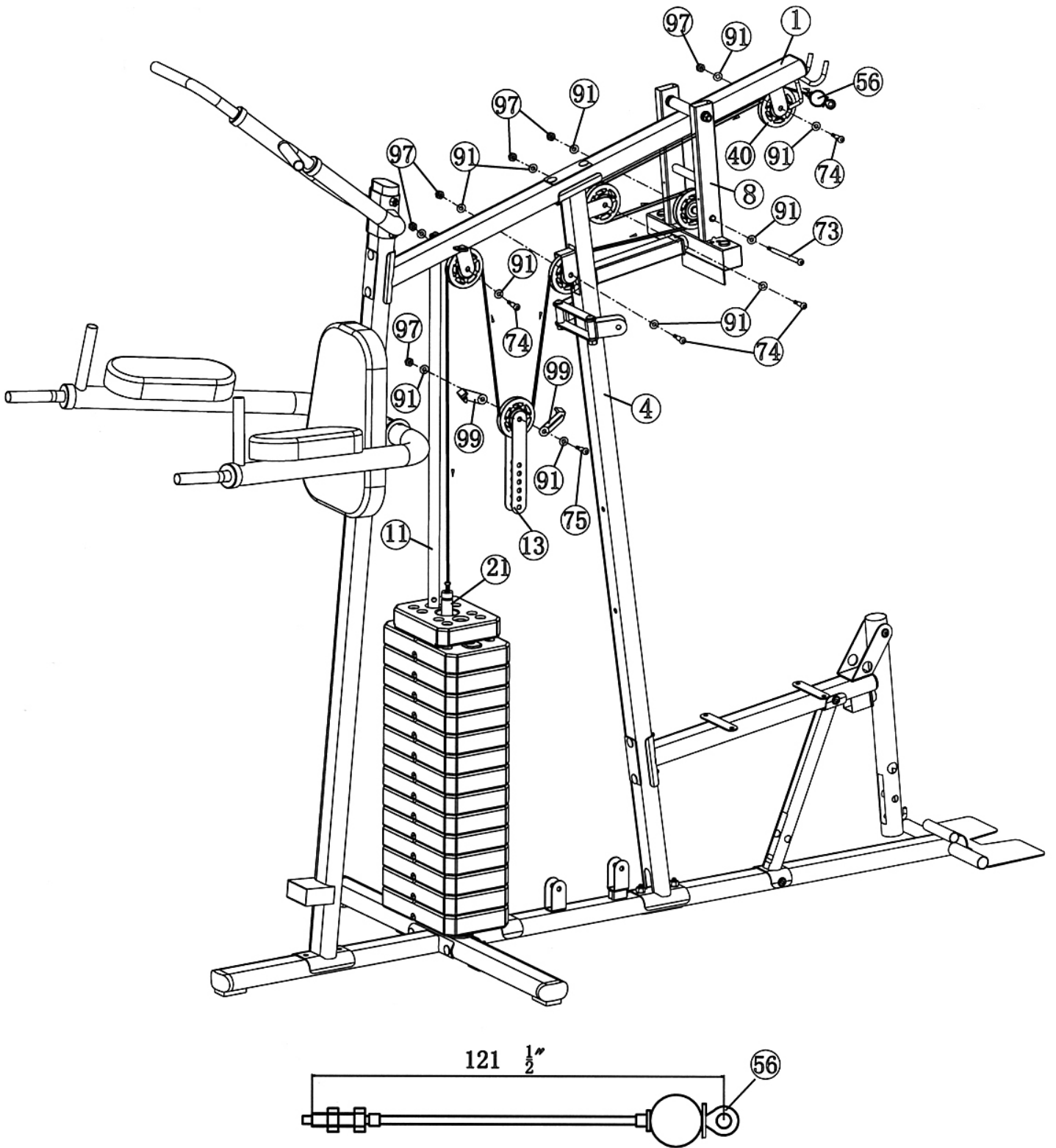

**STEP 10 (See Diagram 10 & Cable Loop Diagram)**

- A.) Hook one end of the 98" Butterfly Cable (#57) to Right Butterfly (#10).
- B.) Draw the Cable towards the right open Swivel Pulley Bracket (#17).
- C.) Attach a Pulley (#40) to the bracket. Secure it with one M10 x 1 3/4" Allen Bolt (#74), two Ø 3/4" Washers (#91), and one M10 Aircraft Nut (#97).
- D.) Draw the Cable over the Pulley then pull downward. Attach the Cable to an Angled Floating Pulley Bracket (#16). Repeat Procedure C to install a Pulley. Let the Bracket hanging for now.
- E.) Draw the Cable around the Pulley and pull upward to the left open Swivel Pulley Bracket (#17). Repeat C to install a Pulley.
- F.) Draw the Cable over the Pulley and hook the end to the Left Butterfly (#9).

**DIAGRAM 10**

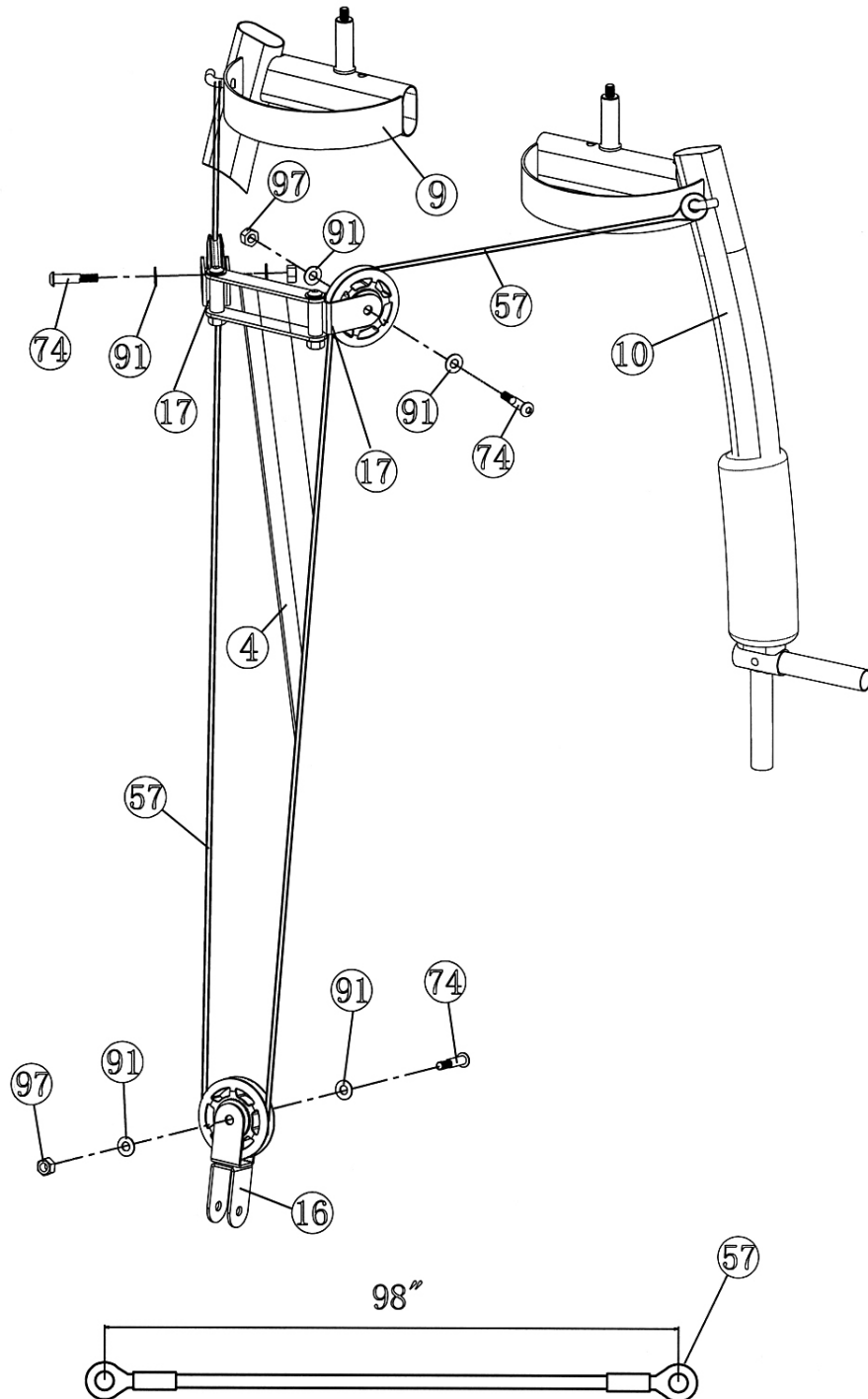

## STEP 11 (See Diagram 11 & Cable Loop Diagram)

- A.) Attach the 159" Lower Cable (#58) to the opening bracket on Leg Developer (#7).
- B.) Attach a Pulley (#40) to the opening. Secure it with one M10 x 2 1/2" Allen Bolt (#76), two  $\varnothing$  1" x 5/8" Pulley Bushings (#52), and one M10 Aircraft Nut (#97).
- C.) Draw the Cable underneath the Pulley to the opening on Vertical Seat Support (#6). Repeat B to install a Pulley.
- D.) Draw the Cable underneath the Pulley through the opening on bottom of Vertical Frame (#4), to the open bracket on Base Frame (#3).
- E.) Attach a Pulley to the bracket. Secure it with one M10 x 1 3/4" Allen Bolt (#74), two  $\varnothing$  3/4" Washers (#91), and one M10 Aircraft Nut (#97).
- F.) Draw the Cable around the Pulley then upward to the Angled Floating Pulley Bracket (#16) installed in Step-10. Repeat E to install a Pulley.
- G.) Draw the Cable around the Pulley then downward to an open bracket on Base Frame. Repeat E to install a Pulley.
- H.) Draw the Cable around the Pulley and pull the Cable upward to the Double Floating Pulley Brackets (#16) previously installed in Step-9.
- I.) Attach a Pulley to selected holes. Secure the Pulley with one M10 x 2" Allen Bolt (#75), two  $\varnothing$  3/4" Washers (#91), two Cable Retainer (#99), and one M10 Aircraft Nut (#97).
- J.) Draw the Cable around the Pulley and downward to the open bracket on Base Frame. Secure the end of Cable to the bracket with one M10 x 1' Allen Bolt (#81), two  $\varnothing$  3/4" Washers (#91), and one M10 Aircraft Nut (#97).
- K.) If the whole Cable system is too loose, adjust the tension of the cable system by moving up or down the lower pulley on the Double Floating Pulley Bracket. Moving up the pulley up will increase the tension in the pulley system; conversely, lowering the pulley will decrease the tension.

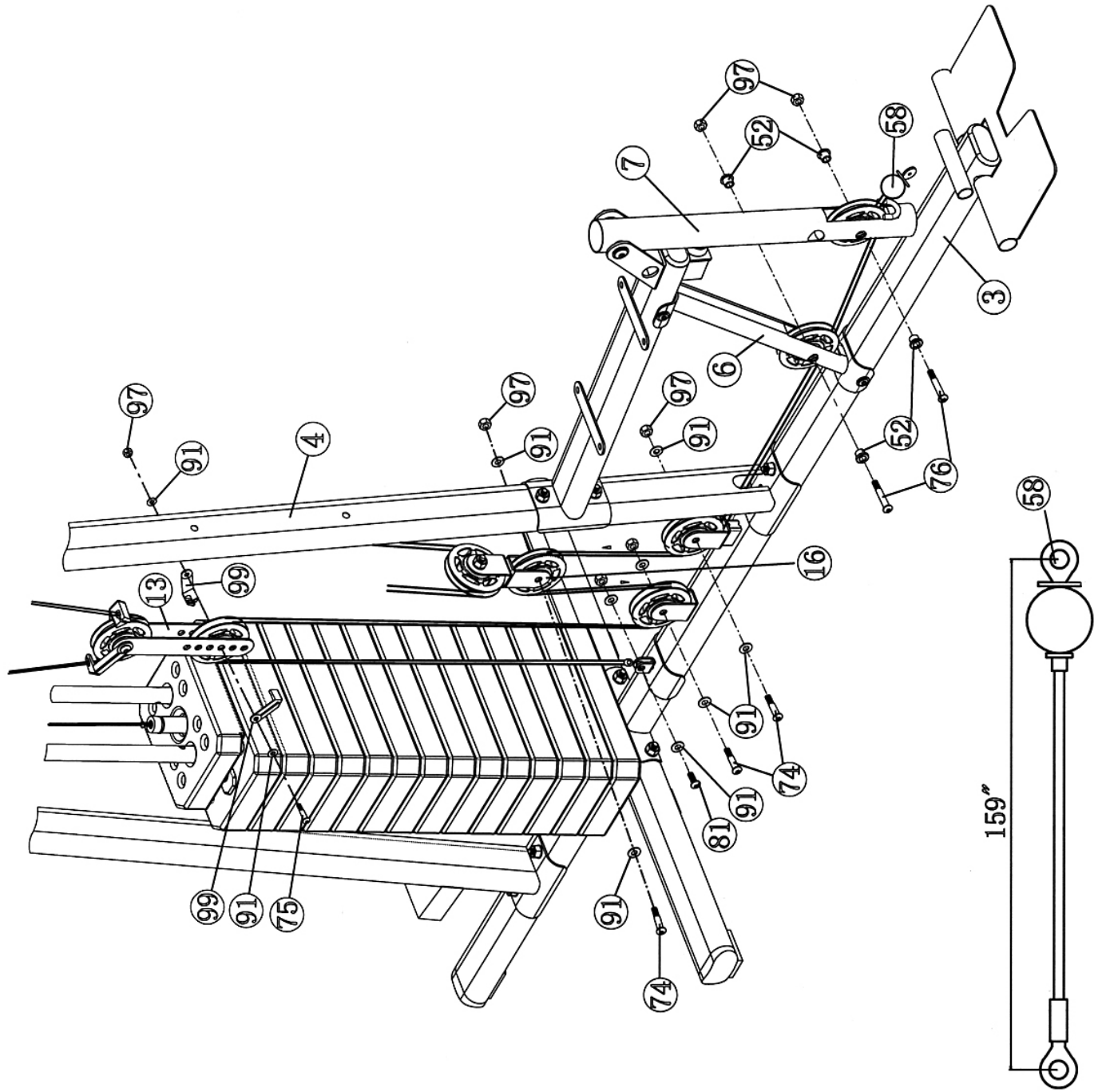



## STEP 12 (See Diagram 12)

- A.) Connect Lat Bar (#14) to the Upper Cable (#56) with two Hooks (#63) and one 15-link Chain (#55) when doing Lat Pull exercises.
- B.) Connect Shiver Bar (#15) to the Lower Cable (#33) use the two Hooks and the 15-link Chain from Lat Bar when doing Arm Curl exercises
- C.) Replace Shiver Bar with the Ankle Strap (#66) or Single Handle (#61) to the Lower Cable for various exercises.
- D.) Insert a 2" Weight Plate Lock Pin (#54) through the hole on Guide Rod and lock with a Combination Lock (#53) to prevent any un-authorized usage of the machine.
- E.) Unlock the Lock and attach it to Selector Rod before using the machine.

### DIAGRAM 12

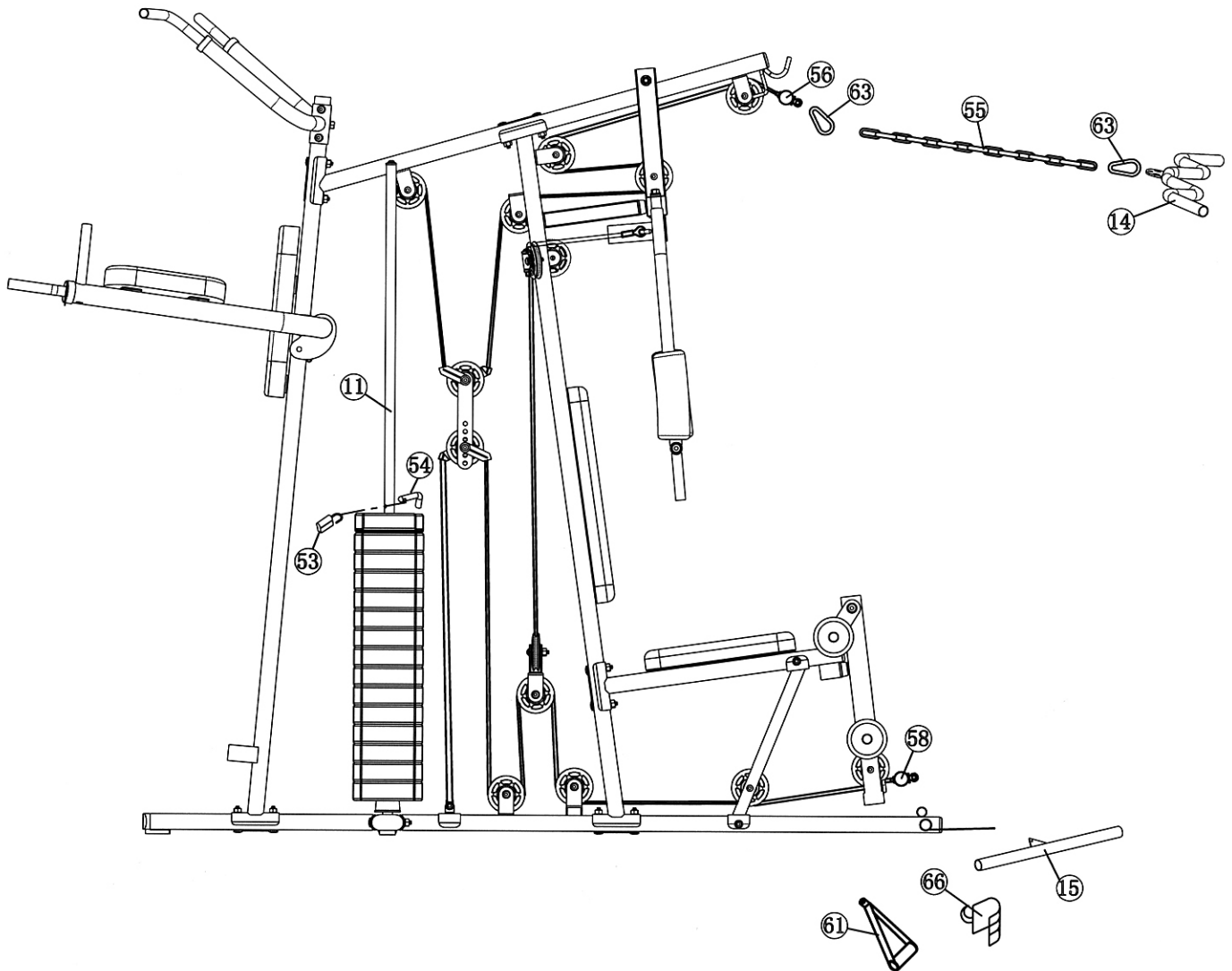

## Set up the Lock Combination

- A.) The combination is pre-set to 0-0-0 by the factory.
- B.) Turn the dials to 0-0-0 and aligned to the Combination Set Up Line.
- C.) Pull out the shackle and turn 180°.
- D.) Press down on the shackle.
- E.) Turn the dials (aligned to the Combination Set Up Line) to your desired combination.
- F.) Pull out the shackle and twist back to normal position and the combination are set.
- G.) Repeat Procedure C to F to re-set the combination.

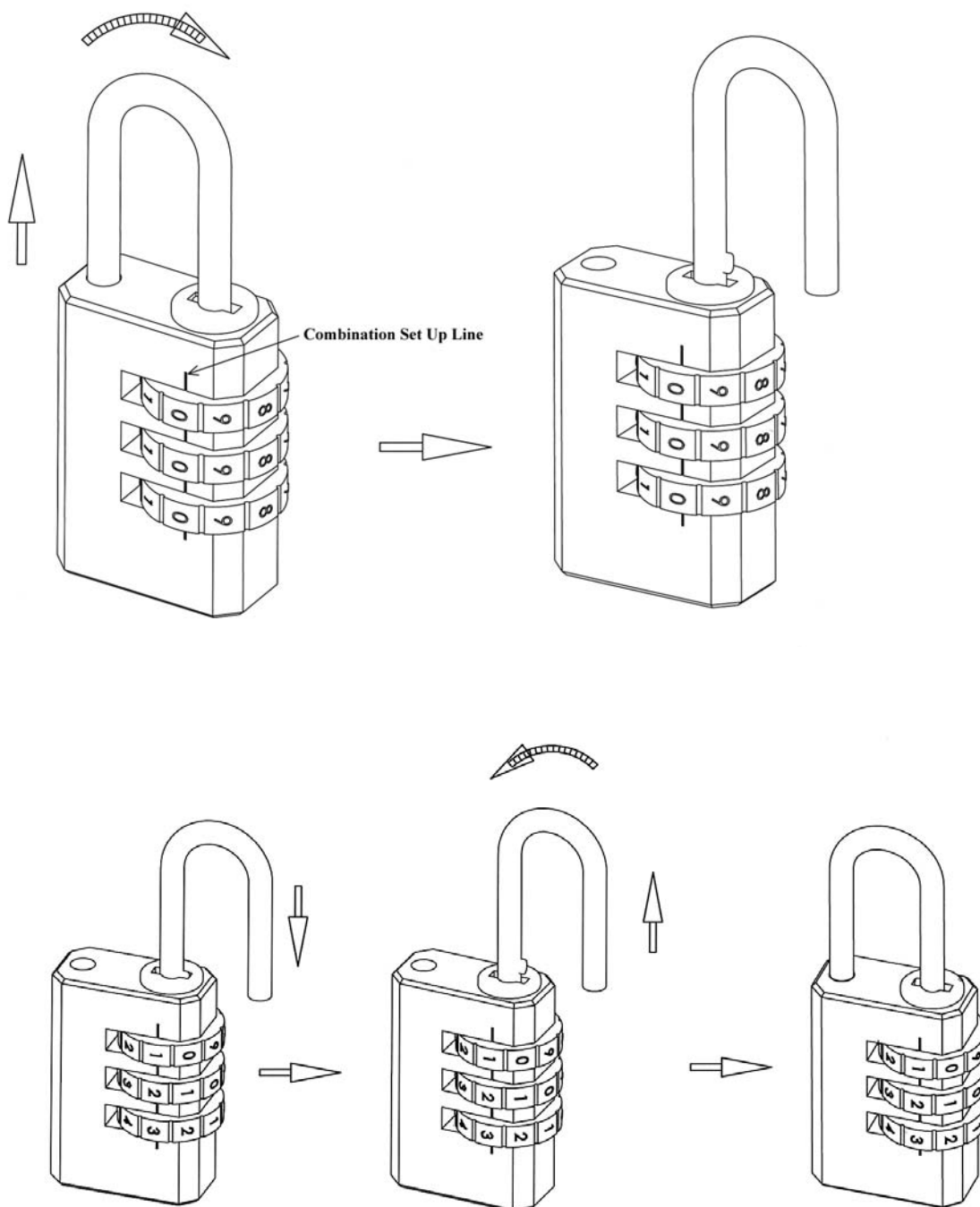

## PARTS LIST

KEY NO.	DESCRIPTION	Q'ty			
1	Upper Frame	1	51	Ø 1" x Ø ½" Bushing	2
2	Middle Stabilizer	1	52	Ø 1" x 5/8" Pulley Bushing	4
3	Base Frame	1	53	Combination Lock	1
4	Vertical Frame	1	54	2" Weight Plate Lock Pin	1
5	Seat Support	1	55	15-link Chain	1
6	Vertical Seat Support	1	56	127 ½" Upper Cable	1
7	Leg Developer	1	57	98" Butterfly Cable	1
8	Front Press Base	1	58	159" Lower Cable	1
9	Left Butterfly	1	59	Stabilizer End Cap	3
10	Right Butterfly	1	60	3 3/8" Butterfly Lock Pin	2
11	Guide Rod	2	61	Single Handle	1
12	Front Press Handle	2	62	4" Power Station Lock Pin	1
13	Double Floating Pulley Bracket	2	63	Hook	2
14	Lat Bar	1	64	Weight Selector Pin	1
15	Shiver Bar	1	65	1 ½" Square End Cap	1
16	Angled Floating Pulley Bracket	1	66	Ankle Strap	1
17	Swivel Pulley Bracket	2	67	Ø 2" x Ø 1" Sleeve	2
18	4 ¾" x 3 ½" Bracket	5	68	Ø 1 ½" x Ø 1" Sleeve	2
19	8 ½" Front Press Axle	1	69	4 ¾" Grip	12
20	Rear Stabilizer	1	70	6" Grip	2
21	Selector Rod	1	71	M10 x 4" Carriage Bolt	2
22	15" ¾" Long Foam Tube	1	72	M10 x 2 3/8" Carriage Bolt	10
23	15" Short Foam Tube	1	73	M10 x 7 ½" Allen Bolt	1
24	Foot Plate Axle	1	74	M10 x 1 ¾" Allen Bolt	10
25	Foot Plate	1	75	M10 x 2" Allen Bolt	2
26	Power Station Vertical Frame	1	76	M10 x 2 ½" Allen Bolt	6
27	Right Dip Support	1	77	M12 x 3 1/8" Allen Bolt	1
28	Left Dip Support	1	78	M8 x 5/8" Allen Bolt	4
29	Left Chin-up Support	1	79	M8 x 2 1/8" Allen Bolt	2
30	Right Chin-up Support	1	80	M8 x ¾" Allen Bolt	2
31	Vertical Handle	2	81	M10 x 1" Allen Bolt	11
32	Backrest Board	1	82	M10 x 2 3/8" Allen Bolt	1
33	Seat Pad	1	83	M10 x 4" Allen Bolt	2
34	Power Station Backrest Board	1	84	M8 x 2 ¾" Allen Bolt	4
35	Power Station Arm Pad	2	85	M8 x 2 3/8" Allen Bolt	2
36	Foam Roll	4	86	M10 x 4 7/8" Hex Bolt	1
37	Large Foam Roll	2	87	Philips Screw	2
38	Rubber Bumper	2	88	ST5 x 3/8" Self-tapping Screw	2
39	Ø 2 ¼" x 1" Guide Rod Rubber Bumper	2	89	ST5 x 5/8" Self-tapping Screw	1
40	Pulley	15	90	Ø 5/8" Washer	8
41	Selector Stem	1	91	Ø ¾" Washer	59
42	Weight Plate	14	92	Ø 1" Washer	3
43	1" x 2" End Cap	2	93	Ø 5/8" x ½" Curved Washer	2
44	2" Square End Cap	2	94	Ø 5/8" x 1" Curved Washer	4
45	1 5/8" x 3 1/8" End Cap	4	95	Ø ¾" x 1 1/8" Curved Washer	4
46	1 1/8" x 2 3/8" End Cap	4	96	Ø 1" Large Washer	4
47	Ø 1" Cone-shaped End Cap	1	97	M10 Aircraft Nut	40
48	Ø 1" End Cap	8	98	M12 Aircraft Nut	1
49	Ø 2" End Cap	2	99	Cable Retainer	4
50	Ø 1" x Ø 5/8" Bushing	6			

## MWM1840 WEIGHT RESISTANCE CHART

Weight Plate	Leg Developer	Front Press	Butterfly	Lat Pull	Low Pulley
1	30	31	15	30	30
2	40	44	20	40	40
3	50	57	25	50	50
4	60	70	30	60	60
5	70	83	35	70	70
6	80	96	40	80	80
7	90	109	45	90	90
8	100	122	50	100	100
9	110	135	55	110	110
10	120	148	60	120	120
11	130	161	65	130	130
12	140	174	75	140	140
13	150	187	80	150	150
14	160	200	85	160	160

**Note: Each plate weights 10 lbs.**

**Numbers are approximate. Actual weights may vary.**

**Values for Butterfly are for each arm.**

# **IMPEX<sup>®</sup> INC.**

## **LIMITED WARRANTY**

IMPEX Inc. ("IMPEX<sup>®</sup>") warrants this product to be free from defects in workmanship and material, under normal use and service conditions, for a period of two years on the Frame from the date of purchase. This warranty extends only to the original purchaser. IMPEX's obligation under this Warranty is limited to replacing or repairing, at IMPEX's option.

All returns must be pre-authorized by IMPEX. Pre-authorization may be obtained by calling IMPEX Customer Service Department at 1-800-999-8899. All freights on products returned to IMPEX must be prepaid by the customer. This warranty does not extend to any product or damage to a product caused by or attributable to freight damage, abuse, misuse, improper or abnormal usage or repairs not provided by an IMPEX authorized service center or for products used for commercial or rental purposes. No other warranty beyond that specifically set forth above is authorized by IMPEX.

IMPEX is not responsible or liable for indirect, special or consequential damages arising out of or in connection with the use or performance of the product or other damages with respect to any economic loss, loss of property, loss of revenues or profits, loss of enjoyments or use, costs of removal, installation or other consequential damages or whatsoever natures. Some states do not allow the exclusion or limitation of incidental or consequential damages. Accordingly, the above limitation may not apply to you.

The warranty extended hereunder is in lieu of any and all other warranties and any implied warranties of merchantability or fitness for a particular purpose is limited in its scope and duration to the terms set forth herein. Some states do not allow limitations on how long an implied warranty lasts. Accordingly, the above limitation may not apply to you.

This warranty gives you specific legal right. You may also have other rights which vary from state to state.  
**Register on-line at [www.impex-fitness.com](http://www.impex-fitness.com)**

**IMPEX<sup>®</sup> INC.  
14777 Don Julian  
City of Industry, CA 91746**

### **ORDERING REPLACEMENT PARTS**

Replacement parts can be ordered by calling our Customer Service Department toll-free at **1-800-999-8899** during our regular business hours: Monday through Friday, 9 am until 5 pm Pacific standard time.

**[info@impex-fitness.com](mailto:info@impex-fitness.com)**

When ordering replacement parts, always give the following information.

1. Model
2. Description of Parts
3. Part Number
4. Date of Purchase