

NOTE:
Please read all
instructions carefully
before using this product

Table of Contents

Safety Notice

Hardware Pack

Assembly Instruction

Parts List

Warranty

Ordering Parts

**Model
NS-753**

Retain This
Manual for
Reference

180608

**OWNER'S
MANUAL**

IMPEX

MARCY® Foldable Bike NS-753

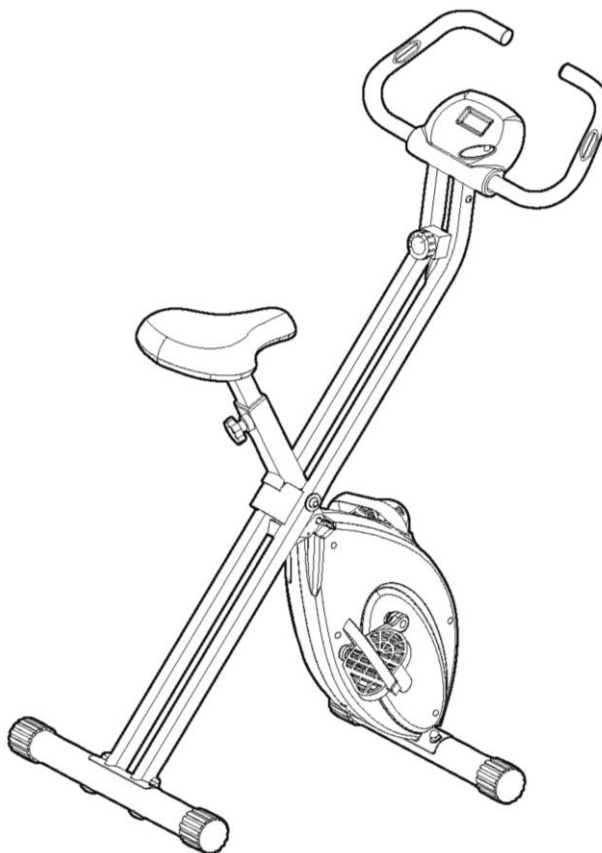

IMPEX® INC.

2801 S. Towne Ave, Pomona, CA 91766
Tel: (800) 999-8899

www.marcypro.com

support@impex-fitness.com

TABLE OF CONTENTS

| | |
|--------------------------|----|
| BEFORE YOU BEGIN | 1 |
| IMPORTANT SAFETY NOTICES | 2 |
| WARNING LABEL PLACEMENT | 3 |
| HARDWARE PACK | 4 |
| ASSEMBLY INSTRUCTION | 5 |
| EXPLODED DIAGRAM | 9 |
| PARTS LIST | 10 |
| COMPUTER INSTRUCTIONS | 13 |
| EXERCISE GUIDELINES | 14 |
| WARRANTY | 16 |
| ORDERING PARTS | 16 |

BEFORE YOU BEGIN

Thank you for selecting the MARCY® NS-753 by IMPEX® INC. For your safety and benefit, read this manual carefully before using the machine. As a manufacturer, we are committed to provide you complete customer satisfaction. If you have any questions, or find there are missing or damaged parts, we guarantee you complete satisfaction through direct assistance from our factory. To avoid unnecessary delays, *please call our TOLL-FREE customer service number.* Our Customer Service Agents will provide immediate assistance to you.

Toll-Free Customer Service Number

1-800-999-8899

Mon. - Fri. 9 a.m. - 5 p.m. PST

www.marcypro.com

support@impex-fitness.com

IMPORTANT SAFETY NOTICE

PRECAUTIONS

This exercise machine is built for optimum safety. However, certain precautions apply whenever you operate a piece of exercise equipment. Be sure to read the entire manual before you assemble or operate your machine. In particular, note the following safety precautions:

1. **Keep children and pets away from the machine at all times. DO NOT leave children unattended in the same room with the machine.**
2. Only one person at a time should use the machine.
3. If the user experiences dizziness, nausea, chest pain, or any other abnormal symptoms, STOP the workout at once. CONSULT A PHYSICIAN IMMEDIATELY.
4. Position the machine on a clear, leveled surface. DO NOT use the machine near water or outdoors.
5. Keep hands away from all moving parts.
6. Always wear appropriate workout clothing when exercising. DO NOT wear robes or other clothing that could become caught in the machine. Running or aerobic shoes are also required when using the machine.
7. Use the machine only for its intended use as described in this manual. DO NOT use attachments not recommended by the manufacturer.
8. Do not place any sharp object around the machine.
9. Disabled person should not use the machine without a qualified person or physician in attendance.
10. Before using the machine to exercise, always do stretching exercises to properly warm up.
11. Never operate the machine if the machine is not functioning properly.
12. **The Maximum Weight Capacity is 250 lbs.**
13. Read all warnings posted on the exercise bike.
14. Inspect the exercise bike for worn or loose component prior to use.
Tighten/replace any loose or wore components prior to use.
15. Care should be taken in mounting or dismounting the exercise bike.
16. This exercise bike is for consumer and home use only.

WARNING: BEFORE BEGINNING ANY EXERCISE PROGRAM, CONSULT YOUR PHYSICIAN. THIS IS ESPECIALLY IMPORTANT FOR INDIVIDUALS OVER THE AGE OF 35 OR PERSONS WITH PRE-EXISTING HEALTH PROBLEMS. READ ALL INSTRUCTIONS BEFORE USING ANY FITNESS EQUIPMENT. IMPEX INC. ASSUMES NO RESPONSIBILITY FOR PERSONAL INJURY OR PROPERTY DAMAGE SUSTAINED BY OR THROUGH THE USE OF THIS PRODUCT.

SAVE THESE INSTRUCTIONS.



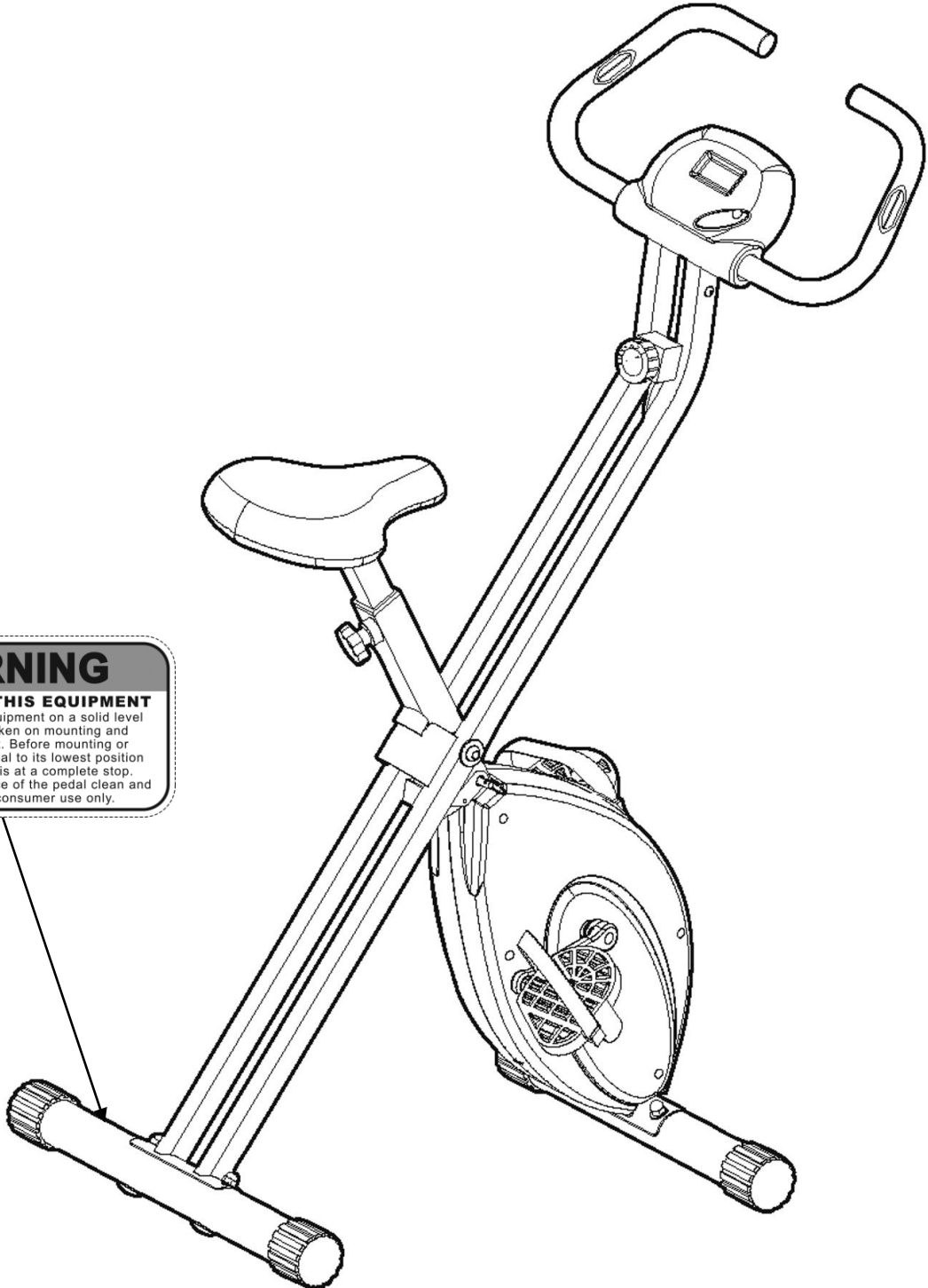



WARNING LABEL REPLACEMENT

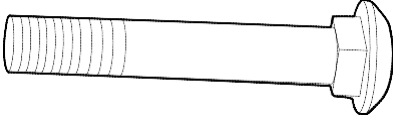
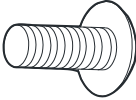

! WARNING
DO NOT MISUSE THIS EQUIPMENT
Set up and operate the equipment on a solid level surface. Care should be taken on mounting and dismounting the equipment. Before mounting or dismounting, move the pedal to its lowest position and ensure the equipment is at a complete stop. Always keep the top surface of the pedal clean and dry. This equipment is for consumer use only.

The Warning Label shown here has been placed on the rear Stabilizer. If the label is missing or illegible, please call customer service at 1-800-999-8899 for replacement. Apply the label in location shown.

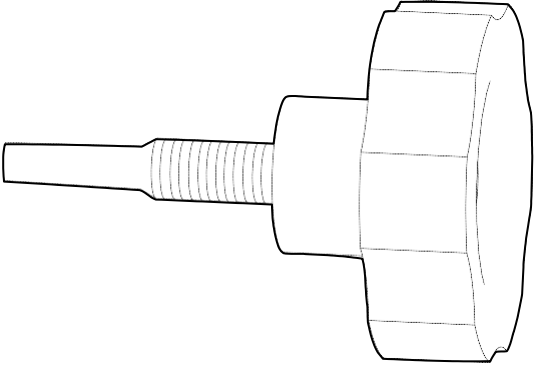
HARDWARE PACK

| | |
|--|--|
| <p>12.</p>  <p>Carriage Bolt x 4pcs</p> | <p>14.</p>  <p>Pan Head Allen Bolt x 4pcs</p> |
| <p>29.</p>  <p>Acorn Nut x 4pcs</p> | <p>33.</p>  <p>Flat Washer x 2pcs</p> |
| <p>38.</p>  <p>Curve Washer x 4pcs</p> | <p>56.</p>  <p>Locking Knob x 1pc</p> |
| <p>38A.</p>  <p>Curve Washer x 2pcs</p> | |
| <p>39.</p>  <p>Locking Washer x 4pcs</p> | |

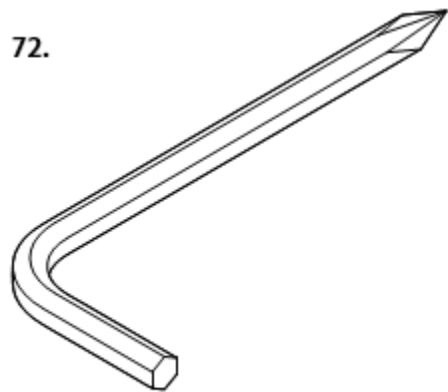

Allen Key x 1pc

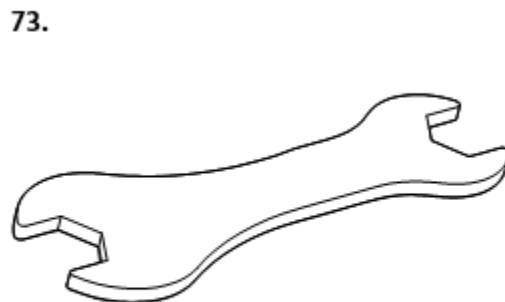

Wrench x 1pc

Above hardware are all you need to assemble this machine. Before you start to assemble, please check the hardware pack to make sure they are included.

ASSEMBLY INSTRUCTION

Step 1

- Pull the Safety-pin (46) as shown in the picture; insert the Safety-pin (46) after completely opening the F-Bike.

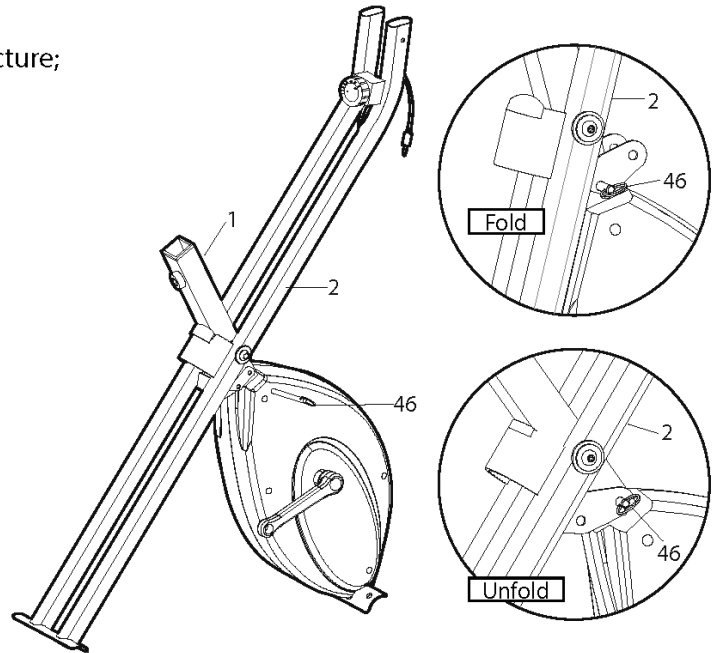

Step 2

- Attach the Front Stabilizer (5A) to the Mainframe (1 and 2), tighten two sets of M8 x 60mm Carriage Bolt (12) and Curve Washer (38) and M8 Domed Nut (29). Then, attach the Rear Stabilizer (5B) to the Mainframe (1 and 2), tighten two sets of M8 x 60mm Carriage Bolt (12) and Curve Washer (38) and M8 Domed Nut (29).

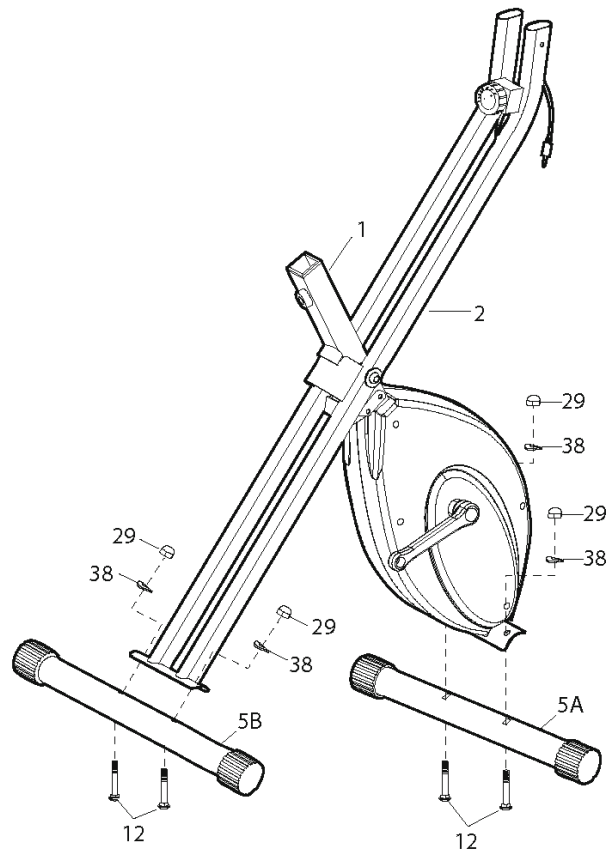

Step 3

- The Left and Right Pedal (61 and 62) are marked "L" and "R". Connect them to their appropriate Crank Arm. The right pedal is on the right hand side of the cycle as you sit on it.
- Note that the right pedal should be threaded on clockwise and the left pedal on counterclockwise.

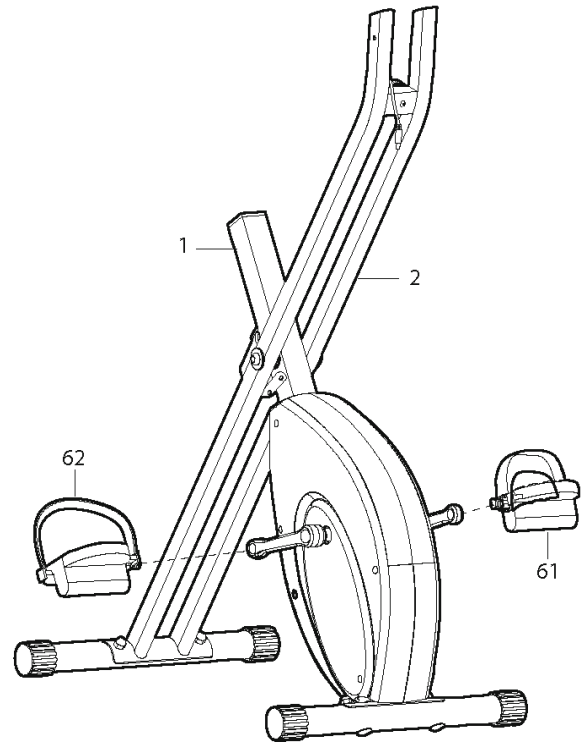

Step 4

- Lock the Seat (69) to the Seat Post (3) with Nut (75) and Washer (74), then insert into the Front Support Tube (1). Line up the holes and secure the seat in position with the Adjustment Knob (56).
- The correct height for the seat can be adjusted.

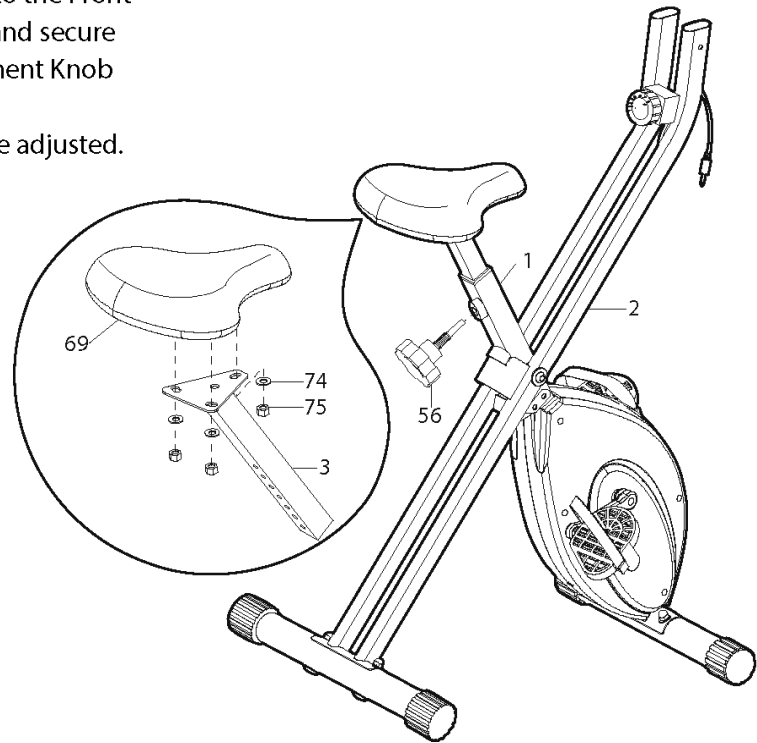

Step 5

- Fix the Handlebar (4) to the Rear support tube (2) and tighten with four sets of M6 x 12mm Allen Bolt (14) and Spring Washer (39), two sets Cover Washer (38A) and Flat Washer (33).

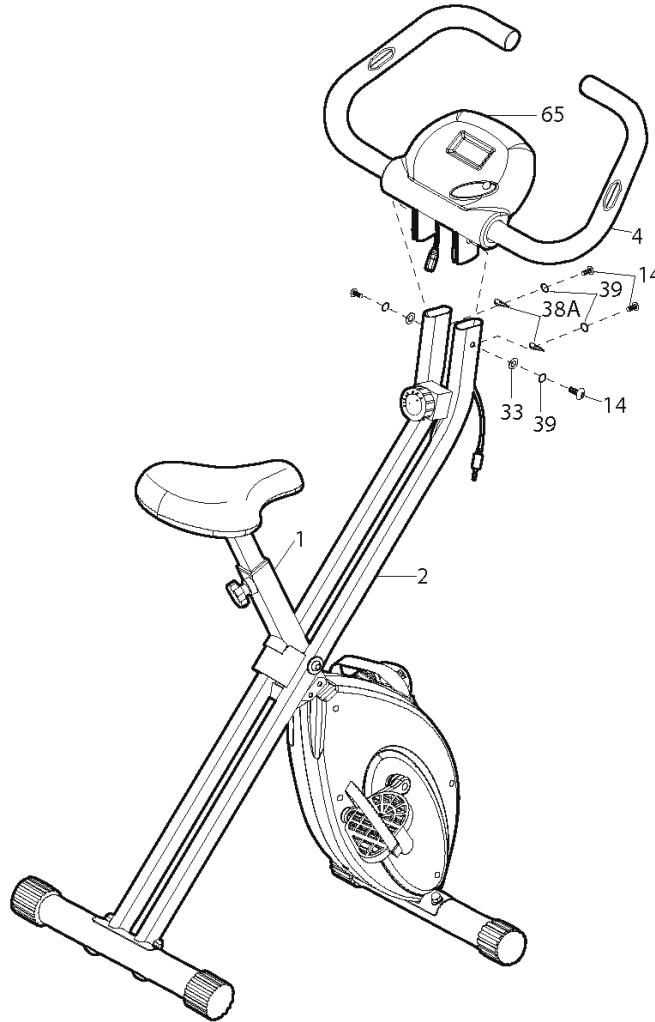

Step 6

- Ensure the Computer Wire is protruding from the gap at the rear of the Main frame (1 and 2), then connect the Upper Computer Wire. Plug the Pulse Wire into the hole at the rear of the Computer (65).

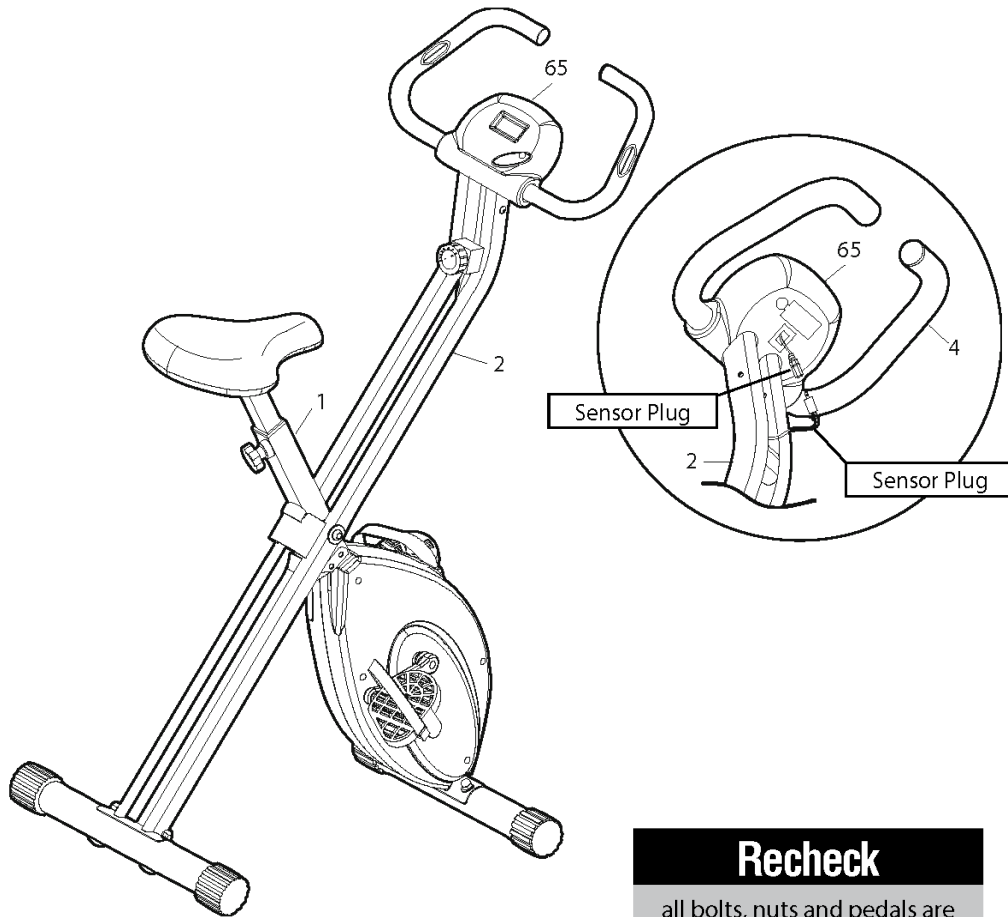

Recheck

all bolts, nuts and pedals are
tightened securely
before use the machine

EXPLODED DIAGRAM

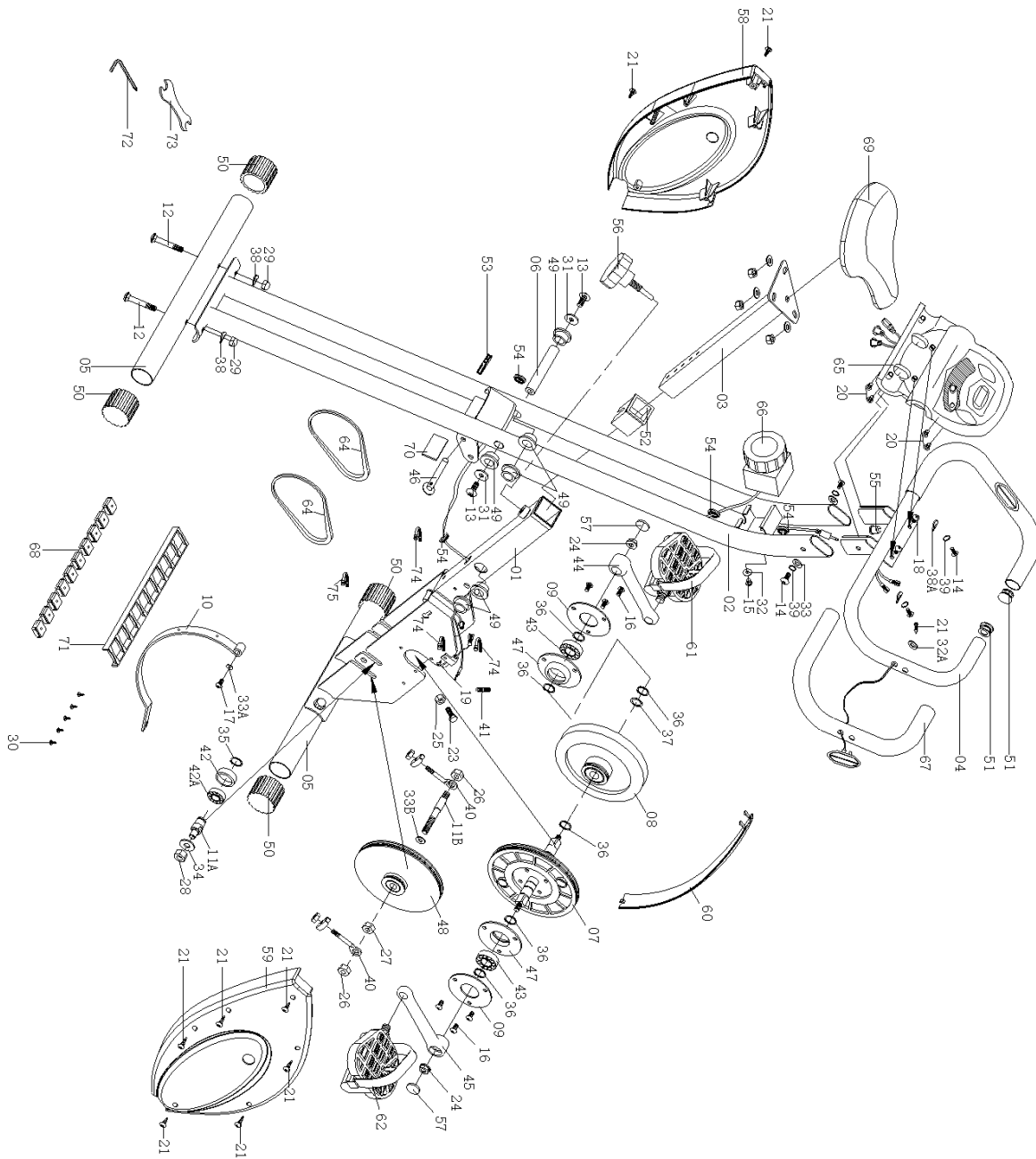

PARTS LIST

| Part # | Description | Size | Qty |
|--------|-------------|------|-----|
|--------|-------------|------|-----|

| | | | |
|-----|-------------------------------|-------------|----|
| 1 | Front Main Frame | | 1 |
| 2 | Rear Main Frame | | 1 |
| 3 | Seat Post | | 1 |
| 4 | Handlebar | | 1 |
| 5. | Stabilizer | | 2 |
| 6 | Axel | | 1 |
| 7 | Crank Wheel | | 1 |
| 8 | Fly Wheel | | 1 |
| 9 | Bearing Bracket Cover | | 2 |
| 10 | Magnet Set | | 1 |
| 11A | Belt Tensioner Axel | | 1 |
| 11B | Belt Pulley Axel | | 1 |
| 12 | Carriage Bolt | | 4 |
| 13 | Pan Head Allen Bolt | M8 x 7/8" | 2 |
| 14 | Pan Head Allen Bolt | M6 x 1/2" | 4 |
| 15 | Truss Head Philips Screw | M5 x 3/4" | 1 |
| 16 | Philips Screw | M6 x 3/8" | 6 |
| 17 | Truss Head Philips Screw | M5 x 3/8" | 1 |
| 18 | Pan Head Philips Screw | M5 x 1/3" | 2 |
| 19 | Pan Head Philips Screw | M4 x 3/8" | 1 |
| 20 | Pan Head Self-tapping Screw | 1/3" | 4 |
| 21 | Truss Head Self-tapping Screw | 3/4" | 10 |
| 23 | Hex Bolt | M6 x 1 1/4" | 1 |
| 24 | Flange Nut | | 2 |
| 25 | Hex Nut | M6 x 1/4" | 1 |
| 26 | Hex Nut | M10 x 1/3" | 2 |
| 27 | Step Nut | | 1 |
| 28 | Aircraft Nut | M10 | 1 |
| 29 | Acorn Nut | | 4 |
| 30 | Self-tapping screw | | 5 |
| 31 | Washer | 1" | 2 |
| 32 | Washer | 3/4" | 1 |
| 32A | Washer | 1/3" | 2 |
| 33 | Washer | 1/2" | 2 |
| 33A | Plastic Washer | 1/4" | 1 |
| 33B | Plastic Washer | 1/2" | 1 |
| 34 | Washer | 1" | 1 |

| | | | |
|-----|-----------------------------|------|----|
| 35 | Tensioner O-Ring | | 1 |
| 36 | O-Ring | | 6 |
| 37 | Spring Washer | | 1 |
| 38 | Curved Washer | 7/8" | 6 |
| 38A | Curved Washer | 1/2" | 2 |
| 39 | Locking washer | | 4 |
| 40 | Belt Pulley Adjustment Bolt | | 2 |
| 41 | Spring | | 1 |
| 42 | Bearing Sleeve | | 1 |
| 42A | Bearing | | 1 |
| 43 | Bearing | | 2 |
| 44 | Left Crank | | 1 |
| 45 | Right Crank | | 1 |
| 46 | Locking Pin | | 1 |
| 47 | Bearing Bracket | | 2 |
| 48 | Belt Pulley | | 1 |
| 49 | Bushing | | 6 |
| 50 | Stabilizer End Cap | | 4 |
| 51 | Handlebar End Cap | | 2 |
| 52 | Seat Post Sleeve | | 1 |
| 53 | Bumper | | 1 |
| 54 | Grommet | | 4 |
| 55 | Cable Sleeve | | 1 |
| 56 | Locking Knob | | 1 |
| 57 | Crank End Cap | | 2 |
| 58 | Left Cover | | 1 |
| 59 | Right Cover | | 1 |
| 60 | Top Cover | | 1 |
| 61 | Left Pedal | | 1 |
| 62 | Right Pedal | | 1 |
| 64 | Belt | | 2 |
| 65 | Computer | | 1 |
| 66 | Tension Knob | | 1 |
| 67 | Foam | | 2 |
| 68 | Magnet | | 10 |
| 69 | Seat | | 1 |
| 70 | EVA Foam | | 1 |

| | | | |
|----|----------------|--|---|
| 71 | Magnet Bracket | | 1 |
| 72 | Allen Key | | 1 |
| 73 | Wrench | | 1 |
| 74 | Cable Clip | | 3 |
| 75 | Cable Clip | | 1 |

COMPUTER



AUTO START / STOP

When exercise starts, the monitor will automatically turn on and display the progress. When exercise stops, the monitor will automatically turn off after 5 minutes to save energy.

Press "MODE" key, will automatically scan Time, Speed, Distance, Calories, and ODO for every 4 seconds.

The below data will display while pedaling.

| | |
|-----------------------|--|
| Time | Display the elapsed time. Max value is up to 99:59 |
| Speed | Display the current speed in miles per hour. |
| Distance | Display the distance traveled in Miles. Max value is 99.99 miles. |
| Calories | Display the calorie consumption in cal. |
| (ODO) Odometer | Display the accumulation of distance from previous and current exercises. Max value is 9999 miles. |

REPLACE BATTERY:

1. Always purchase the correct size and grade of battery most suitable for the intended use.
2. Replace all batteries of a set at the same time.
3. Clean the battery contacts and also those of the device prior to battery installation.
4. Ensure the batteries are installed correctly with regard to polarity (+ and -).
5. Remove batteries from equipment when not in use for extended periods of time.
6. Remove used batteries promptly.
7. The Computer requires two 1.5V (AAA) batteries. Batteries are not included in packaging.
8. If the display is not clear or only partial segments appeared, remove the batteries and wait for 15 seconds before re-install them.
9. The battery life is approx. 3 months under normal usage.
10. **When the batteries are removed, all the functional values will reset to zero.**

Note:

Please note all values on this computer are approximate and they are for comparison purpose only. Do not use these values for any medical or rehabilitation purpose.

EXERCISE INSTRUCTIONS

Using your **FOLDABLE BIKE** will provide you with several benefits, it will improve your

physical fitness, tone muscle and in conjunction with calorie controlled diet help you lose weight.

1. The Warm Up Phase

This stage helps get the blood flowing around the body and the muscles working properly. It will also reduce the risk of cramp and muscle injury. It is advisable to do a few stretching exercises as shown below. Each stretch should be held for approximately 30 seconds, do not force or jerk your muscles into a stretch - if it hurts, STOP.

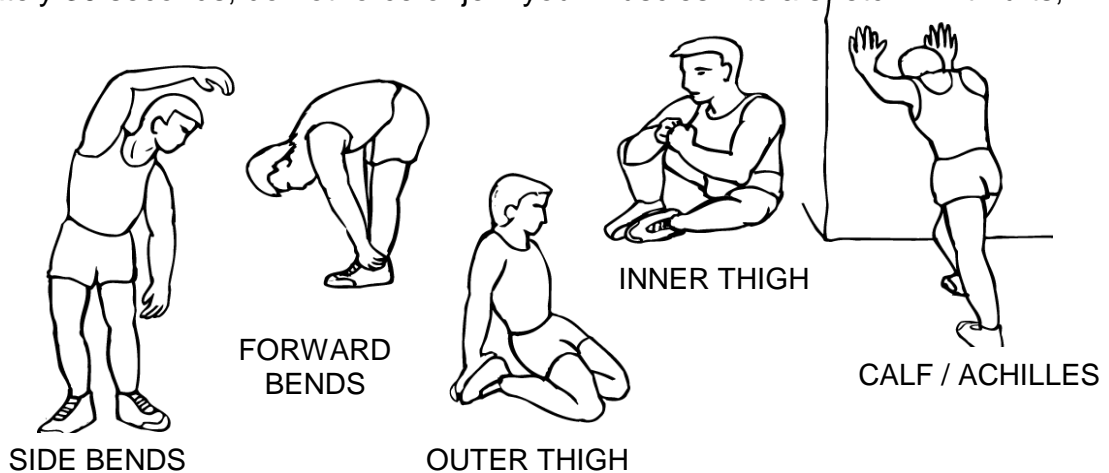

2. The Exercise Phase

This is the stage where you put the effort in. After regular use, the muscles in your legs will become more flexible. Work to your but it is very important to maintain a steady tempo throughout. The rate of work should be sufficient to raise your heartbeat into the target zone shown on the graph below.

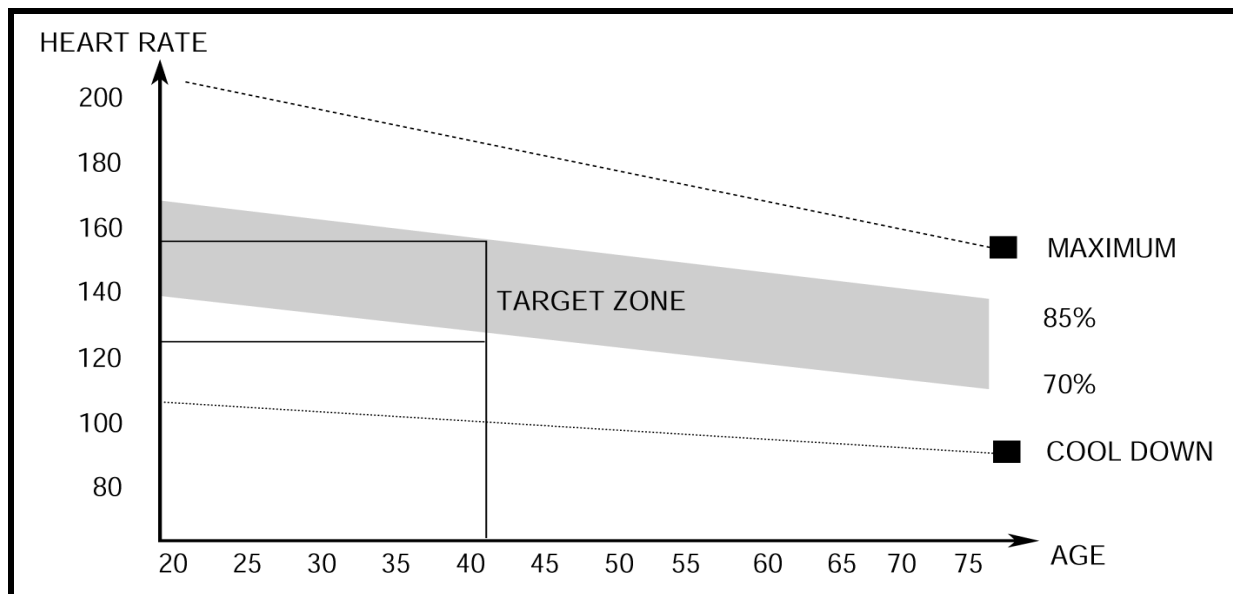

This stage should last for a minimum of 12 minutes though most people start at about 15-20 minutes

3. The Cool Down Phase

This stage is to let your Cardio-vascular System and muscles wind down. This is a

repeat of the warm up exercise e.g. reduce your tempo, continue for approximately 5 minutes. The stretching exercises should now be repeated, again remembering not to force or jerk your muscles into the stretch.

As you get fitter you may need to train longer and harder. It is advisable to train at least three times a week, and if possible space your workouts evenly throughout the week.

MUSCLE TONING

To tone muscle while on your **FOLDABLE BIKE** you will need to have the resistance set quite high. This will put more strain on our leg muscles and may mean you cannot train for as long as you would like. If you are also trying to improve your fitness you need to alter your training program. You should train as normal during the warm up and cool down phases, but towards the end of the exercise phase you should increase resistance making your legs work harder. You will have to reduce your speed to keep your heart rate in the target zone.

WEIGHT LOSS

The important factor here is the amount of effort you put in. The harder and longer you work the more calories you will burn. Effectively this is the same as if you were training to improve your fitness, the difference is the goal.

Operating Notes

1. Set up and operate the bike on a solid level surface.
2. Inspect and tighten all parts each time before using the bike. Replace any worn parts immediately. Use parts only from manufacturer to maintain/repair the bike.
3. Inspect and test all features and functions before using the bike.
4. Review all warning notices before using the bike.
5. Electronic warning notices may be obtained by contacting customer support (support@impex-fitness.com).
6. Allow minimum 20" of clear spaces in all directions to operate the bike.
7. Before mounting or dismounting move the pedal on the mounting or dismounting side to its lowest position and bring the bike to a complete stop.
8. Do not attempt to stop the spinning pedal by feet abruptly. Gradually reduce the speed of spinning pedal until it is completely stopped.
9. Pull out the Safety-pin, fold up the Main Frame from X position, insert back the Safety-pin to lock the Main Frame in fold up position to transport.
10. Store the bike in dry and cool storage area when not in use.

IMPEX[®] INC.

LIMITED WARRANTY

IMPEX Inc. ("IMPEX®") warrants this product to be free from defects in workmanship and material, under normal use and service conditions, for a period of two years on the Frame from the date of purchase. This warranty extends only to the original purchaser. IMPEX's obligation under this Warranty is limited to replacing or repairing, at IMPEX's option.

All returns must be pre-authorized by IMPEX. Pre-authorization may be obtained by calling IMPEX Customer Service Department at 1-800-999-8899. All freights for products return to IMPEX must be prepaid by the customer. This warranty does not extend to any product or damage to a product caused by or attributable to freight damage, abuse, misuse, improper or abnormal usage or repairs not provided by an IMPEX authorized service center or for products used for commercial or rental purposes. No other warranty beyond that specifically set forth above is authorized by IMPEX.

IMPEX is not responsible or liable for indirect, special or consequential damages arising out of or in connection with the use or performance of the product or other damages with respect to any economic loss, loss of property, loss of revenues or profits, loss of enjoyments or use, costs of removal, installation or other consequential damages or whatsoever natures. Some states do not allow the exclusion or limitation of incidental or consequential damages. Accordingly, the above limitation may not apply to you.

The warranty extended hereunder is in lieu of any and all other warranties and any implied warranties of merchantability or fitness for a particular purpose is limited in its scope and duration to the terms set forth herein. Some states do not allow limitations on how long an implied warranty lasts. Accordingly, the above limitation may not apply to you.

This warranty gives you specific legal right. You may also have other rights which vary from state to state. **Register on-line www.marcypro.com**

IMPEX® INC.
2801 S. Towne Ave, Pomona
Pomona, CA 91766

ORDERING REPLACEMENT PARTS

Replacement parts can be ordered by calling our Customer Service Department toll-free at **1-800-999-8899** during our regular business hours: Monday through Friday, 9 am until 5 pm Pacific standard time.
support@impex-fitness.com

When ordering replacement part, always give the following information.

1. Model
2. Description of Parts
3. Part Number
4. Date of Purchase