

NOTE:
Please read all instructions
carefully before using this
product

Safety Notice

Hardware Identifier

Assembly Instruction

Parts List

Resistance Chart

Warranty

Ordering Parts

Model
PH 1300

Retain This
Manual for
Reference

07-26-01

OWNER'S
MANUAL

IMPEx
FITNESS PRODUCTS

POWERHOUSE HOME GYM

PH 1300

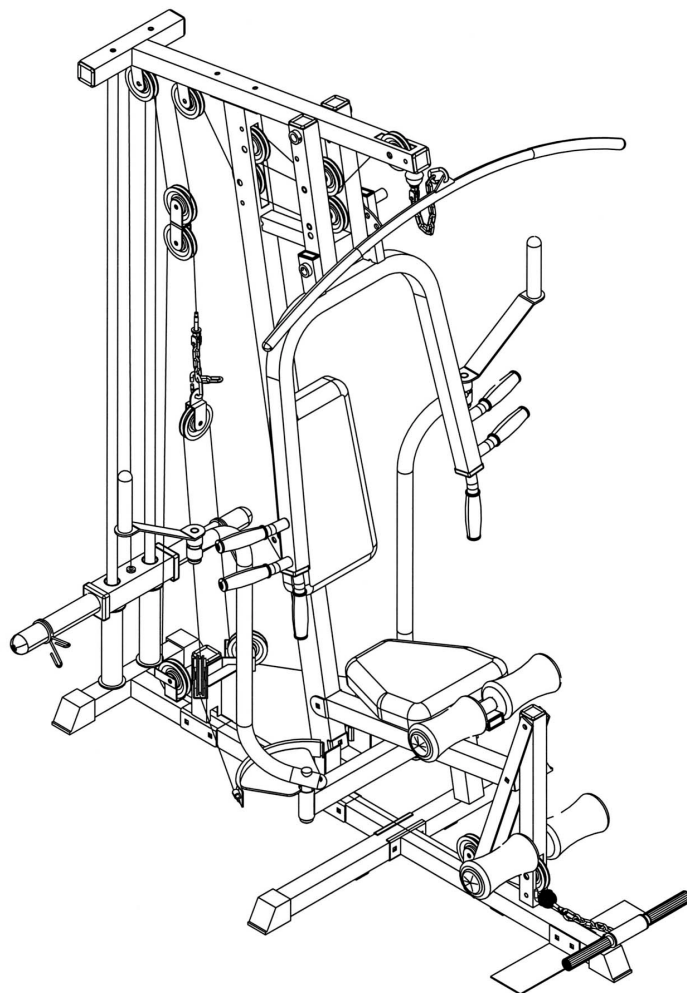

IMPEX FITNESS PRODUCTS

14777 DON JULIAN RD., CITY OF INDUSTRY, CA 91746

Tel: (800) 999-8899 Fax: (626) 961-9966

www.impex-fitness.com

info@impex-fitness.com

TABLE OF CONTENTS

BEFORE YOU BEGIN.....	1
IMPORTANT SAFETY NOTICES.....	2
HARDWARE IDENTIFIER.....	3
ASSEMBLY INSTRUCTIONS.....	4
HOW TO USE.....	17
PARTS LIST.....	18
RESISTANCE CHART.....	19
WARRANTY.....	20
ORDERING PARTS.....	20

BEFORE YOU BEGIN

Thank you for selecting the POWERHOUSE PH1300 HOME GYM by IMPEX FITNESS PRODUCTS. For your safety and benefit, read this manual carefully before using the machine. As a manufacturer, we are committed to provide you complete customer satisfaction. If you have any questions, or find there are missing or damaged parts, we guarantee you complete satisfaction through direct assistance from our factory. To avoid unnecessary delays, *please call our TOLL-FREE customer service number.* Our Customer Service Agents will provide immediate assistance to you.

Toll-Free Customer Service Number

1-800-999-8899

Mon. - Fri. 9 a.m. - 5 p.m. PST

www.impex-fitness.com

info@impex-fitness.com

IMPORTANT SAFETY NOTICE

PRECAUTIONS

This exercise machine is built for optimum safety. However, certain precautions apply whenever you operate a piece of exercise equipment. Be sure to read the entire manual before you assemble or operate your machine. In particular, note the following safety precautions:

1. **Keep children and pets away from the machine at all times. DO NOT leave children unattended in the same room with the machine.**
2. Only one person at a time should use the machine.
3. If the user experiences dizziness, nausea, chest pain, or any other abnormal symptoms, STOP the workout at once. CONSULT A PHYSICIAN IMMEDIATELY.
4. Position the machine on a clear, leveled surface. DO NOT use the machine near water or outdoors.
5. Keep hands away from all moving parts.
6. Always wear appropriate workout clothing when exercising. DO NOT wear robes or other clothing that could become caught in the machine. Running or aerobic shoes are also required when using the machine.
7. Use the machine only for its intended use as described in this manual. DO NOT use attachments not recommended by the manufacturer.
8. Do not place any sharp object around the machine.
9. Disabled person should not use the machine without a qualified person or physician in attendance.
10. Before using the machine to exercise, always do stretching exercises to properly warm up.
11. Never operate the machine if the machine is not functioning properly.

WARNING: BEFORE BEGINNING ANY EXERCISE PROGRAM, CONSULT YOUR PHYSICIAN. THIS IS ESPECIALLY IMPORTANT FOR INDIVIDUALS OVER THE AGE OF 35 OR PERSONS WITH PRE-EXISTING HEALTH PROBLEMS. READ ALL INSTRUCTIONS BEFORE USING ANY FITNESS EQUIPMENT. IMPEX INC. ASSUMES NO RESPONSIBILITY FOR PERSONAL INJURY OR PROPERTY DAMAGE SUSTAINED BY OR THROUGH THE USE OF THIS PRODUCT.

SAVE THESE INSTRUCTIONS.

HARDWARE IDENTIFIER

PLACE WASHER, END OF BOLT, OR SCREW ON CIRCLE TO CHECK FOR CORRECT SIZE.

MILLIMETERS

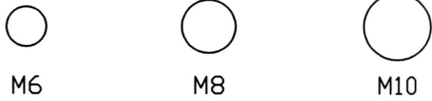

INCHES

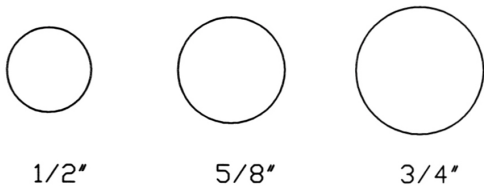

REPLACEMENT PARTS

Thank you for purchasing IMPEX product. Although we go to great effort to ensure the quality of our products, Occasionally errors or omissions occur. Should you find either a defective or missing part in this product, Please contact us for a replacement at the telephone number.

QUESTION ?



1-800-999-8899

NOTE: When installing a Aircraft Nut (also called Nylon or Lock Nut), Please use two adjustable wrenches to tighten down the Nut. Hold down the Bolt with one wrench, and use the other wrench to turn the Nut clockwise.

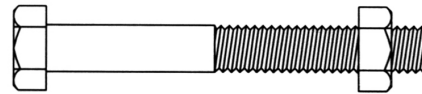
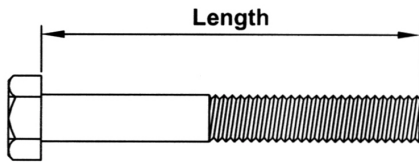

HEX HEAD BOLT

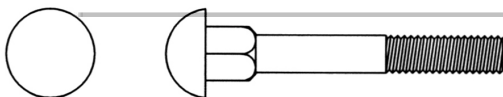

CARRIAGE BOLT



ALLEN BOLT



AIRCRAFT NUT



FLAT WASHER

ASSEMBLY INSTRUCTION

Tools Required to Assemble the Machine: Two Adjustable Wrenches, two Allen Wrenches, and one Flat Head Screwdriver

NOTE: It is strongly recommended this machine to be assembled by two or more people to avoid possible injury.

STEP 1 (See Diagram 1)

- A.) Connect the Main Base Frame (#2) and Front Base (#3) to the Front Stabilizer (#1). Align the holes then secure them with two M10 x 2 3/4" Carriage Bolts (#72), \varnothing 3/4" Washers (#87), and M10 Aircraft Nuts (#89).
- B.) Push two 2" Square End Caps (#49) onto the back ends on the Main Base Frame (#2).
- C.) Attach the Vertical Beam (#5) to the Main Base Frame (#2). Secure it with two M10 x 2 3/4" Carriage Bolts (#72), \varnothing 3/4" Washers (#87), and M10 Aircraft Nuts (#89).
- D.) Attach the Foot Plates (#92) to the Front Base (#3). Align the holes and secure it with two M10 x 2 3/4" Carriage Bolts (#72), \varnothing 3/4" Washers (#87), and M10 Aircraft Nuts (#89).

DIAGRAM 1

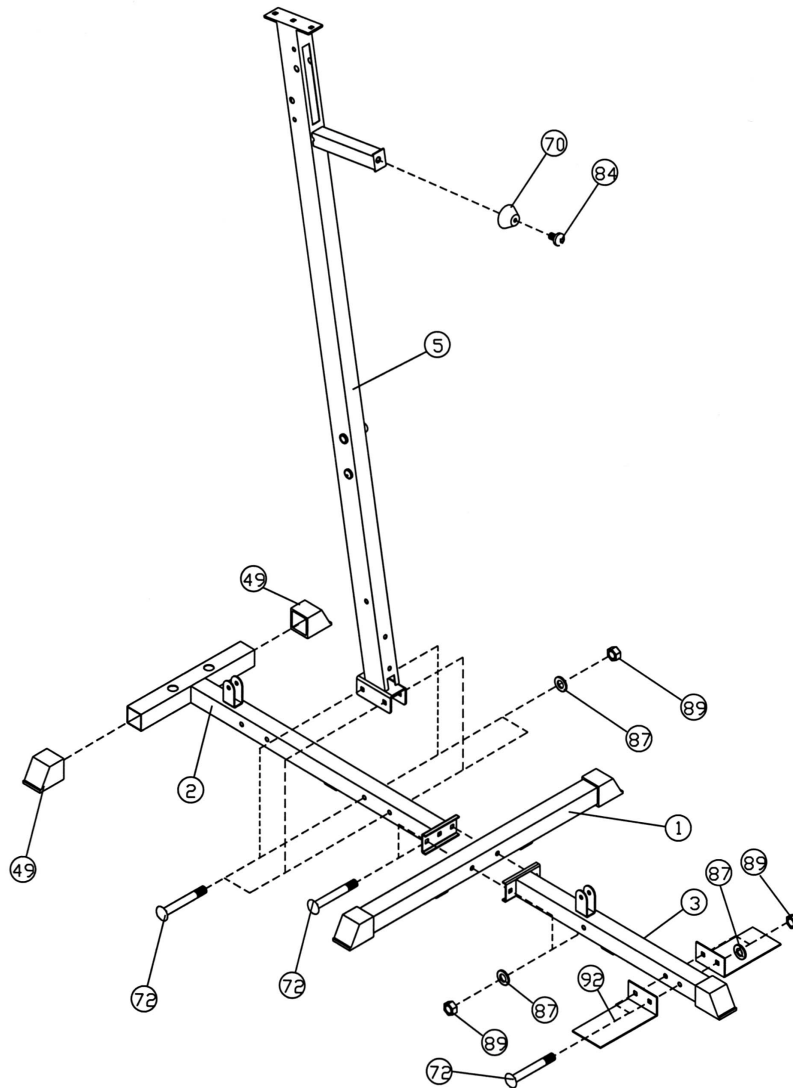

STEP 2 (See Diagram 2)

- A.) Place two Weight Guide Rod Sleeves (#15) on the back of the Main Base Frame (#2). Place two Rubber Bumpers (#65) on top of the two Weight Guide Rod Sleeves (#15).
- B.) Place the Weight Holder (#16) on the top of the two Rubber Bumpers (#65). Insert two Guide Rods (#18) through the holes on the Weight Holder (#16), the Rubber Bumpers (#65), and the Weight Guide Rod Sleeves (#15) into the holes on the Main Base Frame (#2). Secure them with two M10 x 1" Allen Bolts (#75) and $\text{\O} \frac{3}{4}$ " Washers (#87) from the bottom.
- C.) Push two Olympic Sleeves (#37) onto each end of the post on the Weight Holder (#16) then attach two Spring Clips (#38) onto each Olympic Sleeve.

DIAGRAM 2

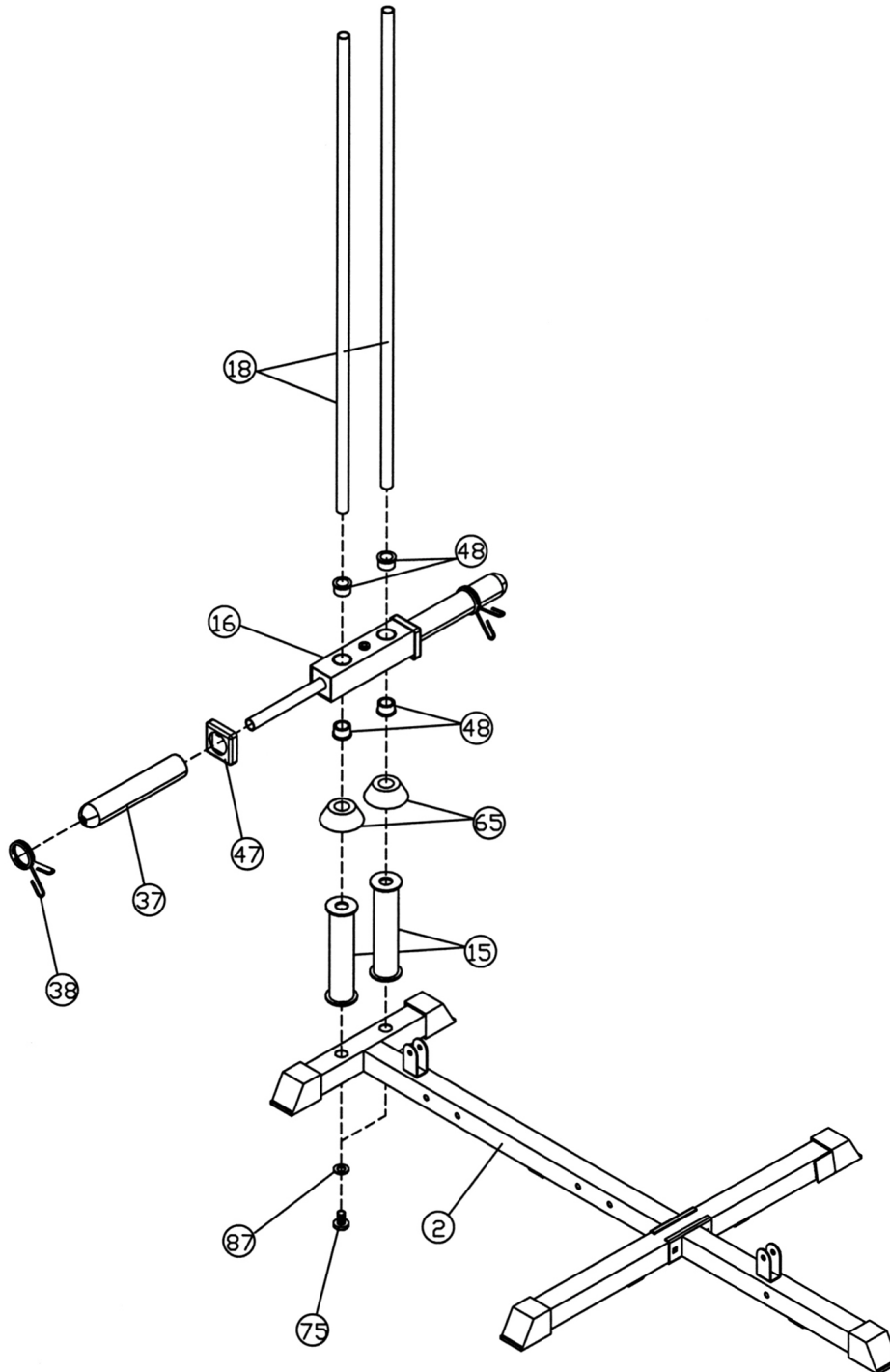

STEP 3 (See Diagram 3)

- A.) Attach the back of Upper Frame (#4) to the top of the two Guide Rods (#18). Secure it with two M10 x 1" Allen Bolts (#75) and \varnothing 3/4" Washers (#87).
- B.) Attach Upper Frame (#4) to top of Vertical Beam (#5). Secure it with one 6 1/4" Bracket (#27), two M10 x 2 3/4" Carriage Bolts (#72), \varnothing 3/4" Washers (#87), and M10 Aircraft Nuts (#89).
- C.) Attach the Backrest Board (#22) to the Backrest Support (#12). Secure it with two M8 x 1 5/8" Allen Bolts (#82) and \varnothing 5/8" Washers (#86).
- D.) Push two \varnothing 1" Bushings (#63) to the mid-lower hole on the Vertical Beam (#5) from both sides. Attach the Backrest Support (#12) to the hole. Secure it with one M12 x 3 1/2" Allen Bolt (#73), two \varnothing 1" Washers (#88), and one M12 Aircraft Nut (#90). Secure the Backrest Support with a Long Pull Pin (#43) on the Vertical Beam (#5).
- E.) Attach the Seat Support (#6) to the Vertical Beam (#5). Secure it with one M10 x 2 3/4" Carriage Bolt (#72), \varnothing 3/4" Washer (#87), and M10 Aircraft Nut (#89).

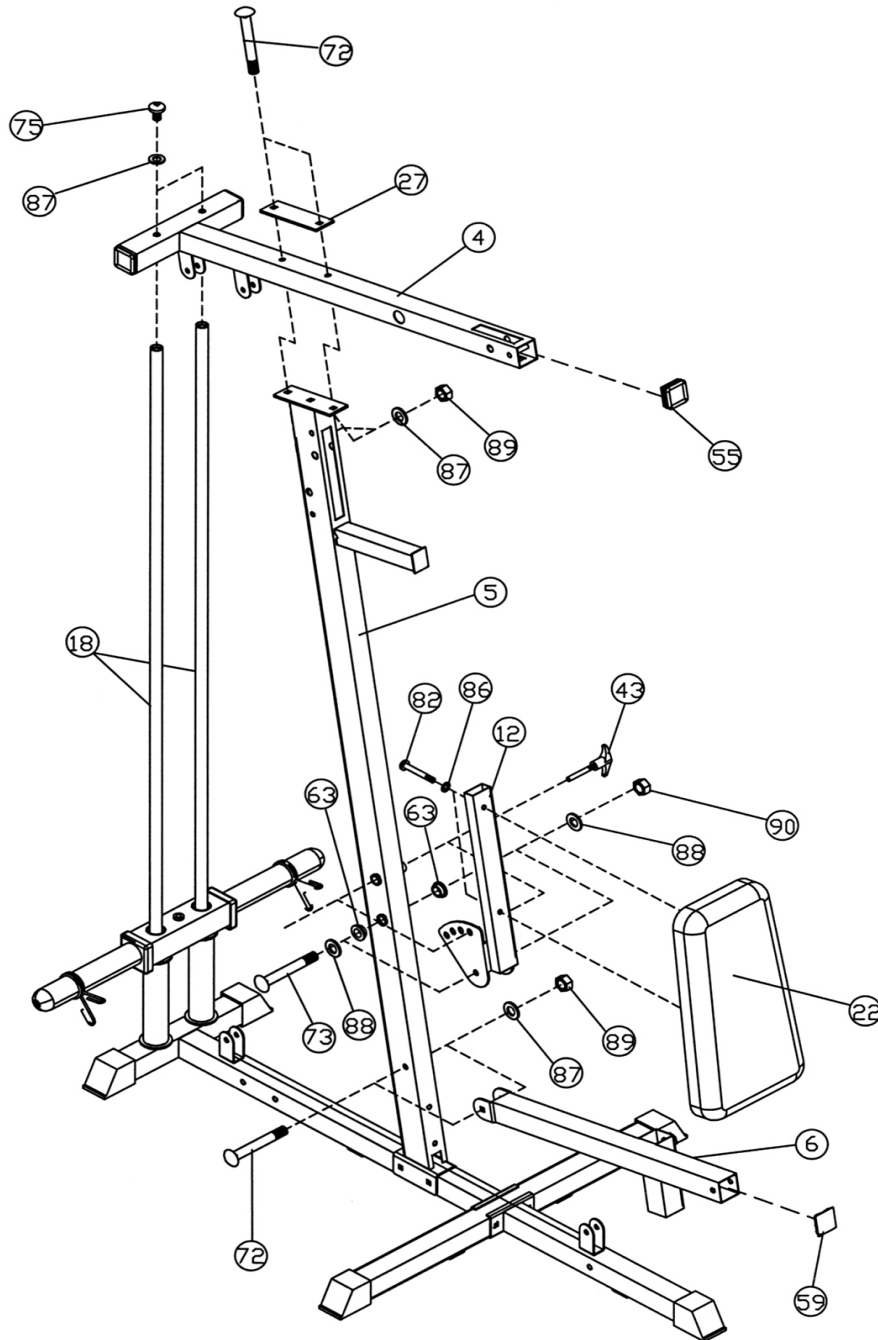

STEP 4 (See Diagram 4)

- A.) Attach two $\text{Ø}1\ 5/8"$ x $1/4"$ Bushings (#69) to the front side-holes on the Upper Frame (#4). Attach the Front Press Base (#10) to the Bushings. Align the Holes then secure it with a 7" Axle (#31) and two M6 x $1/4"$ Slotted Set Screws (#85).
- B.) Insert a M10 x $6\ 3/4"$ Allen Bolt (#77) through the upper holes on the Front Press Base (#10). Securely tighten it with two $\text{Ø}\ 3/4"$ Washers (#87) and one M10 Aircraft Nut (#89).
- C.) Attach two Front Support Frames (#7) to the Front Base (#3). Secure it with one M10 x $2\ 3/4"$ Carriage Bolt (#72), $\text{Ø}\ 3/4"$ Washer (#87), and M10 Aircraft Nut (#89).
- D.) Attach the Frames to the Seat Support (#6). Secure them with one M10 x $2\ 3/4"$ Carriage Bolt (#72), $\text{Ø}\ 3/4"$ Washer (#87), and M10 Aircraft Nut (#89).
- E.) Attach two $\text{Ø}1"$ Bushings (#63) to the Leg Developer (#8). Place the Leg Developer in between the two Support Frames. Align the holes and secure it with one M12 x 3" Allen Bolt (#74), two $\text{Ø}1"$ Washers (#88), and one M12 Aircraft Nut (#90).

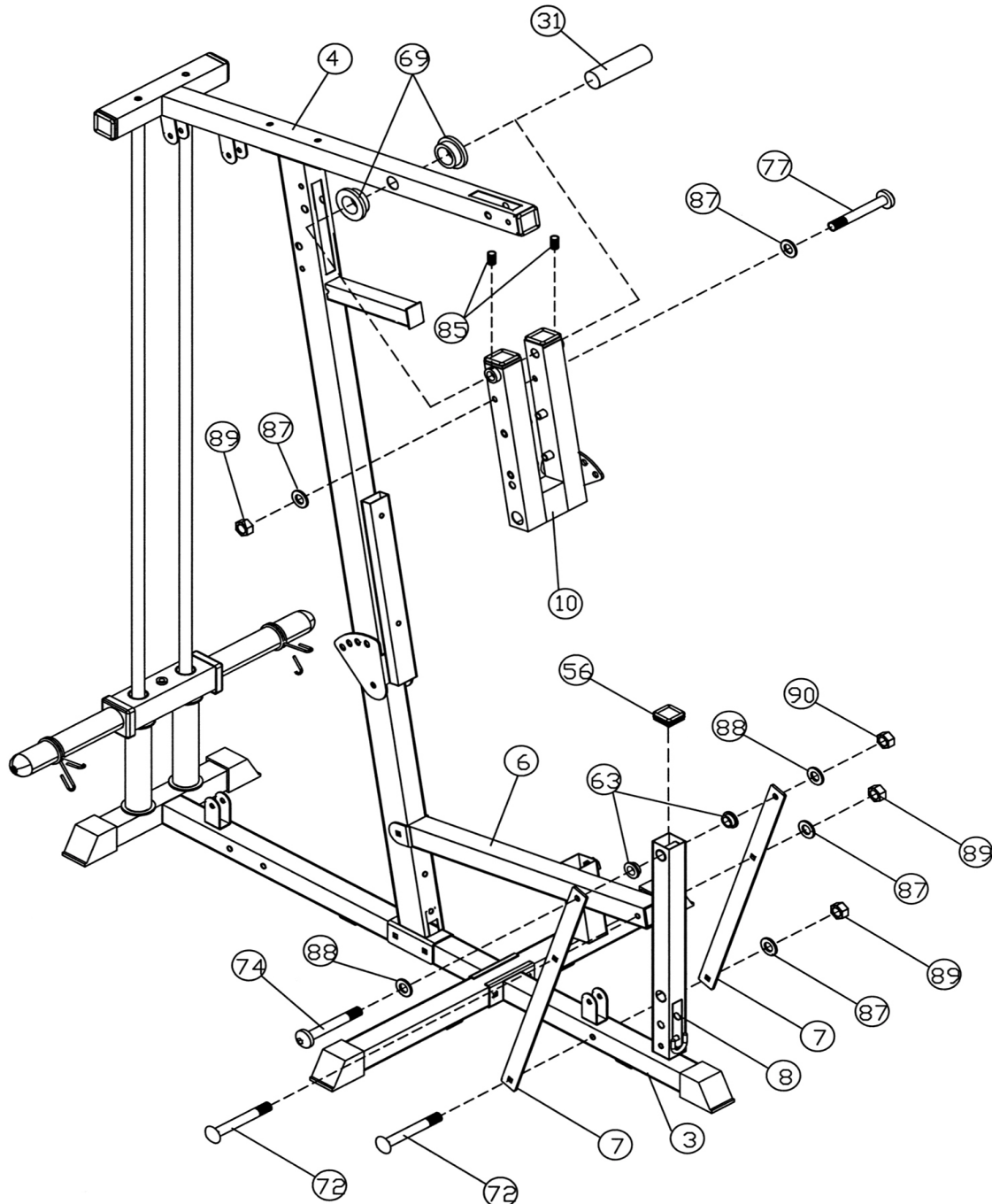

STEP 5 (See Diagram 5)

- A.) Attach two $\text{Ø}1\ 5/8'' \times 1/2''$ Bushings (#68) to the Front Press Base (#10). Attach the Front Press (#11) to the Base. Align the Holes then secure it with a M12 x 10 $3/4''$ Axle (#32), two $\text{Ø}1\ 1/4''$ Washers (#67), and two M12 Aircraft Nuts (#90). Note: Do not over tighten the nuts. Make sure the Front Press Is able to Swivel.
- B.) Secure the two M6 x $1/4''$ Slotted Set Screws (#85) on the Front Press with a Flat Head Screwdriver.
- C.) Attach the Butterfly Pulley Bracket (#17) onto the Main Base Frame (#2). Secure it with two M10 x 2 $3/4''$ Carriage Bolts (#72), $\text{Ø} 3/4''$ Washers (#87), and M10 Aircraft Nuts (#89).

DIAGRAM 5

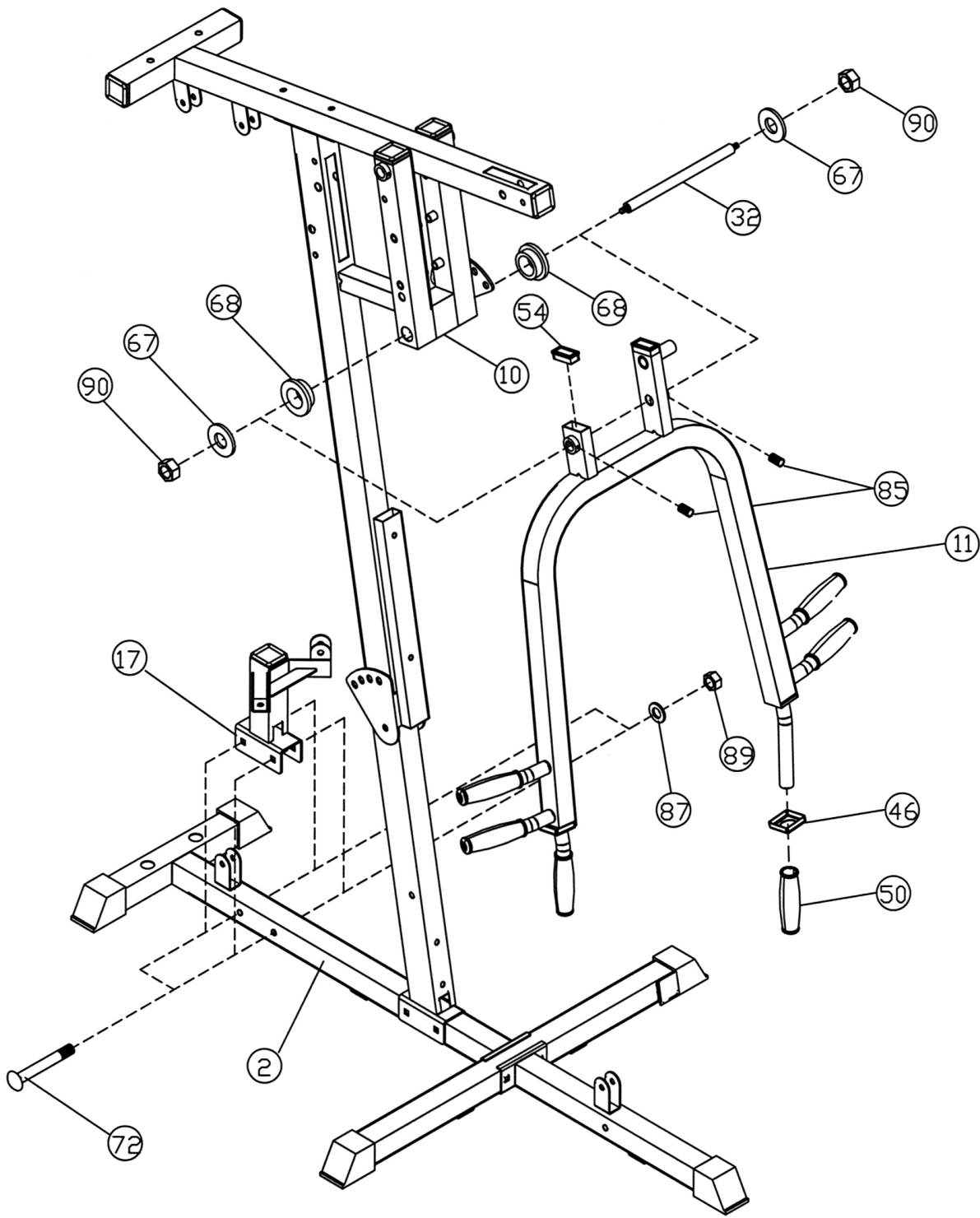

STEP 6 (See Diagram 6)

- A.) Attach the Butterfly Base (#14) to the Vertical Beam (#5). Secure it with one 4 3/4" Bracket (#26), two M10 x 3 1/2" Carriage Bolts (#71), Ø 3/4" Washers (#87), and M10 Aircraft Nuts (#89).
- B.) Insert the Right Butterfly (#20) through the right hole on the Butterfly Base. Secure it with one M12 x 5/8" Allen Bolt (#76) and Ø 1 1/2" Washer (#66). Repeat the same step to install the other side. Push 1 1/2" Round End Cap (#57) onto each end of the Butterfly.
- C.) Insert one Butterfly Handle (#13) through the pivot hole on the Right Butterfly (#20). Secure it with one M12 x 5/8" Allen Bolt (#76) and Ø 1 1/2" Washer (#66). Thread a M10 x 1" Allen Bolt (Half Thread) (#83) through the slotted hole on the pivot into the Handle. Repeat the same step to install the other side.

DIAGRAM 6

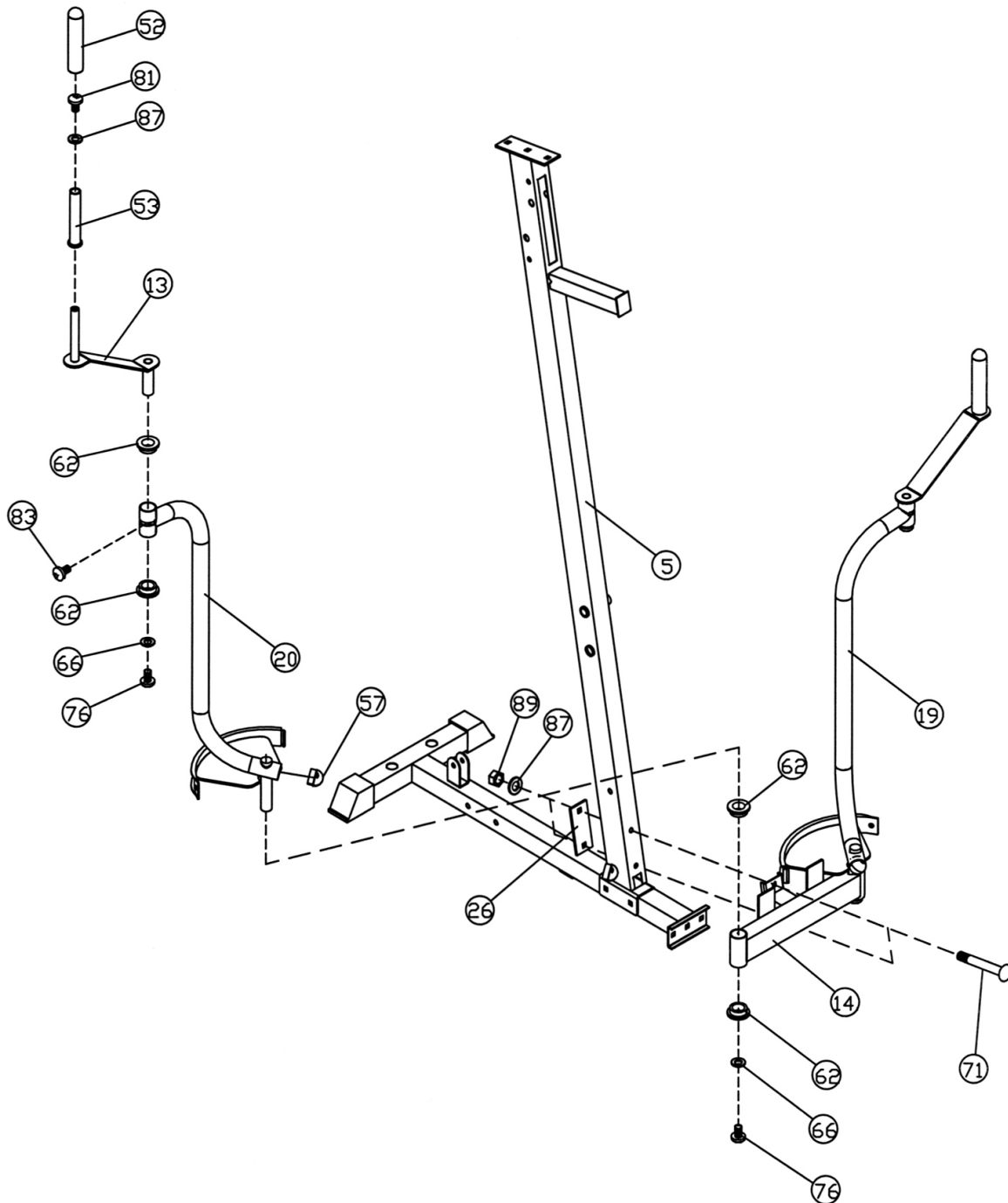

STEP 7 (See Diagram 7)

- A.) Place the Seat Pad (#21) onto the Seat Post (#9). Secure it with two M8 x 1 5/8" Allen Bolts (#82) and \varnothing 5/8" Washers (#86). Insert the Seat Post (#9) into the opening on the Seat Support (#6). Thread a Lock Knob (#44) on the Seat Support (#6) to obtain the desired height of the Seat.
- B.) Insert one Foam Roll Tube (#28) halfway through the hole on the Seat Post (#9). Insert one Foam Roll Tube (#28) halfway through the hole on the Leg Developer (#8). Push four Foam Rolls (#64) onto the Tubes. Plug four Foam Roll End Caps (#58) to the ends.

DIAGRAM 7

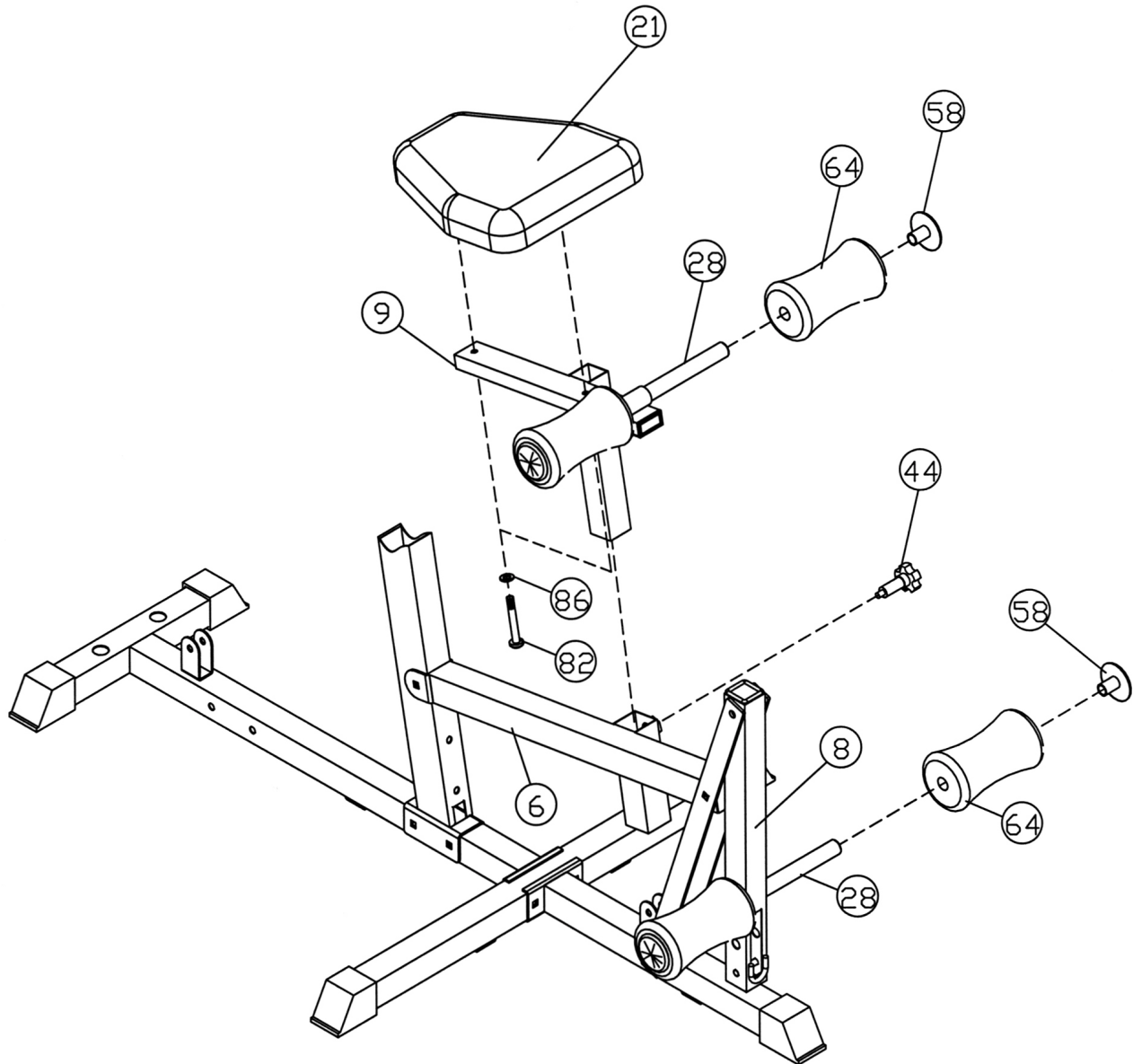

CABLE LOOP DIAGRAM

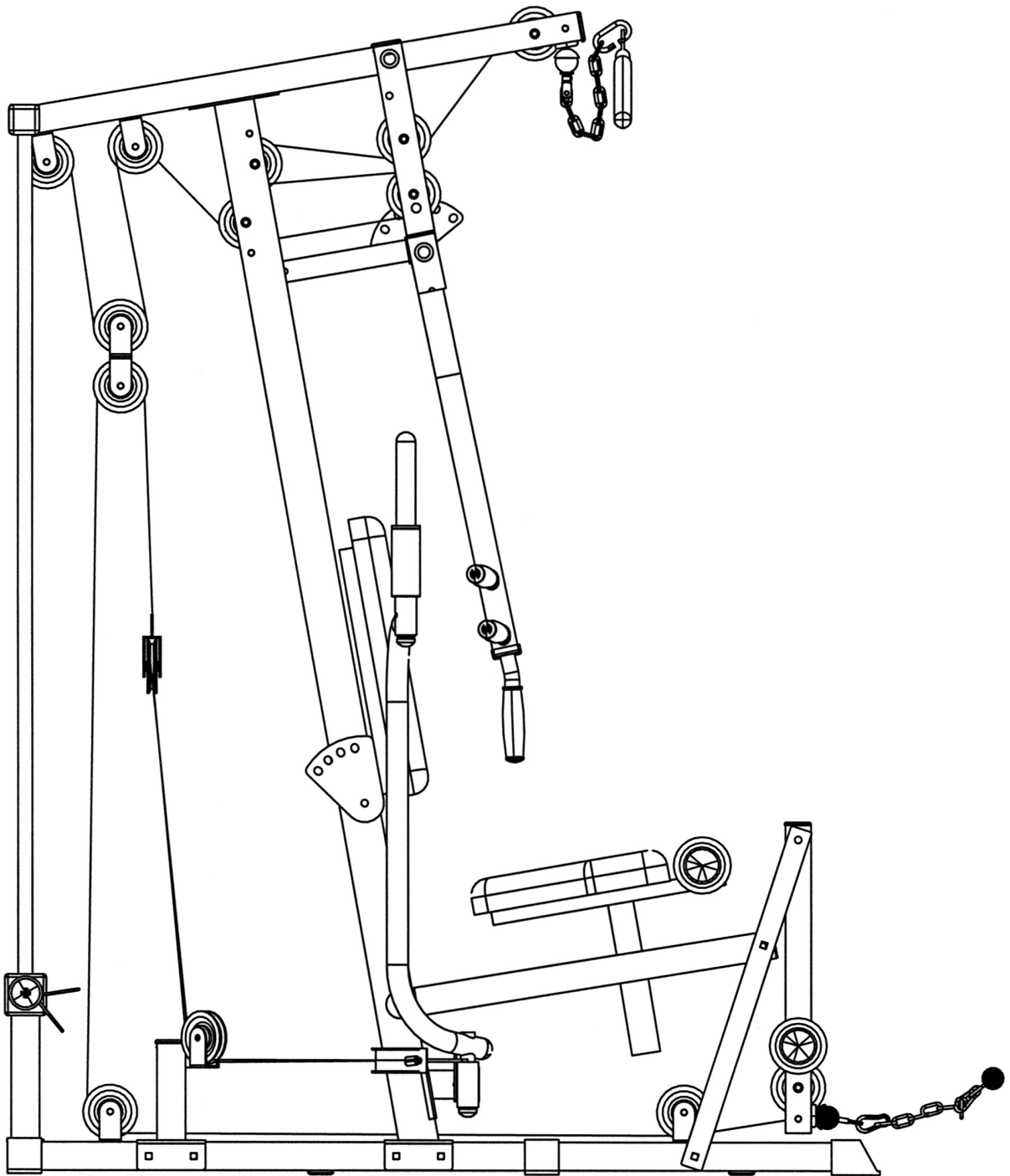

STEP 8 (See Diagram 8 & Cable Loop Diagram)

- A.) Attach the 156" Upper Cable (#34) to the opening at the front of the Upper Frame (#4). Note: the Ball Stopper on the cable should be underneath the Frame.
- B.) Attach a Pulley (#45) to the opening and secure it with one M10 x 2 ½" Allen Bolt (#78), two 5/8" Pulley Bushings (#60), and one M10 Aircraft Nut (#89).
- C.) Draw the Cable to the Front Press Base (#10). Attach a Pulley to the opening. Align the holes and secure it with a M8 x 6 ¼" Axle (#33) and two M8 x ½" Allen Bolts (#42). Draw the Cable underneath the Pulley and towards the upper opening on top of the Vertical Beam (#5).
- D.) Install a pulley as described in Step B above. Draw the Cable over the Pulley then back to the Front Press Base (#10).
- E.) Attach a Pulley to the lower opening on the Front Press Base. Secure it with a M8 x 6 ¼" Axle (#33) and two M8 x ½" Allen Bolts (#42). Pull the Cable over and around the Pulley then back to the Vertical Beam (#5).
- F.) Install another pulley to the lower opening on the Vertical Beam (#5) as described in Step B above. Draw the Cable underneath the Pulley towards the back of the machine to the first bracket on the Upper Frame (#4).
- G.) Attach a Pulley to the Bracket. Secure it with one M10 x 1 ¾" Allen Bolt (#80), two Ø ¾" Washers (#87), and one M10 Aircraft Nut (#89). Pull the Cable over the Pulley and downward.
- H.) Attach a Pulley to the Cable. Place the Pulley in between a Double Floating Pulley Bracket (#24). Secure the Pulley with one M10 x 1 ¾" Allen Bolt (#80), two Ø ¾" Washers (#87), and one M10 Aircraft Nut (#89). Let the Bracket hanging for now.
- I.) Pull the Cable upward towards the open bracket on the Upper Frame (#4) and install another Pulley. Draw the Cable over the Pulley then downward to the Weight Holder (#16). Thread the tip of the Cable into the hole on the Weight Holder.

DIAGRAM 8

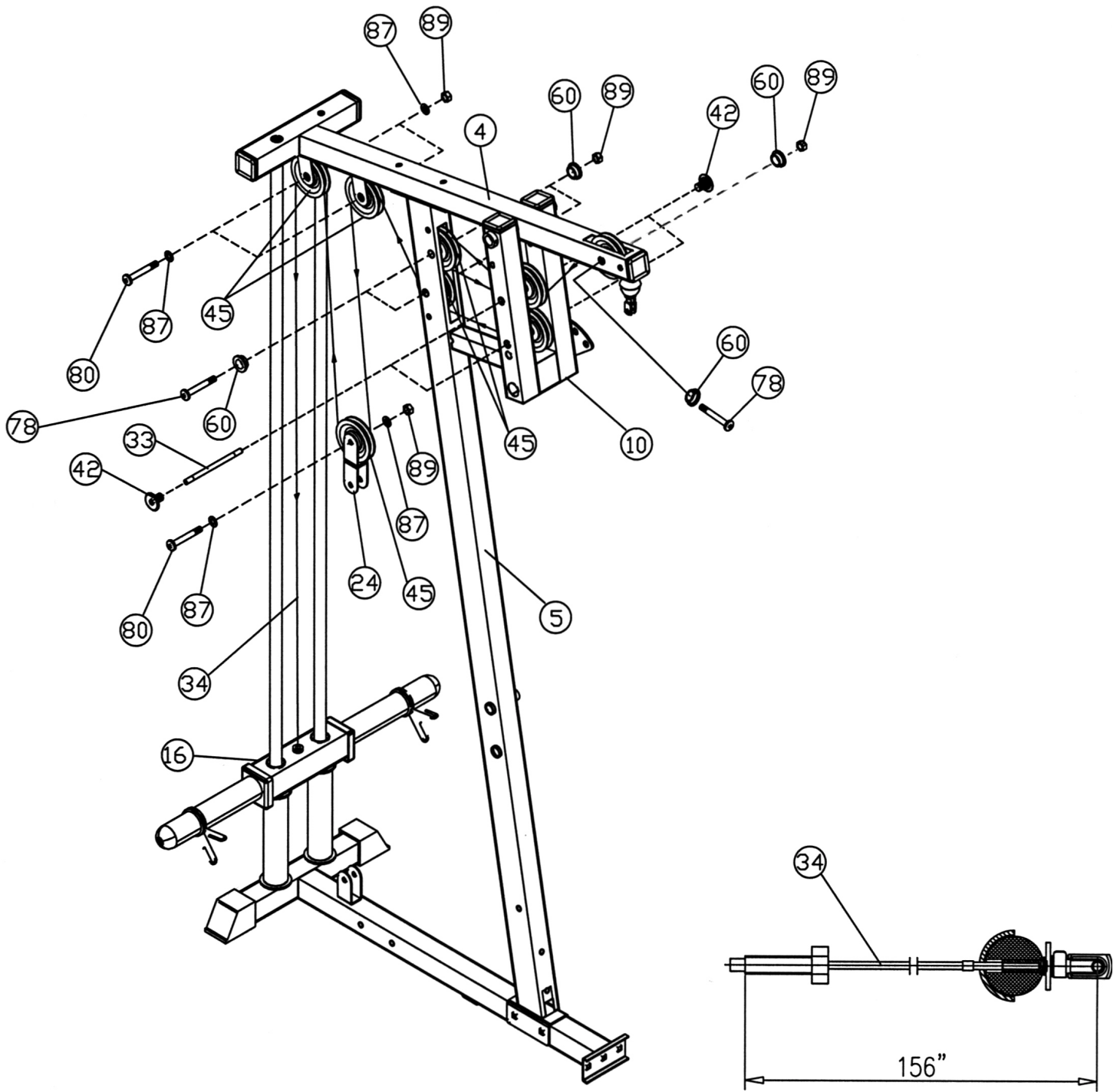

STEP 9 (See Diagram 9 & Cable Loop Diagram)

- A.) Attach the 140" Lower Cable (#36) to the opening on the Leg Developer (#8). Place a Pulley (#45) in the opening. Secure it with one M10 x 2 3/8" Allen Bolt (#79), two 1/2" Pulley Bushings (#61), and one M10 Aircraft Nut (#89).
- B.) Draw the Cable underneath the Pulley and towards the back of the machine to the open bracket on the Front Base (#3). Attach a Pulley to the Bracket then secure it with one M10 x 1 3/4" Allen Bolt (#80), two 3/4" Washers (#87), and one M10 Aircraft Nut (#89).
- C.) Draw the Cable through the opening on the bottom of Vertical Beam (#5). Continue drawing along the Main Base Frame (#2) through the opening on the Butterfly Pulley Bracket to the open bracket on the back. Attach a Pulley to the open bracket. Secure it with one M10 x 1 3/4" Allen Bolt (#80), two 3/4" Washers (#87), one 2 7/8" L-shaped Bracket (#91), and one M10 Aircraft Nut (#89).
- D.) Draw the Cable underneath the Pulley then pull upward to the Double Floating Pulley Bracket (#24) previously installed. Attach a Pulley to the Bracket and secure it with one M10 x 1 3/4" Allen Bolt (#80), two 3/4" Washers (#87), and one M10 Aircraft Nut (#89). Pull the Cable around the Pulley and downward. Connect a Short Chain (#41) to the end of the Cable. Attach the Single Floating Pulley Bracket (#23) to the Short Chain (#41) using a C-clip (#39). Let the Bracket hanging for now. Note: After completing the installation, check the tightness of the cable loop. If the cable is too loose, shorten the chain.

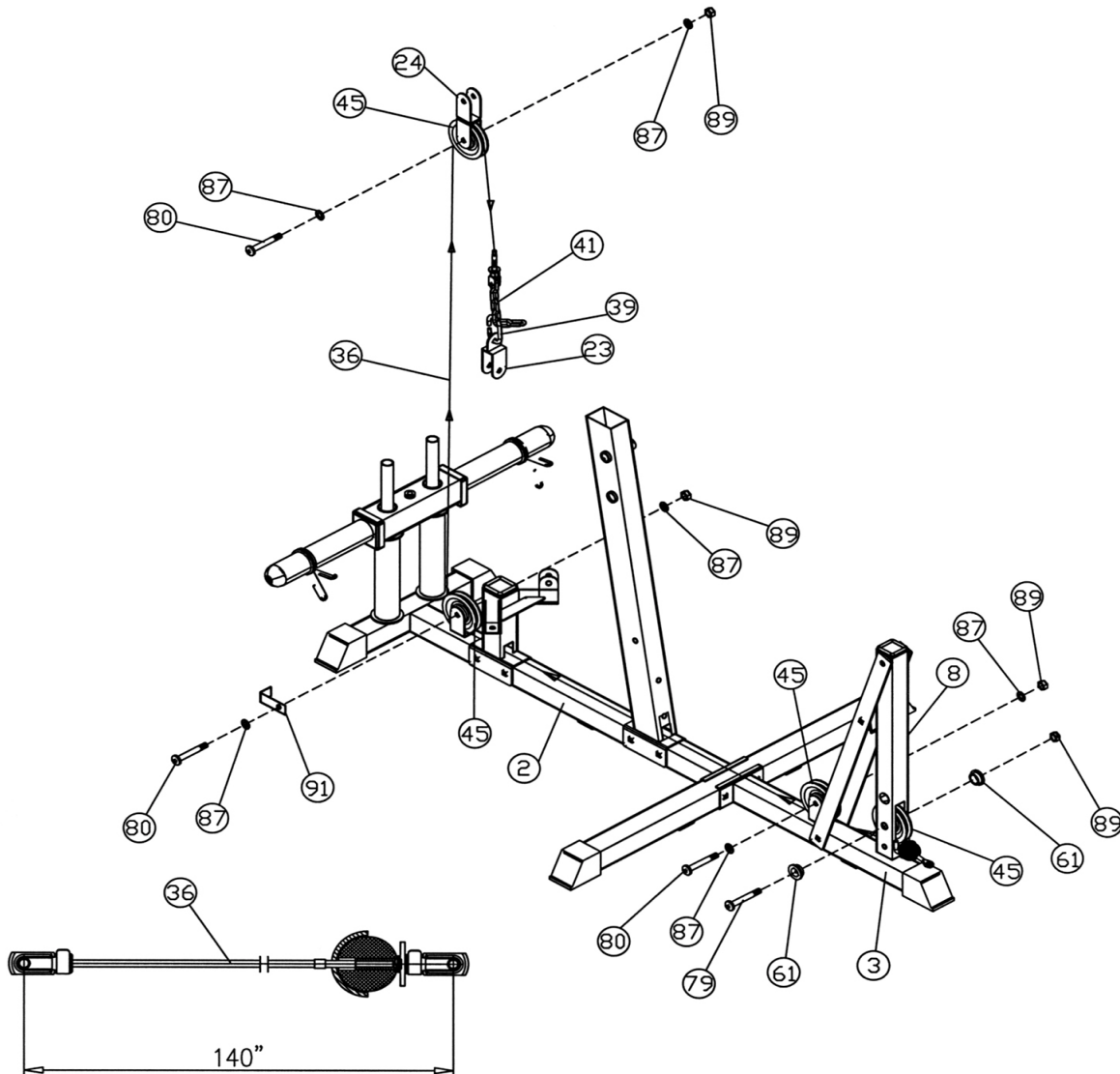

STEP 10 (See Diagram 10 & Cable Loop Diagram)

- A.) Attach one end of the 87" Butterfly Cable (#35) to the clip on the Right Butterfly (#20). Draw the Cable to the right open bracket on the Butterfly Pulley Bracket (#17).
- B.) Attach a Pulley to the Bracket and secure it with one M10 x 1 3/4" Allen Bolt (#80), two \varnothing 3/4" Washers (#87), one 2 7/8" L-shaped Bracket (#91), and one M10 Aircraft Nut (#89).
- C.) Draw the Cable underneath the Pulley then pull upward to the Single Floating Pulley Bracket (#23) previously installed in Step 9. Install another Pulley.
- D.) Pull the Cable around the Pulley then downward back to the Butterfly Pulley Bracket (#17). Repeat the procedure (B) above to install another Pulley.
- E.) Pull the Cable underneath the Pulley towards the Left Butterfly (#19). Attach the end of the Cable to the clip on the Left Butterfly (#19).

DIAGRAM 10

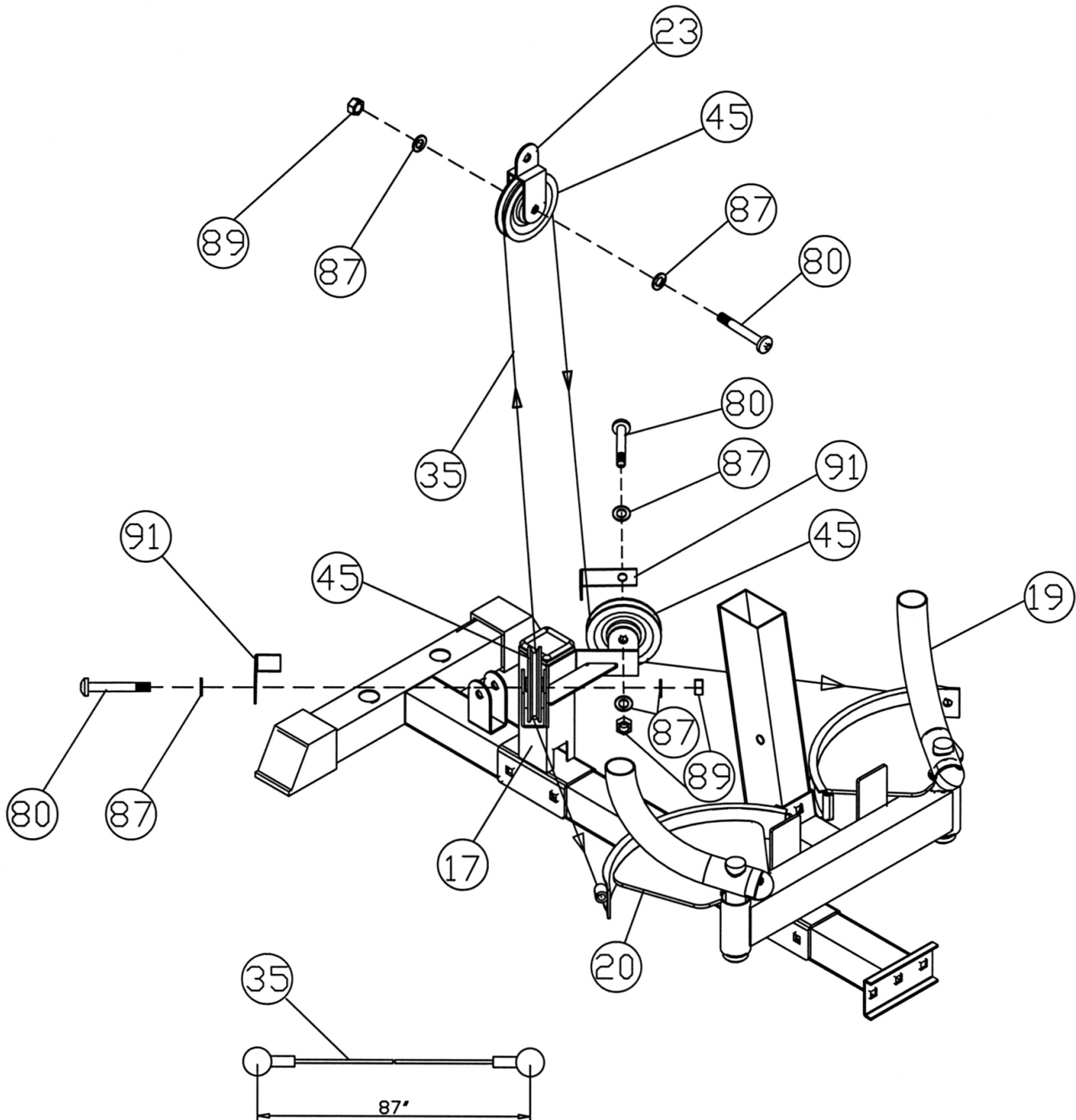

STEP 11 (See Diagram 11)

- A.) Attach a Long Chain (#40) to the Upper Cable (#34). Attach the Lat Bar (#25) to the Chain using a C-clip (#39). Adjust the length of the Chain to obtain desired Lat Bar exercise position.
- B.) Attach a Long Chain (#40) to the Lower Cable (#36). Attach the Arm Curl Handle to the Chain using a C-clip (#39). Adjust the length of the Chain to obtain the desired Arm Curl exercise position. Remove the Chain and the Handle when using the Leg Developer.

DIAGRAM 11

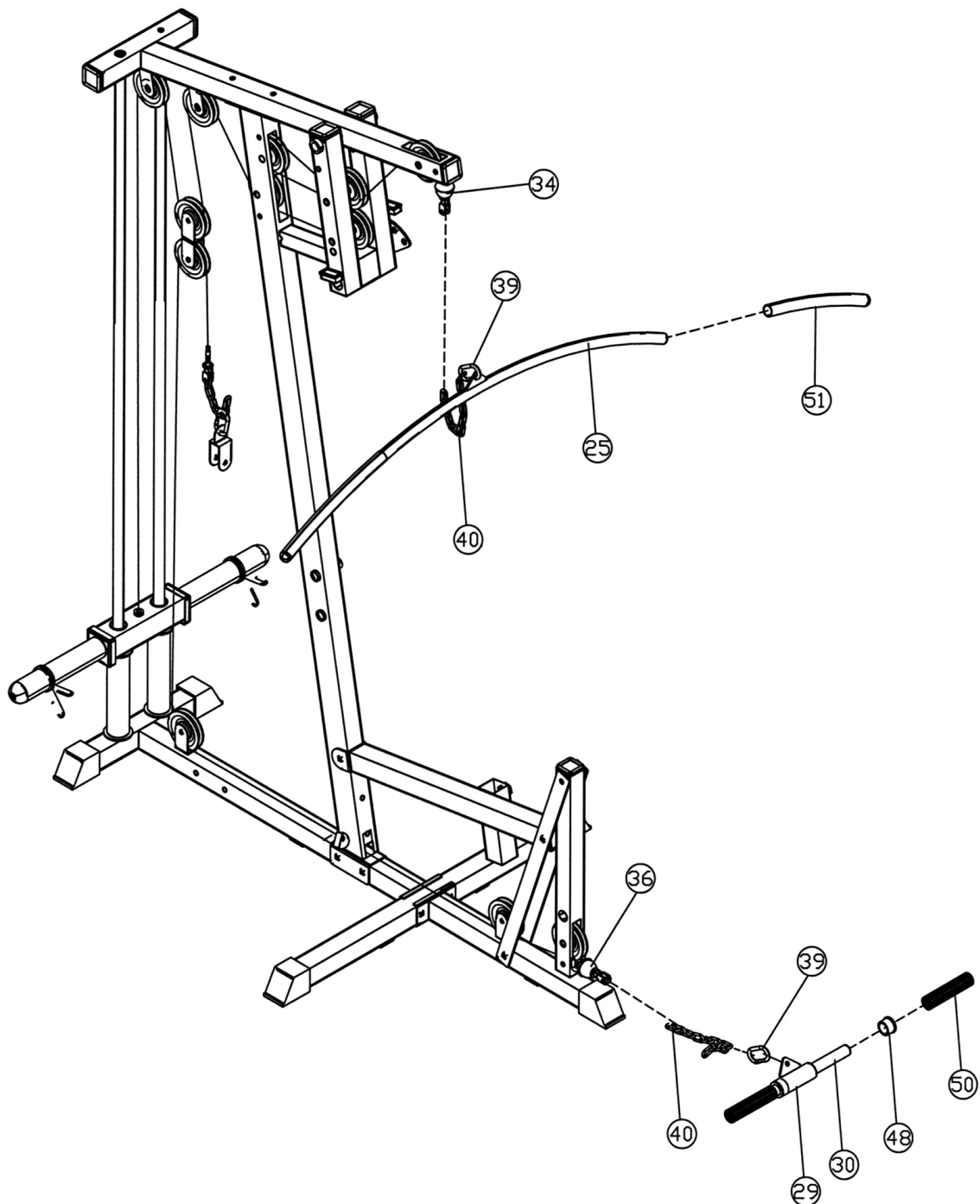

HOW TO USE

How to use the quick release connector.

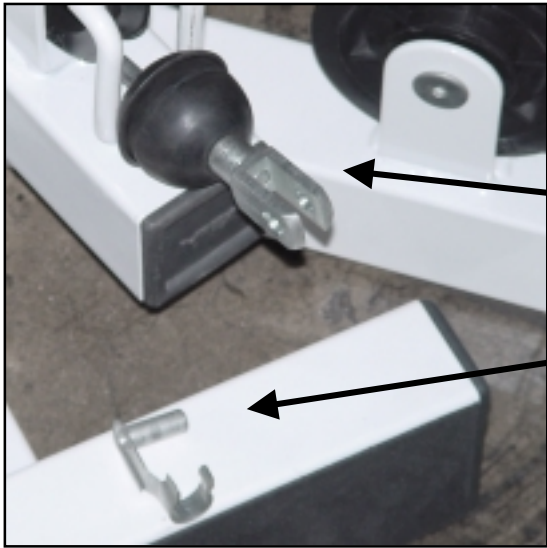

The Clip is removed from the Connector.

Connector

Clip

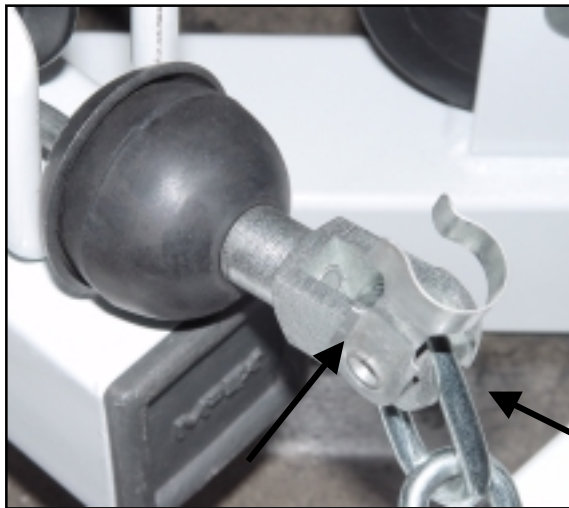

Place the chain in between the connector and insert the Clip through the holes.

Chain

Insert

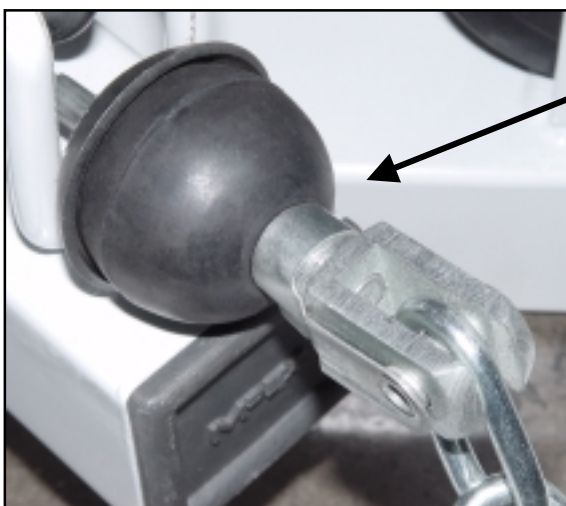

Push down the Clip to secure.

PARTS LIST

KEY NO.	DESCRIPTION	Q'ty			
1	Front Stabilizer	1	51	Lat Bar Grip	2
2	Main Base Frame	1	52	Butterfly Handle Grip	2
3	Front Base	1	53	Swivel Sleeve	2
4	Upper Frame	1	54	1" x 2" End Cap	6
5	Vertical Beam	1	55	2" End Cap (Impex Logo)	8
6	Seat Support	1	56	1 3/4" End Cap (Impex Logo)	2
7	Front Support Frame	2	57	1 1/2" Round End Cap	2
8	Leg Developer	1	58	Foam Roll End Cap	4
9	Seat Post	1	59	2" Flat End Cap	1
10	Front Press Base	1	60	5/8" Pulley Bushing	6
11	Front Press	1	61	1/2" Pulley Bushing	2
12	Backrest Support	1	62	Ø 1 1/2" Bushing	8
13	Butterfly Handle	2	63	Ø 1" Bushing	4
14	Butterfly Base	1	64	Foam Roll	4
15	Weight Guide Rod Sleeve	2	65	Rubber Bumper	2
16	Weight Holder	1	66	Ø 1 1/2" Washer	4
17	Butterfly Pulley Bracket	1	67	Ø 1 1/4" Washer	2
18	Guide Rod	2	68	Ø 1 5/8 x 1/2" Bushing	2
19	Left Butterfly	1	69	Ø 1 5/8 x 1/4" Bushing	2
20	Right Butterfly	1	70	Rubber Stopper	1
21	Seat Pad	1	71	M10 x 3 1/2" Carriage Bolt	2
22	Backrest Board	1	72	M10 x 2 3/4" Carriage Bolt	11
23	Single Floating Pulley Bracket	1	73	M12 x 3 1/2" Allen Bolt	1
24	Double Floating Pulley Bracket	1	74	M12 x 3" Allen Bolt	1
25	Lat Bar	1	75	M10 x 1" Allen Bolt	4
26	4 3/4" Bracket	1	76	M12 x 5/8" Allen Bolt	4
27	6 1/4" Bracket	1	77	M10 x 6 3/4" Allen Bolt	1
28	Foam Roll Tube	2	78	M10 x 2 1/2" Allen Bolt	3
29	Arm Curl Handle	1	79	M10 x 2 3/8" Allen Bolt	1
30	Arm Curl Handle Tube	1	80	M10 x 1 3/4" Allen Bolt	9
31	7" Axle	1	81	M10 x 5/8" Allen Bolt	2
32	M12 x 10 3/4" Axle	1	82	M8 x 1 5/8" Allen Bolt	4
33	M8 x 6 1/4" Axle	2	83	M10 x 1" Allen Bolt (Half Thread)	2
34	Upper Cable (156")	1	84	M6 x 5/8" Philips Screw	1
35	Butterfly Cable (87")	1	85	M6 x 1/4" Slotted Set Screw	4
36	Lower Cable (140")	1	86	Ø 5/8" Washer	4
37	Olympic Sleeve	2	87	Ø 3/4" Washer	41
38	Spring Clip	2	88	Ø 1" Washer	4
39	C-clip	3	89	M10 Aircraft Nut	29
40	Long Chain	2	90	M12 Aircraft Nut	4
41	Short Chain	1	91	2 7/8" L-shaped Bracket	3
42	M8 x 1/2" Allen Bolt	4	92	Foot Plate	2
43	Long Pull Pin	2			
44	Lock Knob	1			
45	Pulley	15			
46	1 3/4" Sleeve	2			
47	2 3/8" Sleeve	2			
48	Ø 1 1/2" Bushing	6			
49	2" Square End Cap	5			
50	Short Handle Grip	8			

PH 1300 WEIGHT RESISTANT TABLE

EXERCISE	RESISTANCE (% of weights installed)	EXAMPLE (60 lbs installed)
Front Press	65%	39 lbs
Butterfly (each arm)	50%	30 lbs
Leg Developer	100%	60 lbs
Lat Bar	100%	60 lbs
Arm Curl	100%	60 lbs

* Install up to 500 lbs of weights

* Numbers are approximated

IMPEX INC.

LIMITED WARRANTY

IMPEX Inc. ("IMPEX") warrants this product to be free from defects in workmanship and material, under normal use and service conditions, for a period of two years on the Frame from the date of purchase. This warranty extends only to the original purchaser. IMPEX's obligation under this Warranty is limited to replacing or repairing, at IMPEX's option.

All returns must be pre-authorized by IMPEX. Pre-authorization may be obtained by calling IMPEX Customer Service Department at 1-800-999-8899. All freights on products returned to IMPEX must be prepaid by the customer. This warranty does not extend to any product or damage to a product caused by or attributable to freight damage, abuse, misuse, improper or abnormal usage or repairs not provided by an IMPEX authorized service center or for products used for commercial or rental purposes. No other warranty beyond that specifically set forth above is authorized by IMPEX.

IMPEX is not responsible or liable for indirect, special or consequential damages arising out of or in connection with the use or performance of the product or other damages with respect to any economic loss, loss of property, loss of revenues or profits, loss of enjoyments or use, costs of removal, installation or other consequential damages or whatsoever natures. Some states do not allow the exclusion or limitation of incidental or consequential damages. Accordingly, the above limitation may not apply to you.

The warranty extended hereunder is in lieu of any and all other warranties and any implied warranties of merchantability or fitness for a particular purpose is limited in its scope and duration to the terms set forth herein. Some states do not allow limitations on how long an implied warranty lasts. Accordingly, the above limitation may not apply to you.

This warranty gives you specific legal right. You may also have other rights which vary from state to state. **Register on-line at www.impex-fitness.com**

**IMPEX INC.
14777 Don Julian
City of Industry, CA 91746**

ORDERING REPLACEMENT PARTS

Replacement parts can be ordered by calling our Customer Service Department toll-free at **1-800-999-8899** during our regular business hours: Monday through Friday, 9 am until 5 pm Pacific standard time.

info@impex-fitness.com

When ordering replacement parts, always give the following information.

1. Model
2. Description of Parts
3. Part Number
4. Date of Purchase