

NOTE:
Please read all instructions
carefully before using this
product

Table of Contents

Safety Notice

Hardware Pack

Assembly Instruction

Parts List

Warranty

Ordering Parts

Model
PL-43211

Retain This
Manual for
Reference

06-21-05

**OWNER'S
MANUAL**

MARCY

Upright Magnetic Bike

PL-43211

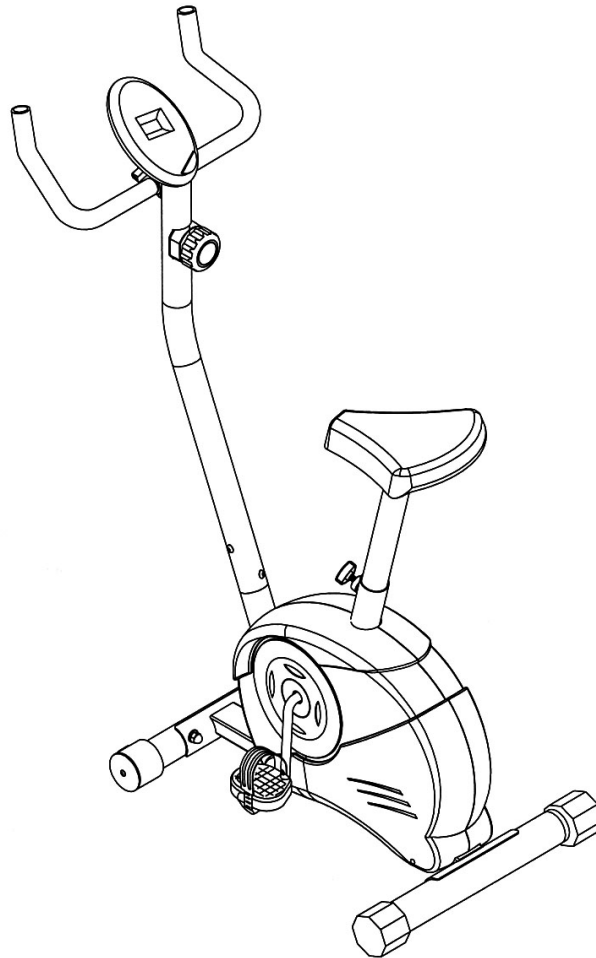

IMPEX INC.

14777 DON JULIAN RD., CITY OF INDUSTRY, CA 91746

Tel: (800) 999-8899 Fax: (626) 961-9966

www.impex-fitness.com

info@impex-fitness.com

TABLE OF CONTENTS

BEFORE YOU BEGIN.....	1
IMPORTANT SAFETY NOTICES.....	2
HARDWARE PACK.....	4
ASSEMBLY INSTRUCTIONS.....	5
EXPLODED DIAGRAM.....	9
PARTS LIST.....	10
COMPUTER.....	11
WARRANTY.....	13
ORDERING PARTS.....	13

BEFORE YOU BEGIN

Thank you for selecting the MARCY Upright Magnetic Bike PL-43211 by IMPEX INC. For your safety and benefit, read this manual carefully before using the machine. As a manufacturer, we are committed to provide you complete customer satisfaction. If you have any questions, or find there are missing or damaged parts, we guarantee you complete satisfaction through direct assistance from our factory. To avoid unnecessary delays, *please call our TOLL-FREE customer service number.* Our Customer Service Agents will provide immediate assistance to you.

<p>Toll-Free Customer Service Number 1-800-999-8899 Mon. - Fri. 9 a.m. - 5 p.m. PST www.impex-fitness.com info@impex-fitness.com</p>
--

IMPORTANT SAFETY NOTICE

PRECAUTIONS

This exercise machine is built for optimum safety. However, certain precautions apply whenever you operate a piece of exercise equipment. Be sure to read the entire manual before you assemble or operate your machine. In particular, note the following safety precautions:

1. **Keep children and pets away from the machine at all times. DO NOT leave children unattended in the same room with the machine.**
2. Only one person at a time should use the machine.
3. If the user experiences dizziness, nausea, chest pain, or any other abnormal symptoms, STOP the workout at once. CONSULT A PHYSICIAN IMMEDIATELY.
4. Position the machine on a clear, leveled surface. DO NOT use the machine near water or outdoors.
5. Keep hands away from all moving parts.
6. Always wear appropriate workout clothing when exercising. DO NOT wear robes or other clothing that could become caught in the machine. Running or aerobic shoes are also required when using the machine.
7. Use the machine only for its intended use as described in this manual. DO NOT use attachments not recommended by the manufacturer.
8. Do not place any sharp object around the machine.
9. Disabled person should not use the machine without a qualified person or physician in attendance.
10. Before using the machine to exercise, always do stretching exercises to properly warm up.
11. Never operate the machine if the machine is not functioning properly.
12. The Maximum Weight Capacity is 300 lbs.
13. Read all warnings posted on the exercise bike.
14. Inspect the exercise bike for worn or loose component prior to use.
Tighten/replace any loose or wore components prior to use.
15. Care should be taken in mounting or dismounting the exercise bike.
16. This exercise bike is for consumer and home use only.

WARNING: BEFORE BEGINNING ANY EXERCISE PROGRAM, CONSULT YOUR PHYSICIAN. THIS IS ESPECIALLY IMPORTANT FOR INDIVIDUALS OVER THE AGE OF 35 OR PERSONS WITH PRE-EXISTING HEALTH PROBLEMS. READ ALL INSTRUCTIONS BEFORE USING ANY FITNESS EQUIPMENT. IMPEX INC. ASSUMES NO RESPONSIBILITY FOR PERSONAL INJURY OR PROPERTY DAMAGE SUSTAINED BY OR THROUGH THE USE OF THIS PRODUCT.

SAVE THESE INSTRUCTIONS.

WARNING LABEL REPLACEMENT

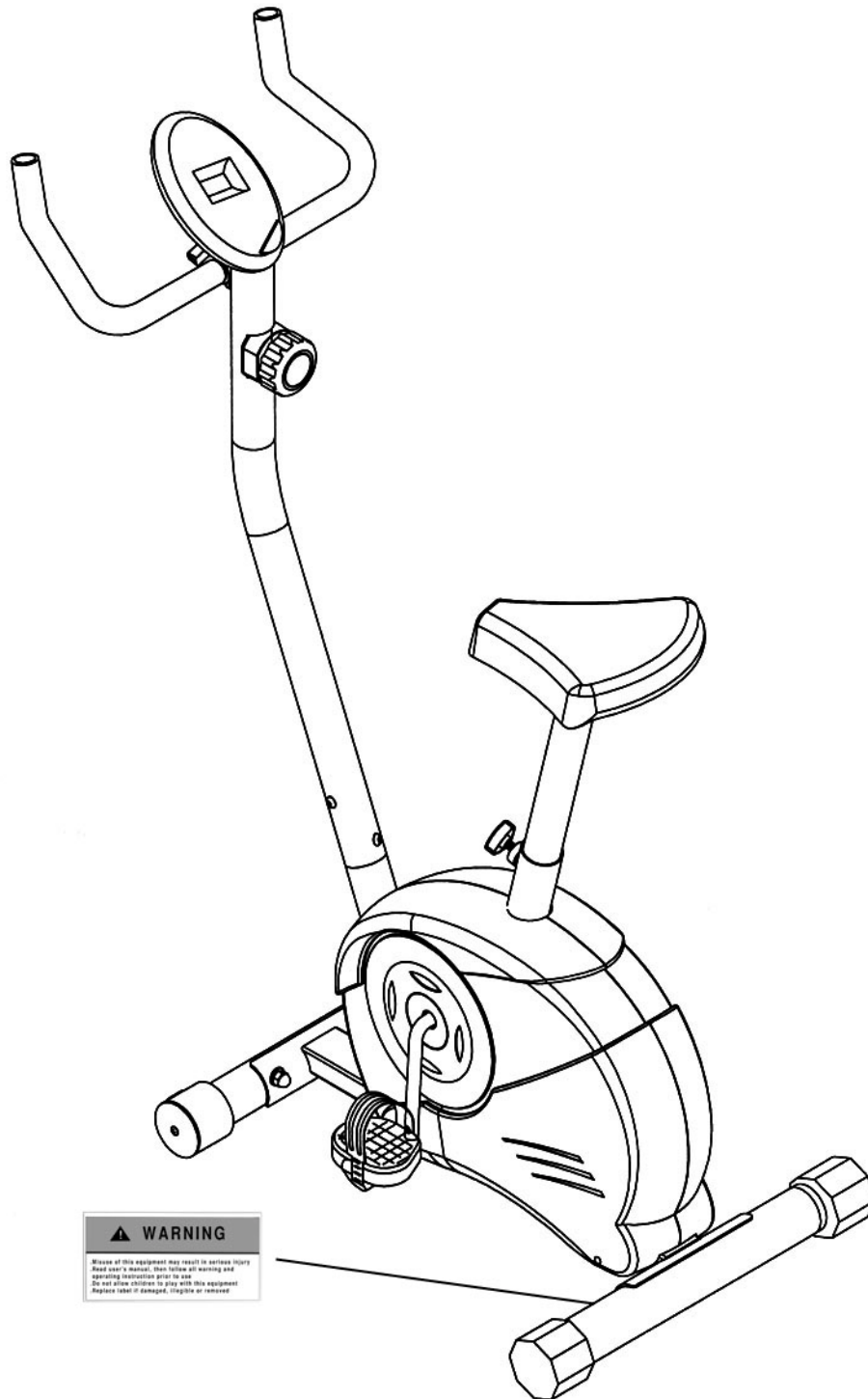

The Warning Label shown here has been placed on the Rear Stabilizer. If the label is missing or illegible, please call customer service at 1-800-999-8899 for replacement. Apply the label in location shown.

HARDWARE PACK

Part#	Description	Identifier
#15	M10 x 3" Carriage Bolt (Qty 2)	
#31	M10 x 2 3/8" Carriage Bolt (Qty 2)	
#16	Ø 1" Bent Washer (Qty 4)	
#17	M10 Acorn Nut (Qty 4)	
#19	Ø 7/8" Bent Washer (Qty 3)	
#18	M8 x 5/8" Allen Bolt (Qty 3)	
#30	Bracket (Qty 1)	
#27	M8 x 3/4" Allen Bolt (Qty 1)	
#26	T-shaped Handle Adjustment Knob (Qty 1)	
#11	Seat Post Lock Knob (Qty 1)	
Tools:		
	Allen Wrench (Qty 1)	
	Angled Wrench (Qty 1)	
	Crossing Wrench (Qty 1)	

ASSEMBLY INSTRUCTION

NOTE: It is strongly recommended two or more people assembling this machine to avoid possible injury.

STEP 1 (See Diagram1)

- A.) Attach the Rear Stabilizer (#3) to the Main Frame (#1). Secure it with two M10 x 3" Carriage Bolts (#15), \varnothing 1" Bent Washers (#16), and M10 Acorn Nuts (#17).
- B.) Attach the Front Stabilizer (#2) to the Main Frame. Secure it with two M10 x 2 3/8" Carriage Bolts (#31), \varnothing 1" Bent Washers (#16), and M10 Acorn Nuts (#17).
- C.) Plug the Roller Caps (#28) onto both ends of Front Stabilizer (#2). Plug the Rear Stabilizer End Caps (#29) onto both ends of Rear Stabilizer (#3). Set the bike firmly on a flat surface. If the surface is uneven, rotate the Rear Stabilizer End Caps to level the bike.

DIAGRAM 1

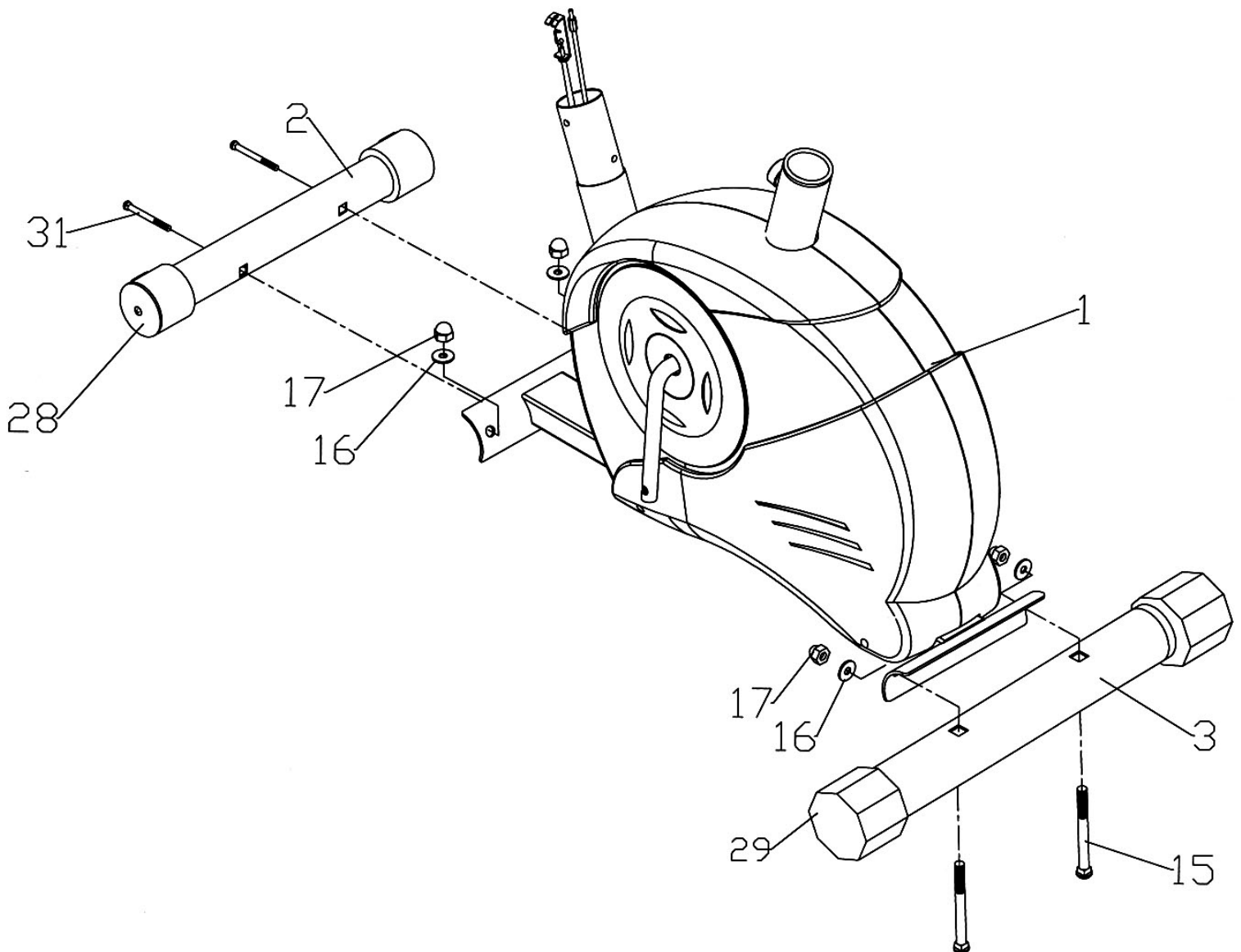

STEP 2 (See Diagram 2)

- A.) Note: In able to hold the Handlebar Post (#4) while connecting the cables and wires, extra help may be needed.
- B.) Attach the Handlebar Post (#4) to the Main Frame (#1). Connect the Middle Computer Sensor Wire (#21) from the bottom of Handlebar Post to the Lower Computer Sensor Wire (#22) from the main body of the bike.
- C.) Slide the cable wire from the Upper Tension Connector (#20) in between the opening on the wire holder on the Lower Tension Connector (#23). Pull the Upper Tension Connector upward and slide the wire through the slot on the bracket.
- D.) Drop down the Connector so the fitting sits firmly on top of the bracket.
- E.) Secure the Handlebar Post (#4) to the Main Frame (#1) with three M8 x 5/8" Allen Bolts (#18) and Ø 7/8" Bent Washers (#19).
- F.) Connect Middle Computer Sensor Wire (#21) to Upper Computer Sensor Wire (#24).
- G.) Slide the Computer (#6) onto the plate on the Handlebar Post.

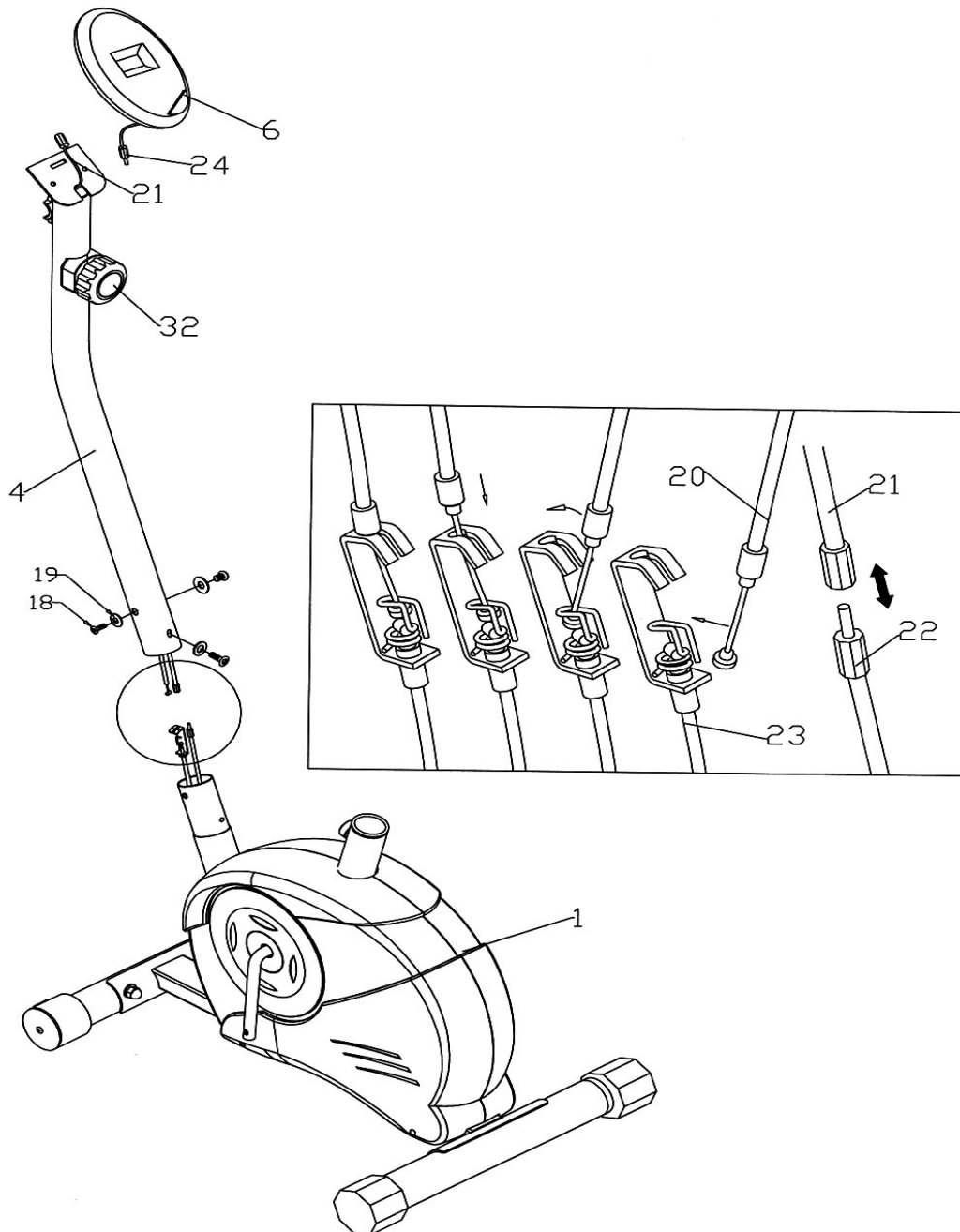

STEP 3 (See Diagram 3)

- A.) Attach the Seat (#8) to the Seat Post (#7). Secure it with three $\text{Ø } 5/8\text{''}$ Washers (#12), Spring Washers (#13), and M8 Aircraft Nuts (#14).
- B.) Insert the Seat Post into the opening on the Main Frame (#1). Use a Seat Post Lock Knob (#11) to secure the Seat Post at desired height.
- C.) Attach the Handle Bar (#5) to the Handlebar Post (#4). Secure it with a Bracket (#30), M8 x $3/4\text{''}$ Allen Bolt (#27), and a T-shaped Knob (#26). Use the Knob to adjust the position of the Handlebar.

DIAGRAM 3

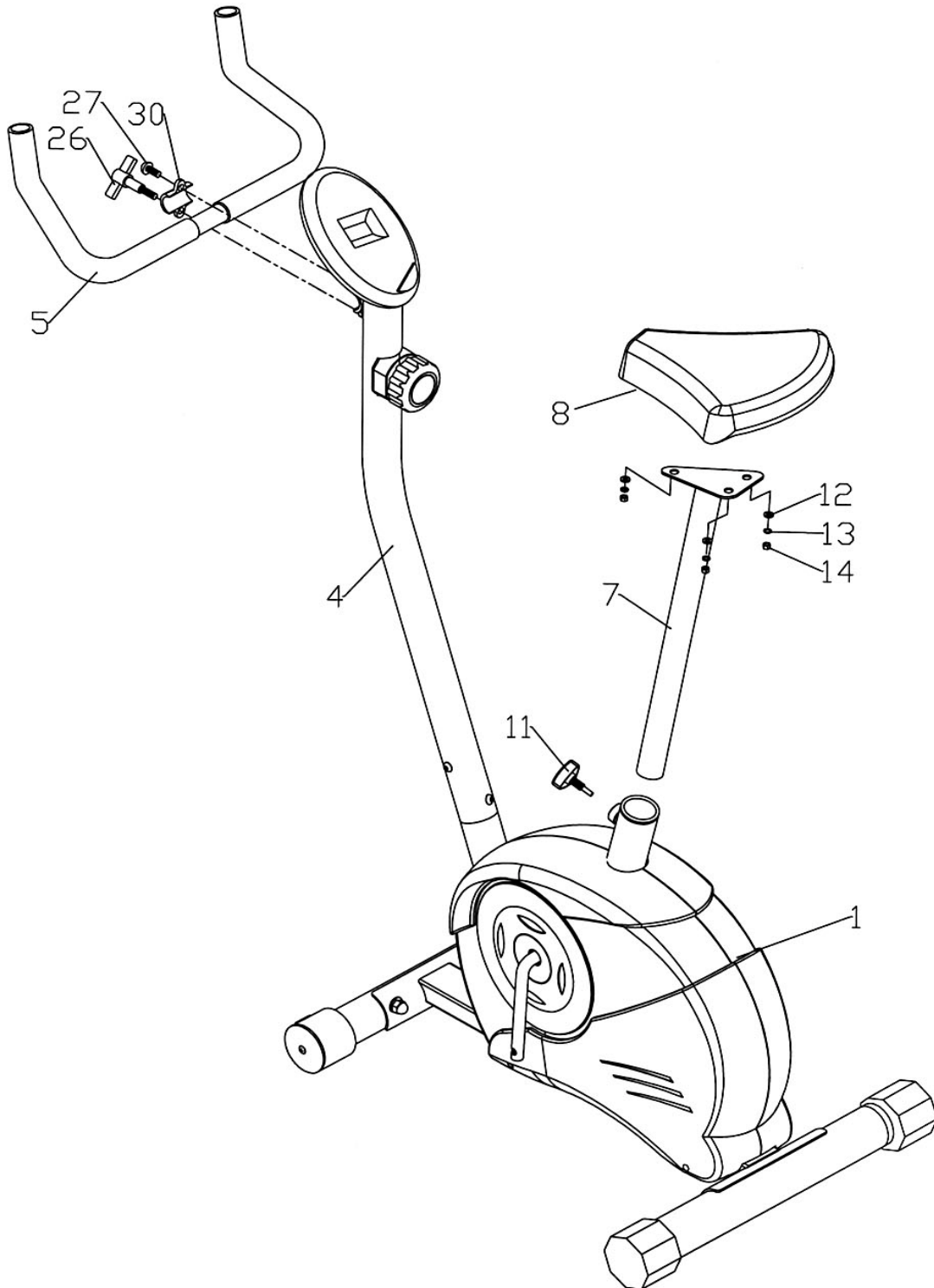

STEP 4 (See Diagram 4)

- A.) Thread the Left Pedal (#9) counterclockwise into the left Crank (#25).
Thread the Right Pedal (#10) Clockwise into the Crank on the other side.

DIAGRAM 4

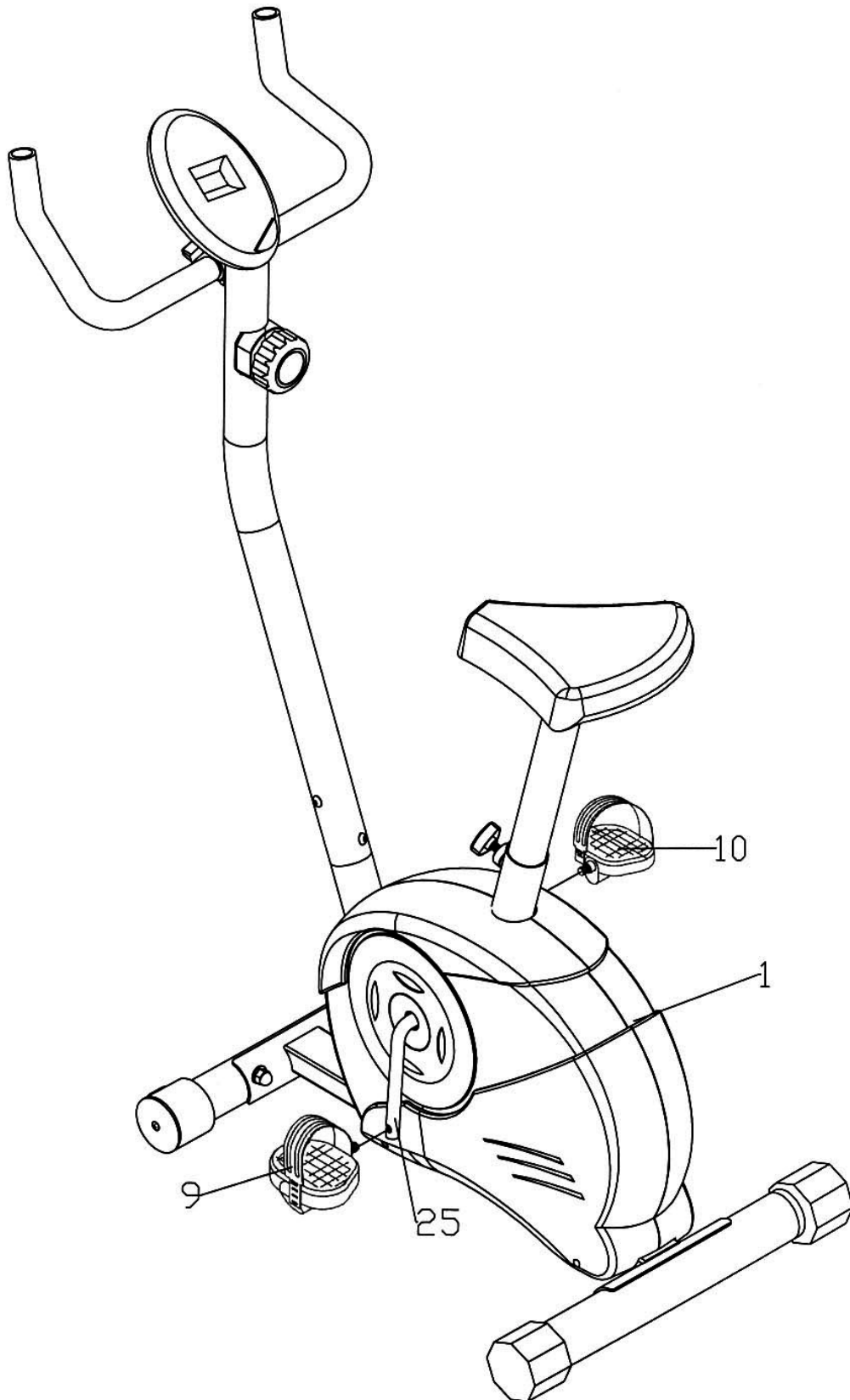

EXPLODED DIAGRAM

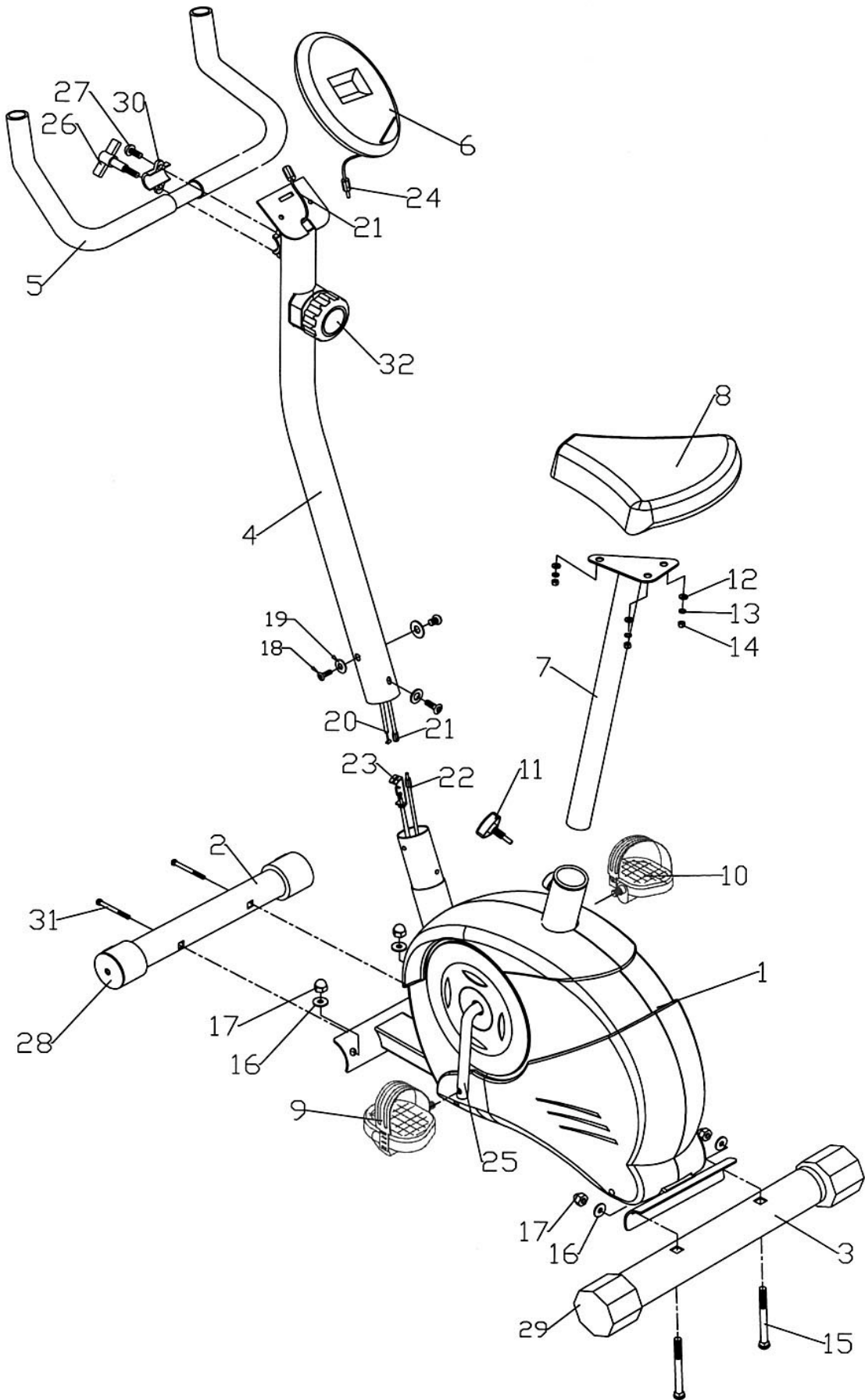

PARTS LIST

<u>KEY NO.</u>	<u>DESCRIPTION</u>	<u>QUANTITY</u>
1	Main Frame	1
2	Front Stabilizer	1
3	Rear Stabilizer	1
4	Handlebar Post	1
5	Handle Bar	1
6	Computer	1
7	Seat Post	1
8	Seat	1
9	Left Pedal	1
10	Right Pedal	1
11	Seat Post Lock Knob	1
12	Ø 5/8" Washer	3
13	Spring Washer	3
14	M8 Aircraft Nut	3
15	M10 x 3" Carriage Bolt	2
16	Ø 1" Bent Washer	4
17	M10 Acorn Nut	4
18	M8 x 5/8" Allen Bolt	3
19	Ø 7/8" Bent Washer	3
20	Upper Tension Connector	1
21	Middle Computer Sensor Wire	1
22	Lower Computer Sensor Wire	1
23	Lower Tension Connector	1
24	Upper Computer Sensor Wire	1
25	Crank	1
26	T-shaped Knob	1
27	M8 x 3/4" Allen Bolt	1
28	Roller Cap	2
29	Rear Stabilizer End Cap	2
30	Bracket	1
31	M10 x 2 3/8" Carriage Bolt	2
32	Tension Adjustment Knob	1

COMPUTER



AUTO START / STOP

When exercise starts, the monitor will automatically turn on and display the progress. When exercise stops, the monitor will automatically turn off (after 4 minutes) to save energy.

Press "MODE" key to scan Time, Speed, Distance, and Calories.

DISPLAY:

Time	Display the elapsed time. Max value is up to 99:59
Speed	Display the current speed in miles per hour.
Distance	Display the distance traveled in Miles. Max value is 99.99 miles.
Calories	Display the calorie consumption in Kcal.

REPLACE BATTERY:

1. Remove the battery cover on the back of the computer.
2. Replace two 1.5V (AA) batteries.
3. Make sure the batteries are installed correctly and the polarities are correct.
4. If the display is not clear or only partial segments appeared, remove the batteries and wait for 15 seconds before re-install them.
5. The battery life is approx. 3 months under normal usage.
6. When the batteries are removed, all the functional values will reset to zero.

Note:

Please note all values on this computer are approximate and they are for comparison purpose only. Do not use these values for any medical or rehabilitation purpose.

Maintenance and Storage

- 1. Inspect and tighten all parts each time you use the machine. Replace any worn parts immediately.**
- 2. The bike can be cleaned using a damp cloth and mild non-abrasive detergent. Do not use solvents.**
- 3. Store the machine IN-DOOR. Excess moisture and water would cause rust on the frame.**
- 4. The machine shall be placed at least 24 inches away from the wall or/and any other object such as furniture to provide safe access to and passage around the machine.**
- 5. To avoid possible injury, the help of two or more people are needed when moving the machine around.**

IMPEX INC.

LIMITED WARRANTY

IMPEX Inc. ("IMPEX") warrants this product to be free from defects in workmanship and material, under normal use and service conditions, for a period of two years on the Frame from the date of purchase. This warranty extends only to the original purchaser. IMPEX's obligation under this Warranty is limited to replacing or repairing, at IMPEX's option.

All returns must be pre-authorized by IMPEX. Pre-authorization may be obtained by calling IMPEX Customer Service Department at 1-800-999-8899. All freights for products return to IMPEX must be prepaid by the customer. This warranty does not extend to any product or damage to a product caused by or attributable to freight damage, abuse, misuse, improper or abnormal usage or repairs not provided by an IMPEX authorized service center or for products used for commercial or rental purposes. No other warranty beyond that specifically set forth above is authorized by IMPEX.

IMPEX is not responsible or liable for indirect, special or consequential damages arising out of or in connection with the use or performance of the product or other damages with respect to any economic loss, loss of property, loss of revenues or profits, loss of enjoyments or use, costs of removal, installation or other consequential damages or whatsoever natures. Some states do not allow the exclusion or limitation of incidental or consequential damages. Accordingly, the above limitation may not apply to you.

The warranty extended hereunder is in lieu of any and all other warranties and any implied warranties of merchantability or fitness for a particular purpose is limited in its scope and duration to the terms set forth herein. Some states do not allow limitations on how long an implied warranty lasts. Accordingly, the above limitation may not apply to you.

This warranty gives you specific legal right. You may also have other rights which vary from state to state. Register on-line www.impex-fitness.com

IMPEX INC.
14777 Don Julian
City of Industry, CA 91746

ORDERING REPLACEMENT PARTS

Replacement parts can be ordered by calling our Customer Service Department toll-free at **1-800-999-8899** during our regular business hours: Monday through Friday, 9 am until 5 pm Pacific standard time.
info@impex-fitness.com

When ordering replacement parts, always give the following information.

1. Model
2. Description of Parts
3. Part Number
4. Date of Purchase