

NOTE:
Please read all instructions
carefully before using this
product

Table of Contents

Safety Notice

Hardware Identifier

Assembly Instruction

Parts List

Resistance Chart

Warranty

Ordering Parts

Model
PM-3200

Retain This
Manual for
Reference

110525

OWNER'S
MANUAL

IMPEX

PLATINUM MARCY HOME GYM

PM-3200

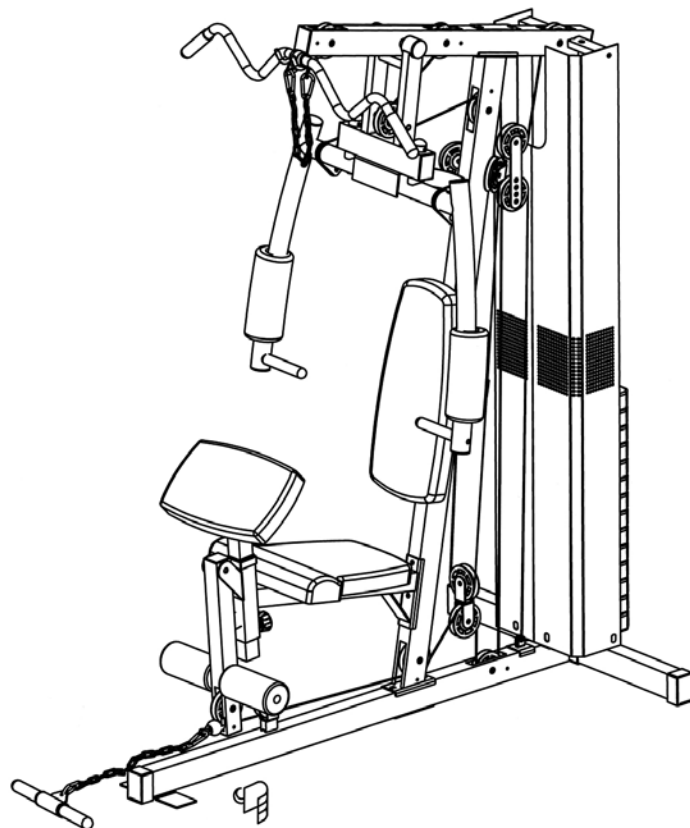

IMPEX[®] INC.

14777 DON JULIAN RD., CITY OF INDUSTRY, CA 91746

Tel: (800) 999-8899 Fax: (626) 961-9966

www.impex-fitness.com

info@impex-fitness.com

TABLE OF CONTENTS

BEFORE YOU BEGIN.....	1
IMPORTANT SAFETY NOTICES.....	2
HARDWARE PACK.....	4
ASSEMBLY INSTRUCTIONS.....	7
PARTS LIST.....	23
RESISTANCE CHART.....	24
WARRANTY.....	25
ORDERING PARTS.....	25

BEFORE YOU BEGIN

Thank you for selecting the PLATINUM MARCY PM-3200 HOME GYM by IMPEX[®] INC. For your safety and benefit, read this manual carefully before using the machine. As a manufacturer, we are committed to provide you complete customer satisfaction. If you have any questions, or find there are missing or damaged parts, we guarantee you complete satisfaction through direct assistance from our factory. To avoid unnecessary delays, *please call our TOOL-FREE customer service number*. Our Customer Service Agents will provide immediate assistance to you.

Toll-Free Customer Service Number

1-800-999-8899

Mon. – Fri. 9 a.m. – 5 p.m. PST

www.impex-fitness.com

info@impex-fitness.com

IMPORTANT SAFETY NOTICE

PRECAUTIONS

This exercise machine is built for optimum safety. However, certain precautions apply whenever you operate a piece of exercise equipment. Be sure to read the entire manual before you assemble or operate your machine. In particular, note the following safety precautions:

1. **Keep children and pets away from the machine at all times. DO NOT leave children unattended in the same room with the machine.**
2. Only one person at a time should use the machine.
3. If the user experiences dizziness, nausea, chest pain, or any other abnormal symptoms, STOP the workout at once. CONSULT A PHYSICIAN IMMEDIATELY.
4. Position the machine on a clear, leveled surface. DO NOT use the machine near water or outdoors.
5. Keep hands away from all moving parts.
6. Always wear appropriate workout clothing when exercising. DO NOT wear robes or other clothing that could become caught in the machine. Running or aerobic shoes are also required when using the machine.
7. Use the machine only for its intended use as described in this manual. DO NOT use attachments not recommended by the manufacturer.
8. Do not place any sharp object around the machine.
9. Disabled person should not use the machine without a qualified person or physician in attendance.
10. Before using the machine to exercise, always do stretching exercises to properly warm up.
11. Never operate the machine if the machine is not functioning properly.
12. A spotter is recommended during exercise.
13. Do not intend to insert weight selector pin while the weight stack or top plate is in elevated position.
14. Be certain the weight Selector Pin is completely inserted.
15. Never use dumbbells or other means to increase the weight resistance. Use only weight plates provided by manufacturer.
16. This machine is designed and intended for home and consumer use only, not for commercial use

CARE AND MAINTENANCE

1. Lubricate moving parts with WD-40 or light oil periodically.
2. Inspect and tighten all parts before using the machine.
3. The machine can be cleaned using a damp cloth and mild non-abrasive detergent. DO NOT use solvents.
4. Maximum user's weight: 300 lbs.

WARNING: BEFORE BEGINNING ANY EXERCISE PROGRAM, CONSULT YOUR PHYSICIAN. THIS IS ESPECIALLY IMPORTANT FOR INDIVIDUALS OVER THE AGE OF 35 OR PERSONS WITH PRE-EXISTING HEALTH PROBLEMS. READ ALL INSTRUCTIONS BEFORE USING ANY FITNESS EQUIPMENT. IMPEX INC. ASSUMES NO RESPONSIBILITY FOR PERSONAL INJURY OR PROPERTY DAMAGE SUSTAINED BY OR THROUGH THE USE OF THIS PRODUCT.

SAVE THESE INSTRUCTIONS.

WARNING LABEL PLACEMENT

⚠ WARNING
SERIOUS INJURY MAY OCCUR
Do not attempt to exercise or hang from the lat bar while it is placed or stored on the storage hooks

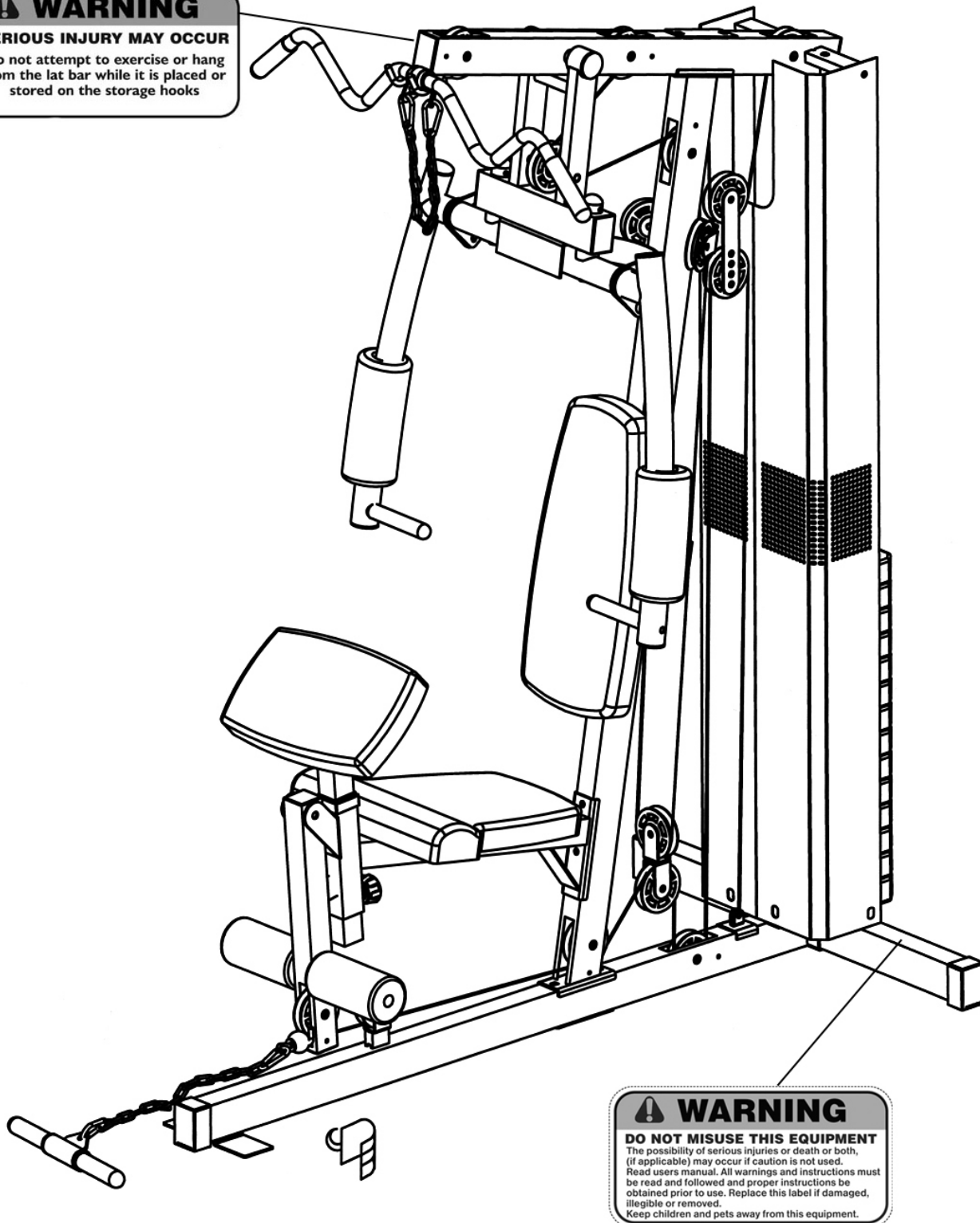

⚠ WARNING
DO NOT MISUSE THIS EQUIPMENT
The possibility of serious injuries or death or both, (if applicable) may occur if caution is not used. Read users manual. All warnings and instructions must be read and followed and proper instructions be obtained prior to use. Replace this label if damaged, illegible or removed. Keep children and pets away from this equipment.

The warning labels shown here have been placed on the Rear Base Frame and Upper Frame. If the labels are missing or illegible, please call customer service at 1-800-888-8899 for replacements. Apply the labels in the location shown.

HARDWARE PACK

NOTE: The following parts are not drawn to scale. Please use your own ruler to measure the size.

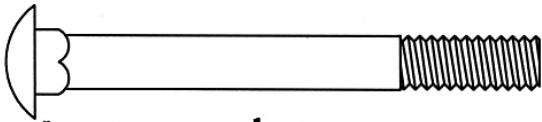

#78 M10 x 3 1/2" Carriage Bolt (Qty 4)

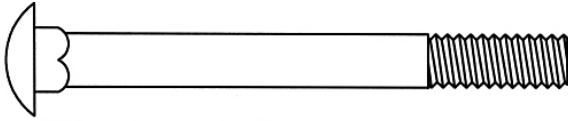

#79 M10 x 3 3/4" Carriage Bolt (Qty 2)

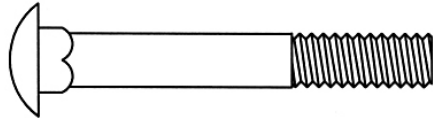

#80 M10 x 2 3/4" Carriage Bolt (Qty 2)

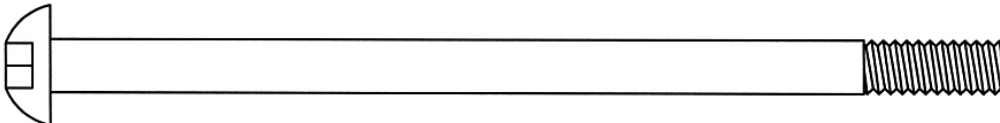

#97 M10 x 6 3/4" Allen Bolt (Qty 1)

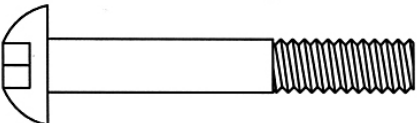

#69 M10 x 2 1/2" Allen Bolt (Qty 7)

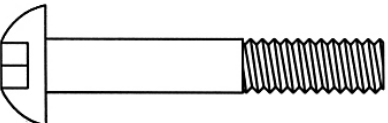

#70 M10 x 2 3/8" Allen Bolt (Qty 2)

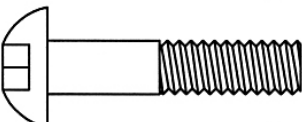

#71 M10 x 1 3/4" Allen Bolt (Qty 7)

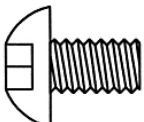

#72 M10 x 5/8" Allen Bolt (Qty 6)

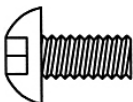

#76 M8 x 5/8" Allen Bolt (Qty 4)

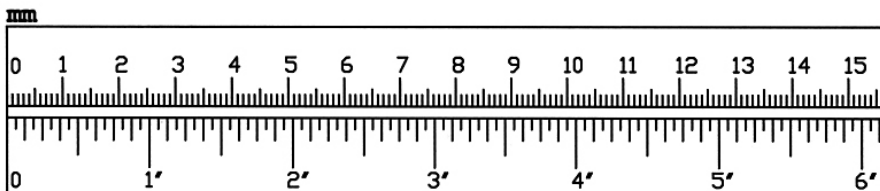

HARDWARE PACK

NOTE: The following parts are not drawn to scale. Please use your own ruler to measure the size.

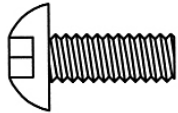

#73 M10 x 1" Allen Bolt (Qty 9)

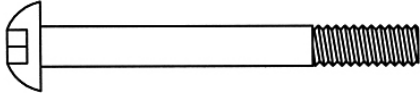

#74 M8 x 3" Allen Bolt (Qty 2)

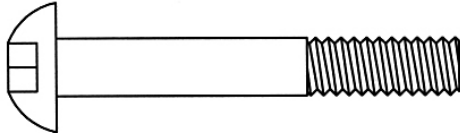

#81 M12 x 3 1/8" Allen Bolt (Qty 1)

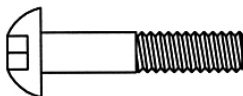

#75 M8 x 1 5/8" Allen Bolt (Qty 2)



#77 M6 x 1 1/4" Allen Bolt (Qty 2)



#82 M5 x 3/8" Philips Screw (Qty 3)

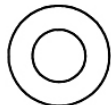

#84 \varnothing 3/4" Washer
(Qty 44)

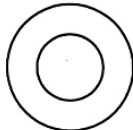

#85 \varnothing 1" Washer
(Qty 2)



#86 \varnothing 5/8" Washer
(Qty 8)

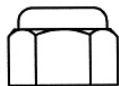

#91 M12 Aircraft Nut
(Qty 1)



#89 M6 Aircraft Nut
(Qty 4)



#90 M5 Aircraft Nut
(Qty 3)



#83 M10 Aircraft Nut
(Qty 26)



#88 \varnothing 3/4" Lock Washer
(Qty 2)

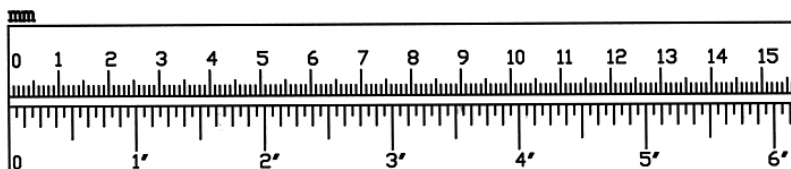

HARDWARE PACK

NOTE: The following parts are not drawn to scale. Please use your own ruler to measure the size.

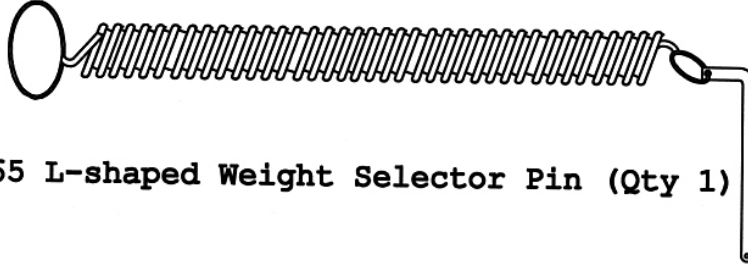

#65 L-shaped Weight Selector Pin (Qty 1)

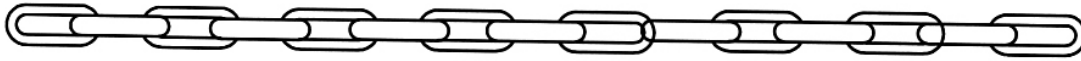

#66 Chain (Qty 2)

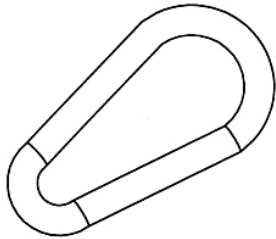

#67 Hook (Qty 4)



#35 \varnothing 1" x $\frac{3}{8}$ " Leg Developer Bushing (Qty 2)

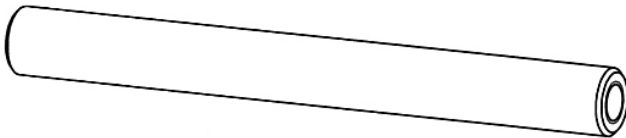

#37 6 $\frac{1}{8}$ " Axle (Qty 1)

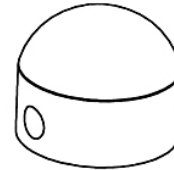

#52 Lock Ring (Qty 2)

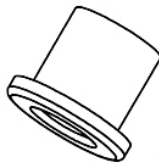

#44 \varnothing $\frac{7}{8}$ " x $\frac{5}{8}$ " Pulley Bushing (Qty 10)

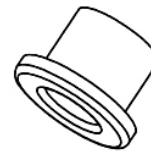

#45 \varnothing $\frac{7}{8}$ " x $\frac{1}{2}$ " Pulley Bushing (Qty 4)

ASSEMBLY INSTRUCTION

Tools Required for Assembling the Machine: Two Adjustable Wrenches, two Allen Wrenches, and one Philips Screwdriver. NOTE: It is strongly recommended this machine to be assembled by two or more people to avoid possible injury.

STEP 1 (See Diagram 1)

- A.) Push two $\text{Ø } 2 \frac{3}{8}'' \times 1''$ Rubber Bumpers (#43) onto the Guide Rods (#13) from the bottom. Insert the Guide Rods into the holes on the Rear Base Frame (#2). **The Guide Rods have holes on the rods about 2/3 way down the rods: for locking the weight stack when not in use. The shorter end of the Guide Rod with the lock holes need to be pointed downwards towards the Rear Base Frame.**
- B.) Secure them with two M10 x 1" Allen Bolts (#73) and two $\text{Ø } \frac{3}{4}''$ Washers (#84) from the bottom of the Rear Base Frame.
- C.) **Do not tighten Nuts and Bolts starting from next step until instructed to do so.**
- D.) Attach the Front Vertical Frame (#3) to the Base Frame (#5). Secure it with two M10 x 3 $\frac{1}{2}''$ Carriage Bolts (#78), one 5 $\frac{1}{2}'' \times 2''$ Bracket (#21), two $\text{Ø } \frac{3}{4}''$ Washers (#84), and two M10 Aircraft Nuts (#83) from bottom.
- E.) Connect the Base Frame to the Rear Base Frame (#2). Secure it with two M10 x 2 $\frac{3}{4}''$ Carriage Bolts (#80), one 4 $\frac{3}{8}'' \times 3''$ Bracket (#29), two $\text{Ø } \frac{3}{4}''$ Washers (#84), and two M10 Aircraft Nuts (#83).

DIAGRAM 1

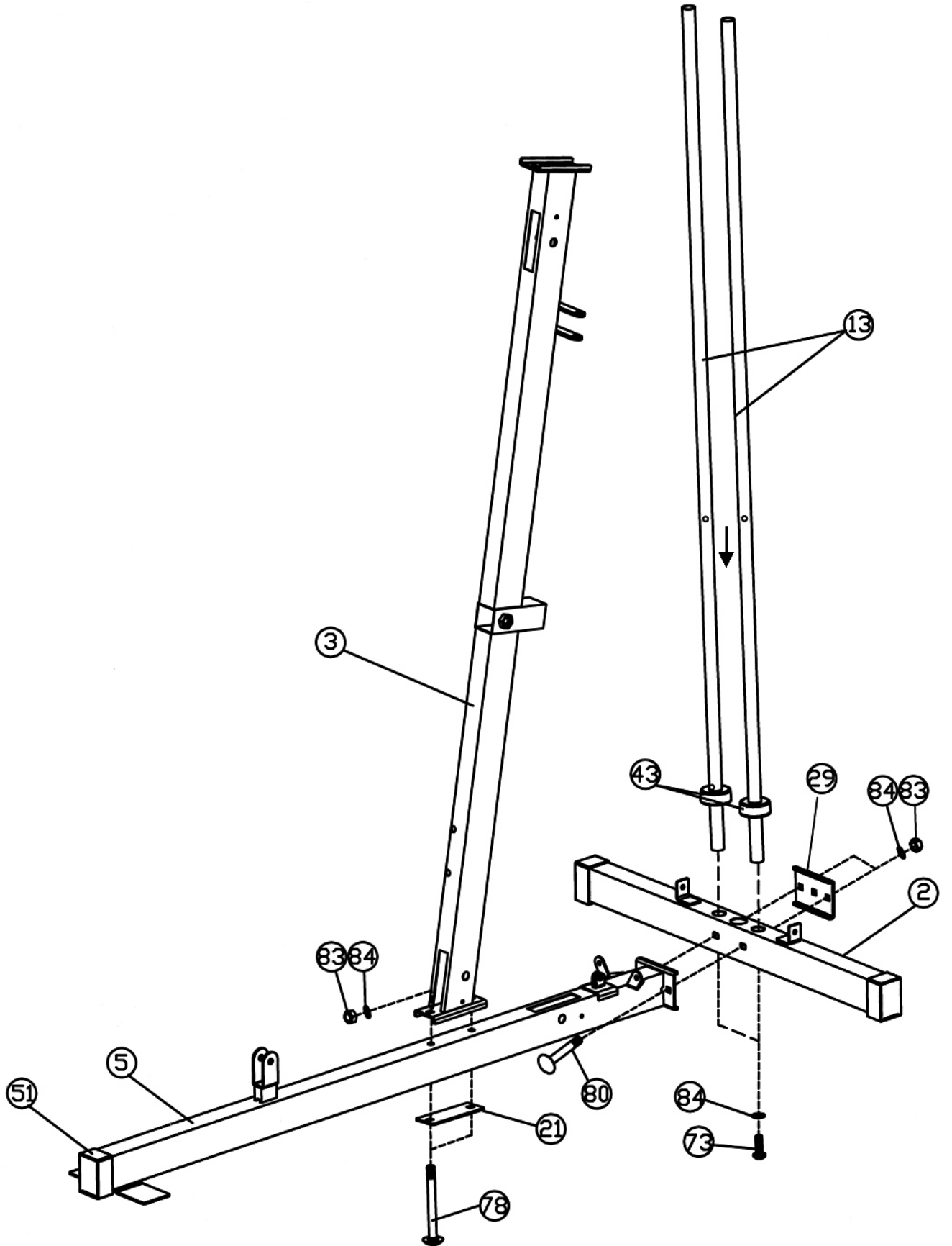

STEP 2 (See Diagram 2)

- A.) **Do not tighten Nuts and Bolts until instructed to do so.**
- B.) Slide the 14 Weight Plates (#34) onto the Guide Rods (#13). **Make sure the deep grooves on the Plates are all facing down and toward back of the machine. If the locking holes on the guide rods are more than 2-3 inches from the upper most, then you have installed the Guide Rods upside down.** Align the holes of the Weight Plates. Insert the Selector Rod (#14) through the center hole. Slide the ring on the L-shaped Weight Selector Pin (#65) onto the Selector Rod. Use the L-shaped Weight Selector Pin to select the number of Plates to exercise. **Please refer Weight Resistance Chart in page 24.**
- C.) Slide the Selector Stem (#33) onto the Guide Rods.
- D.) Attach the Upper Frame (#4) to the two Guide Rods. Place the Upper Frame onto the Front Vertical Frame (#3).
- E.) Secure the Upper Frame to the Guide Rods with two M10 x 1" Allen Bolts (#73) and two \emptyset $\frac{3}{4}$ " Washers (#84).
- F.) Secure the Upper Frame to the Front Vertical Frame with two M10 x 3 $\frac{1}{2}$ " Carriage Bolts (#78), one 5 $\frac{1}{2}$ " x 2" Bracket (#21), two \emptyset $\frac{3}{4}$ " Washers (#84), and two M10 Aircraft Nuts (#83).
- G.) **Securely tighten all Nuts and Bolts previously installed in Step-1 and Step-2.**

DIAGRAM 2

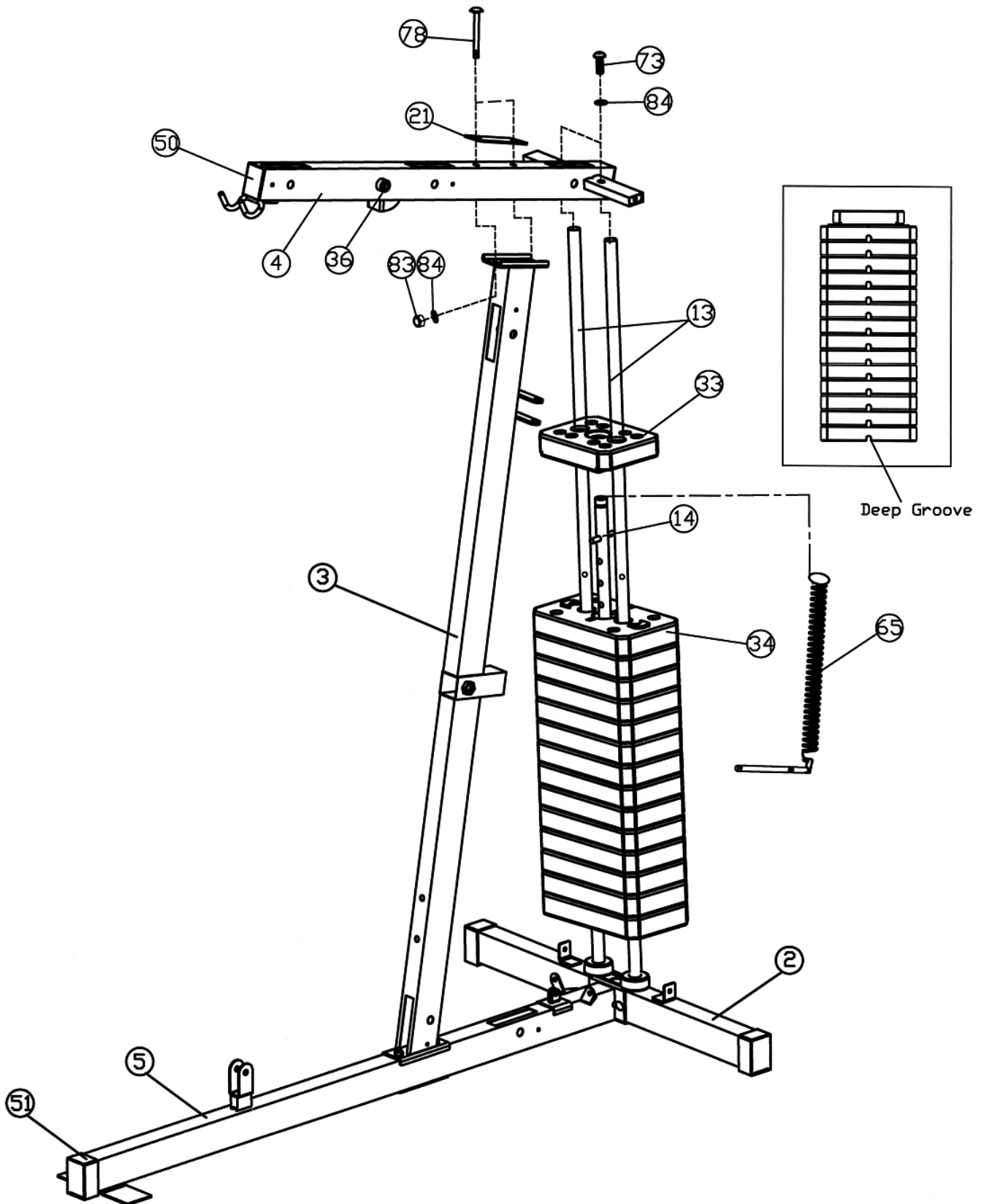

STEP 3 (See Diagram 3)

- A.) Attach the Front Press Base (#6) to the Upper Frame (#4). Secure it with one 6 1/8" Front Press Axle (#37), one $\text{\O} \frac{3}{4}$ " Washer (#84), one $\text{\O} \frac{3}{4}$ " Lock Washer (#88), one M10 x 1" Allen Bolt (#73), and one $\text{\O} 2$ " End Cap (#47) on each end of the Axle.
- B.) Insert the axle on the Right Butterfly Base (#7) into the Front Press Base from bottom. Slide a Lock Ring (#52) onto the Axle. Align the holes. Secure it with one M6 x 1 $\frac{3}{4}$ " Allen Bolt (#77) and M6 Aircraft Nut (#89).
- C.) Attach the Right Butterfly (#9) to the Front Press Adjustment Frame (#31) on the Right Butterfly Base. Insert a M8 x $\frac{3}{4}$ " Allen Bolt (#92) through Right Butterfly to the open track on the Adjustment Frame (#31). Secure the Bolt with one $\text{\O} \frac{1}{2}$ " Washer (#87) and one M6 Aircraft Nut (#89). **Do not over tighten the Nut. Make sure the Bolt can travel along the track freely.**
- D.) Rotate the Right Butterfly and thread a M18 Quick Release Lock Pin (#55) into the selected hole on Front Press Adjustment Frame to obtain desired Front Press position.
- E.) Slide a Butterfly Large Foam Roll (#63) onto the Right Butterfly arm. Attach a Front Press Handle (#30) to the Right Butterfly. Secure it with a M10 x 1" Allen Bolt (#73) and $\text{\O} \frac{3}{4}$ " Washer (#84).
- F.) Repeat B to E above to install the Left Butterfly Base (#8) and Left Butterfly (#10).
- G.) Attach a Swivel Pulley Brackets (#26) to an open pulley bracket on the back of Front Vertical Frame (#3). Secure it with one M10 x 2 $\frac{1}{2}$ " Allen Bolt (#69), two $\text{\O} \frac{3}{4}$ " Washers (#84), and one M10 Aircraft Nut (#83). Repeat the same step to install the other Swivel Pulley Bracket on the other side.
- H.) Attach the Backrest Board (#39) to the Backrest Board Support Frame (#24). Secure it with two M8 x 1 $\frac{5}{8}$ " Allen Bolts (#75) and two $\text{\O} \frac{5}{8}$ " Washers (#86). Insert the Support Frame into the open slot on Front Vertical Frame. Use a M18 Lock Knob (#54) lock the Support Frame at selected position.

DIAGRAM 3

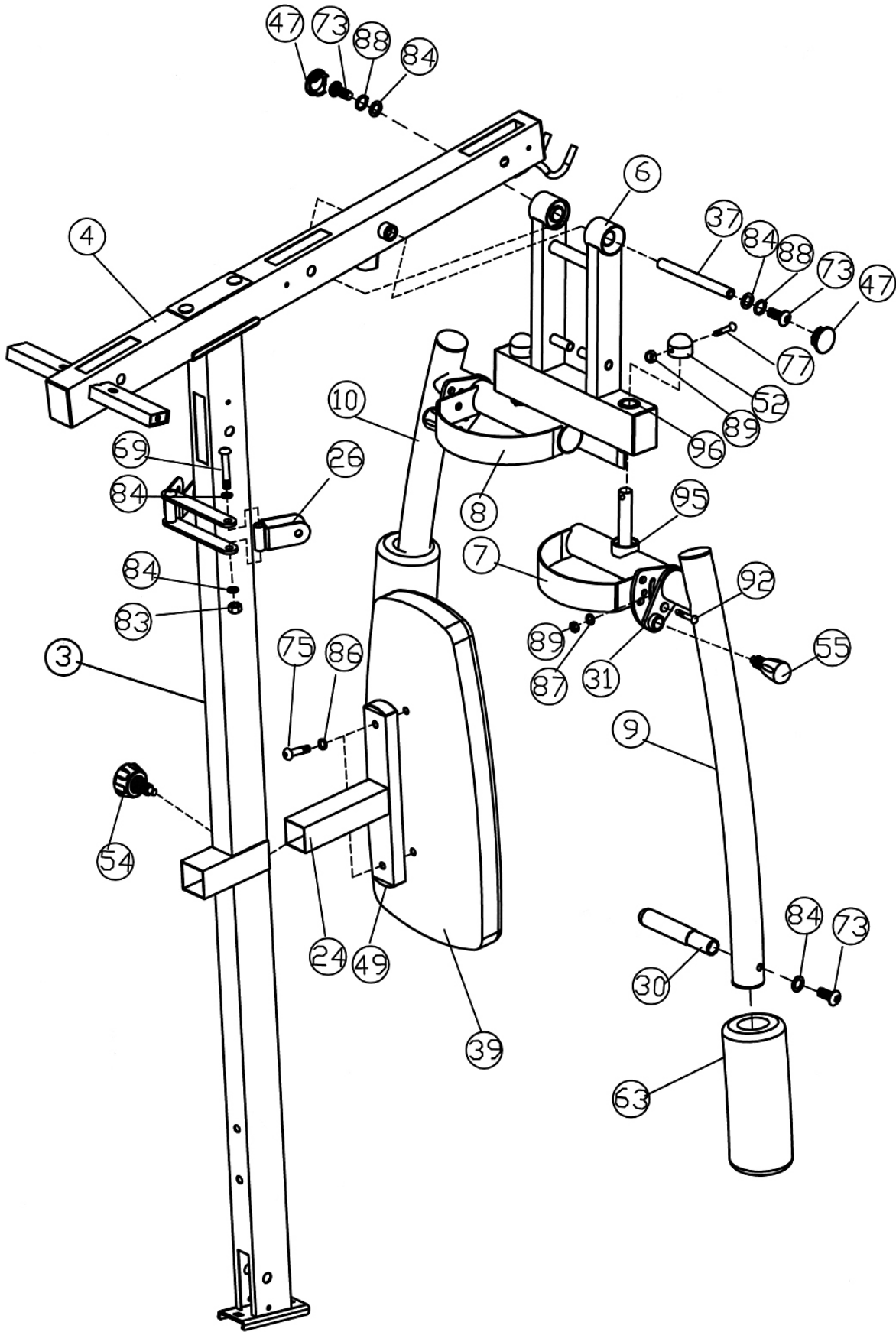

STEP 4 (See Diagram 4)

- A.) Attach the Main Seat Support (#1) to the Front Vertical Frame (#3). Secure it with two M10 x 3 3/4" Carriage Bolts (#79), one 4 3/4" x 1 3/4" Bracket (#22), two Ø 3/4" Washers (#84), and two M10 Aircraft Nuts (#83).
- B.) Attach the Seat Bracket (#20) onto the Main Seat Support. Place the Seat Pad (#38) onto Main Seat Support and Seat Bracket. Secure it with two M8 x 3" Allen Bolts (#74), two M8 x 5/8" Allen Bolts (#76), and four Ø 5/8" Washers (#86).
- C.) Attach the Leg Developer (#11) to the open bracket on the Main Seat Support. Secure it with one M12 x 3 1/8" Allen Bolt (#81), two Ø 1" Washers (#85), and one M12 Aircraft Nut (#91).
- D.) Insert the Foam Tube (#28) halfway through the holes on the Leg Developer. Push two Foam Rolls (#64) onto the Foam Tube from both ends.
- E.) Attach the Arm Curl Pad (#40) to the Arm Curl Stand (#12). Secure it with two M8 x 5/8" Allen bolts (#76) and two Ø 5/8" Washers (#86). Insert the Arm Curl Stand into the front opening on the Main Seat Support. Use a M18 Lock Knob (#54) to lock the Arm Curl Stand in position.

DIAGRAM 4

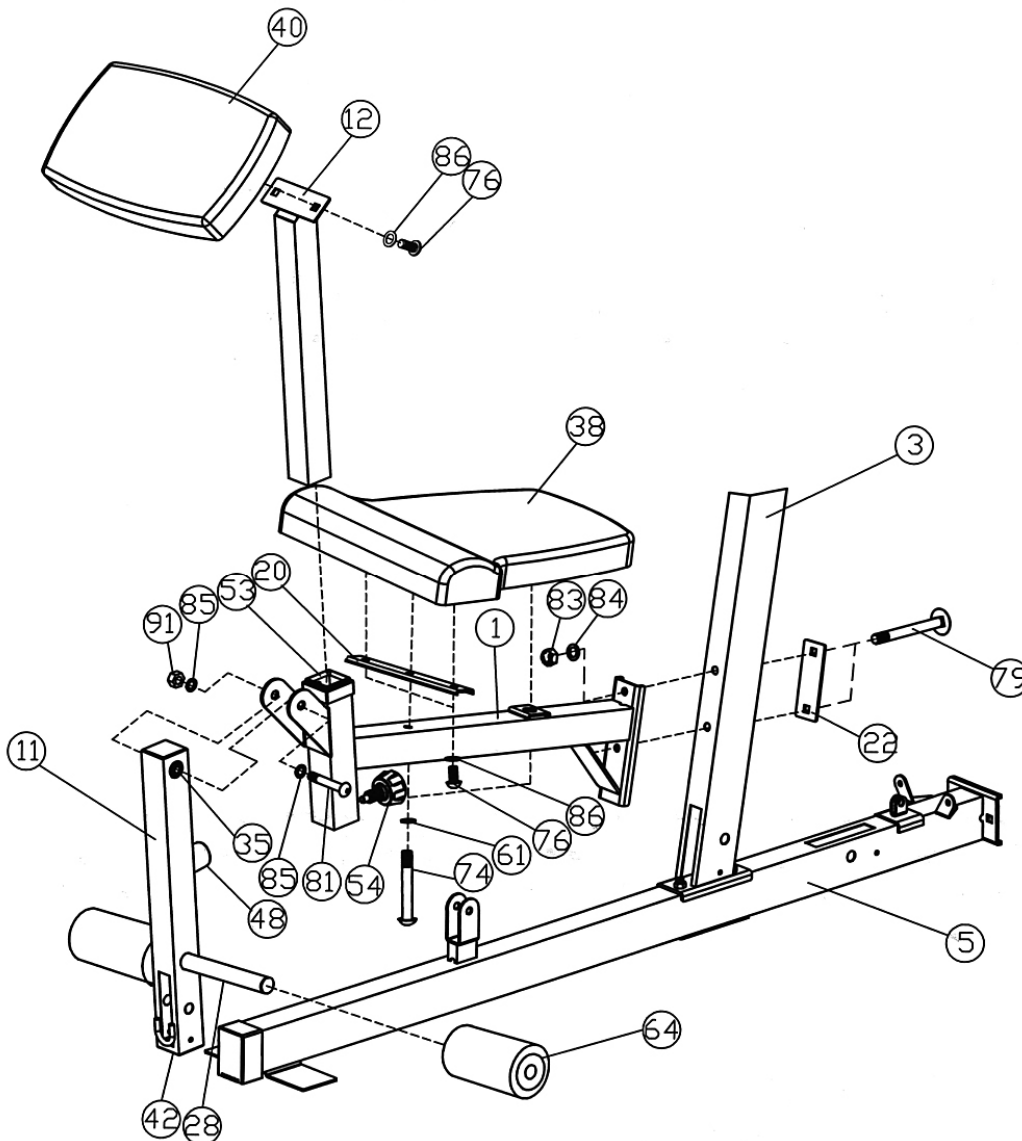

CABLE LOOP DIAGRAM

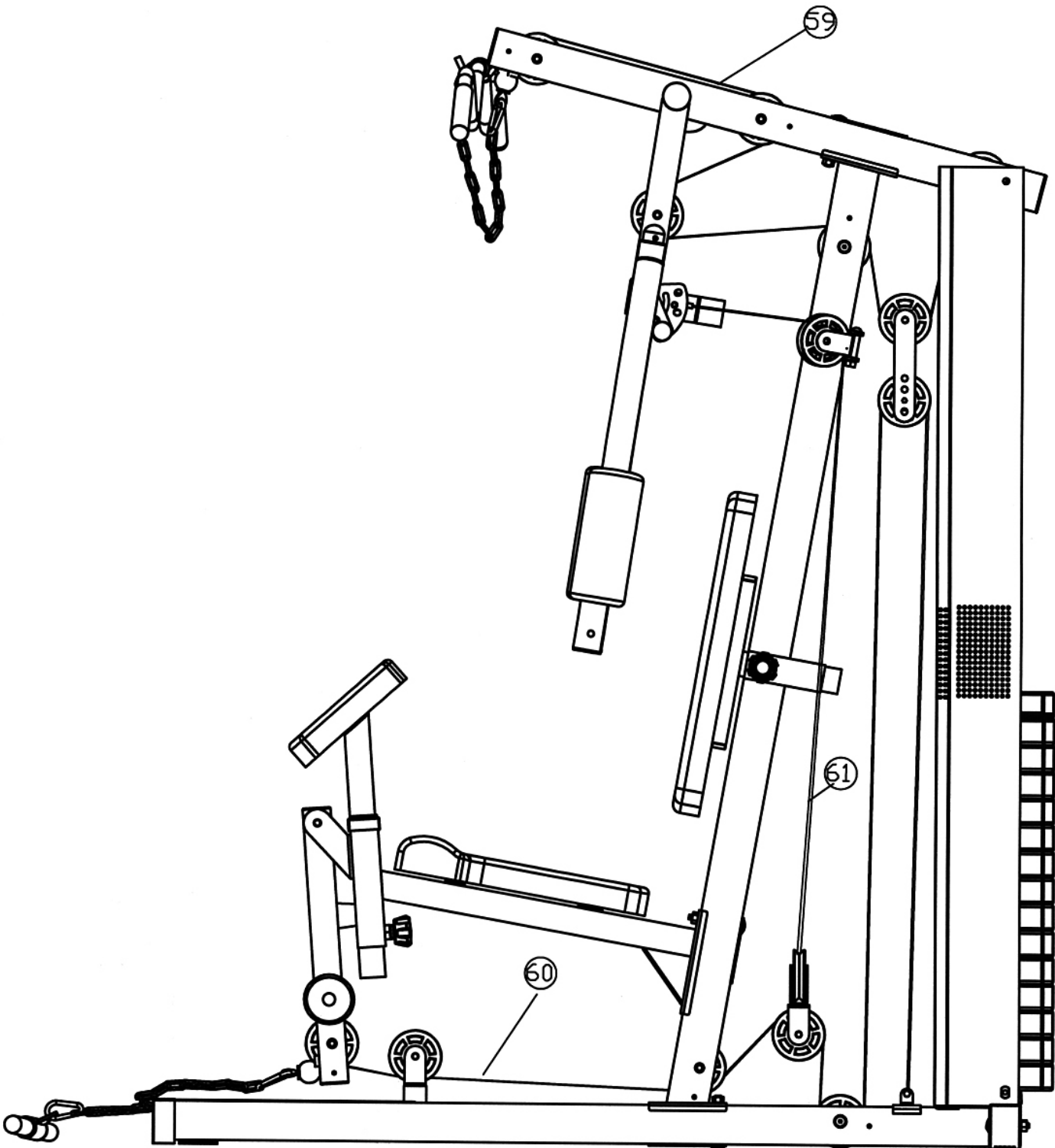

STEP 5 (See Diagram 5 & Cable Loop Diagram)

- A.) Attach the 118" Upper Cable (#59) to the opening on the front of the Upper Frame (#4). **Note:** The Ball Stopper on the cable should be underneath the Frame.
- B.) Attach a Pulley (#62) to the opening. Secure it with one M10 x 2 ½" Allen Bolt (#69), two Ø 7/8" x 5/8" Pulley Bushings (#44), and one M10 Aircraft Nut (#83).
- C.) Draw the Cable over the Pulley towards the back of the machine to the second opening on the Upper Frame. Repeat step B above to install a Pulley.
- D.) Draw the Cable around the Pulley then pull back to the opening on the Front Press Base (#6).
- E.) Attach a Pulley to the opening on the Front Press Base. Secure the Pulley with one M10 x 6 ¾" Allen Bolt (#97), two Ø ¾" Washers (#84), and one M10 Aircraft Nut (#83).
- F.) Draw the Cable around the Pulley and then to the opening on the Front Vertical Frame (#3). Attach a Pulley to the opening. Secure it with one M10 x 2 3/8" Allen Bolt (#70), two Ø 7/8" x ½" Pulley Bushings (#45), and one M10 Aircraft Nut (#83).
- G.) Draw the Cable around the Pulley then pull the Cable downwards. Attach the Cable to two Double Floating Pulley Brackets (#23). Attach a Pulley and a L-shaped Cable Retainer (#27) to the top holes on the Brackets. Secure them with one M10 x 1 ¾" Allen Bolts (#71), two Ø ¾" Washers (#84), and one M10 Aircraft Nut (#83). Let the Brackets hanging just for now.
- H.) Pull the Cable upward to the opening on the rear of Upper Frame. Repeat B to install a Pulley.
- I.) Pull the Cable downward between the two Guide Rods to the Selector Rod (#14). Thread the bolt at the end of the Cable into the opening on top of the Selector Rod to secure the Cable.
- J.) Connect a Chain (#66) to the Cable with a Hook (#67). Connect the Lat Bar to the Chain with another Hook. Change the length of the Chain to the Cable to obtain the desired Lat Bar exercises.

DIAGRAM 5

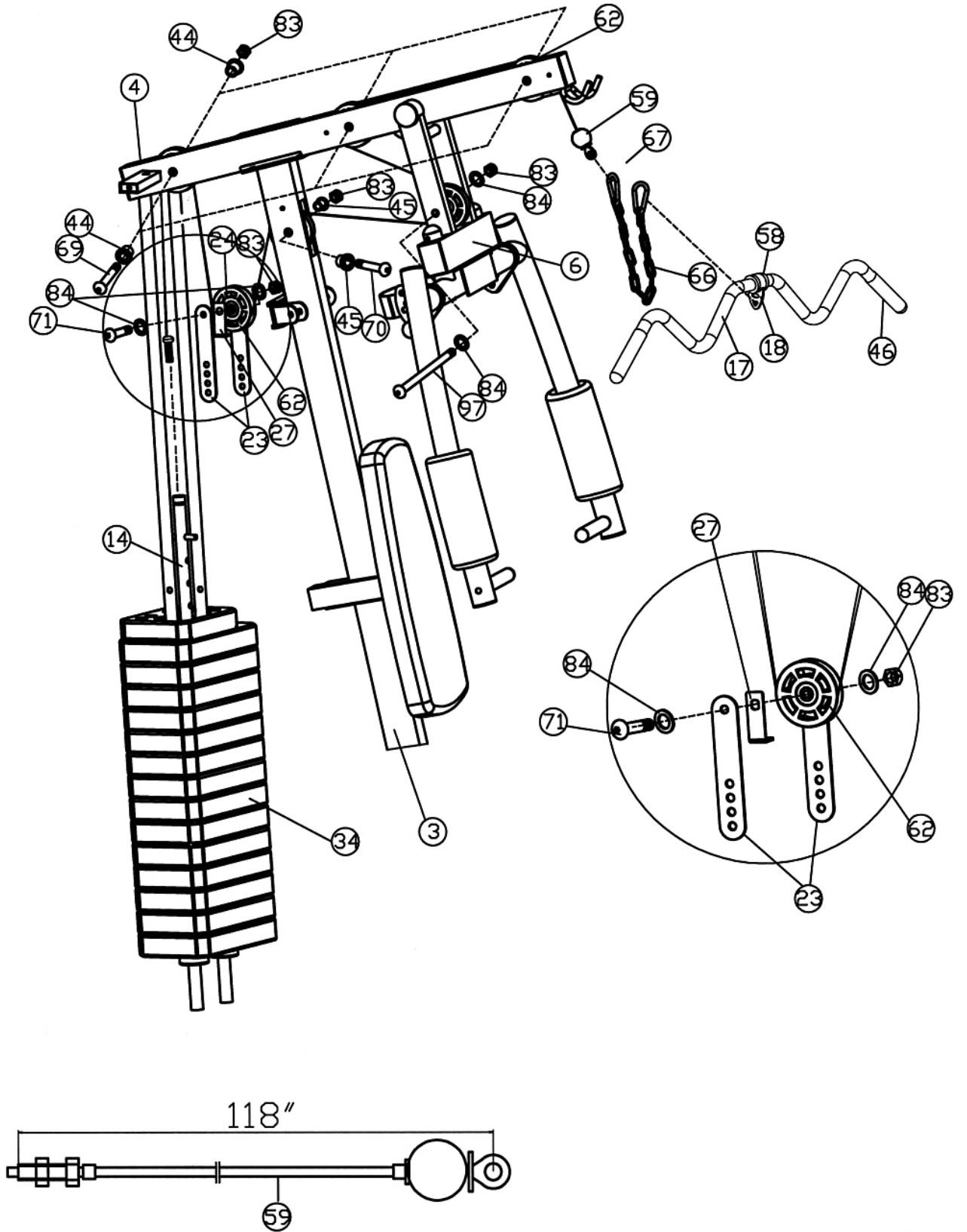

STEP 6 (See Diagram 6 & Cable Loop Diagram)

- A.) Attach one end of the 110" Butterfly Cable (#61) onto the hook on the Right Butterfly Base (#7).
- B.) Draw the Cable to the right Swivel Pulley Bracket (#26).
- C.) Attach a Pulley to the bracket. Secure it with one M10 x 1 3/4" Allen Bolt (#71), two Ø 3/4" Washers (#84), and one M10 Aircraft Nut (#83).
- D.) Draw the Cable around the Pulley then downward. Attach the Cable to an Angled Floating Pulley Bracket (#25). Repeat C to install another Pulley. Let the Bracket hang for now.
- E.) Pull the Cable around the Pulley then upward to the left Swivel Pulley Bracket. Repeat Step C above to install a Pulley.
- F.) Draw the Cable to the Left Butterfly Base (#8). Repeat A to secure the end of the Cable to the Left Butterfly Base.

DIAGRAM 6

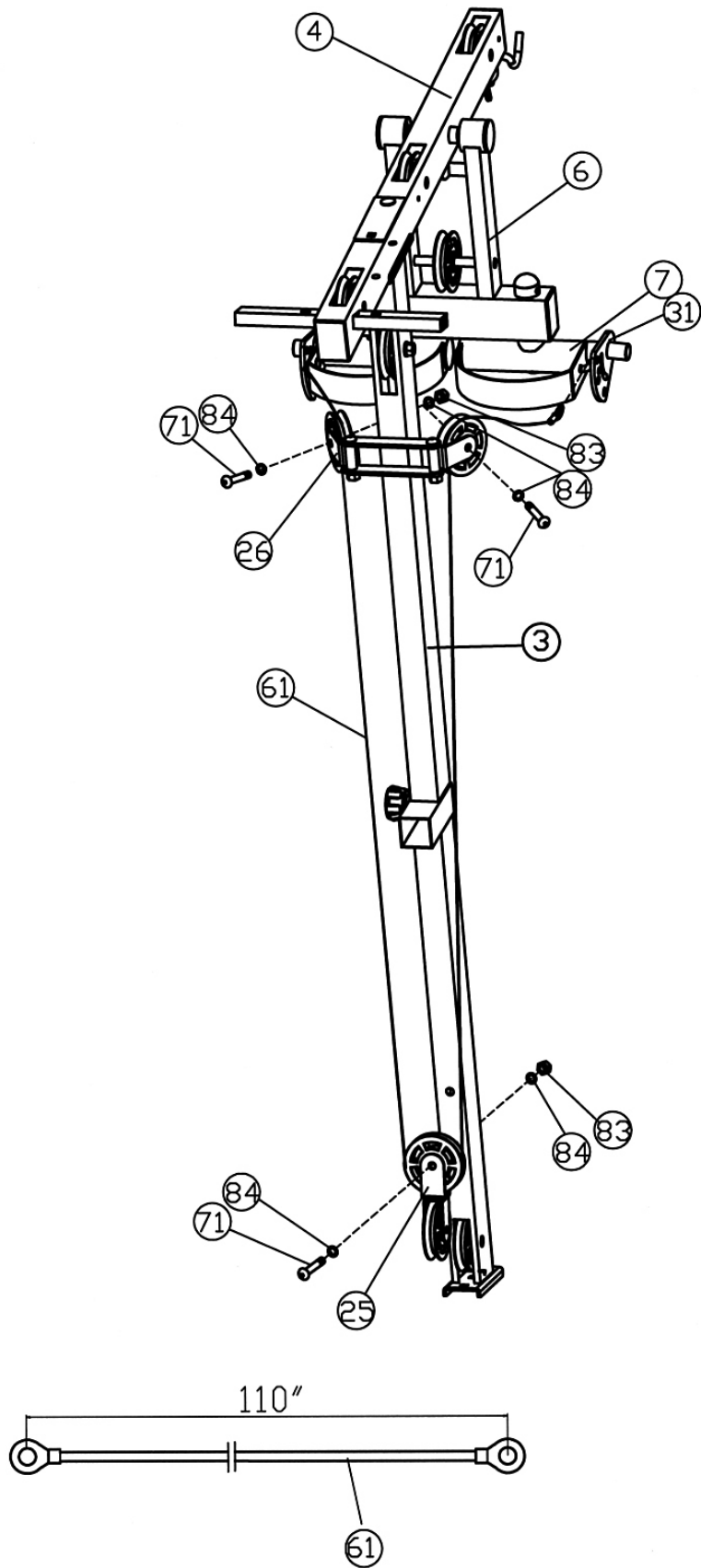

STEP 7 (See Diagram 7 & Cable Loop Diagram)

- A.) Attach the 157" Lower Cable (#60) to the opening on the bottom of the Leg Developer (#11).
- B.) Attach a Pulley (#62) to the opening. Secure it with one M10 x 2 ½" Allen Bolt (#69), two Ø 7/8" x Ø 5/8" Bushings (#44), and one M10 Aircraft Nut (#83).
- C.) Draw the Cable underneath the Pulley to the open bracket on Base Frame (#5).
- D.) Attach a Pulley to the bracket. Secure it with one M10 x 1 ¾" Allen Bolt (#71), two Ø ¾" Washers (#84), and one M10 Aircraft Nut (#83).
- E.) Draw the Cable underneath the Pulley to the opening on the bottom of Front Vertical Frame (#3). Attach a Pulley to the opening. Secure it with one M10 x 2 3/8" Allen Bolt (#70), two Ø 7/8" x ½" Pulley Bushings (#45), and one M10 Aircraft Nut (#83).
- F.) Draw the Cable underneath the Pulley then pull the Cable upward to the Angled Floating Pulley Bracket (#25) previously installed in Step-6. Repeat D to install a Pulley.
- G.) Draw the Cable around the Pulley then downward to the opening on the Base Frame (#5). Repeat B to install another Pulley.
- H.) Pull the Cable around the Pulley then upward to the Double Floating Pulley Bracket (#23) previously installed in Step-5. Repeat D to install a Pulley with a L-shaped Cable Retainer. Adjust the Cable tension by adjusting this Pulley position on the Brackets. If the tension is too tight then move the Pulley down by one hole. If the tension is too loose then move up one hole.
- I.) Draw the Cable around the Pulley then pull downward. Attach end of the Cable to a bracket on the Base Frame. Secure it with one M10 x 1" Allen Bolt (#73), two Ø ¾" Washers (#84), and one M10 Aircraft Nut (#83).

DIAGRAM 7

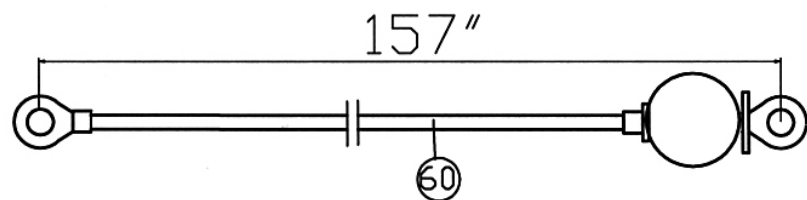
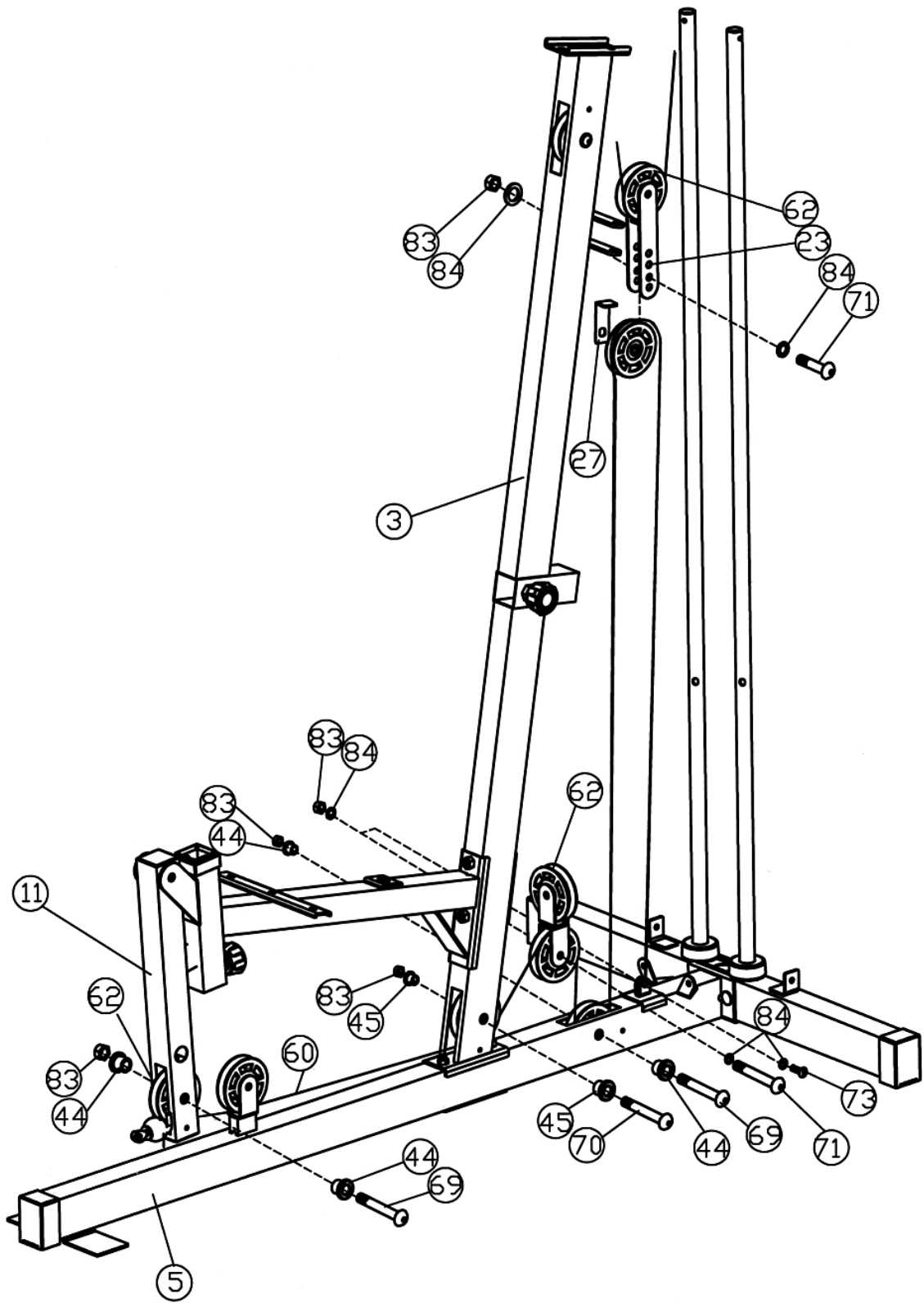

STEP 8 (See Diagram 8)

- A.) Attach a Chain (#66) to the Lower Cable (#60) by using a Hook (#67). Attach the Shiver Bar Handle (#19) to the Chain by using another Hook. Adjust the length of the Chain to obtain the desired Arm Curl exercise. Replace Shiver Bar Handle with Ankle Strap (#68) for various exercises. Remove the Chain and Shiver Bar Handle when using the Leg Developer.
- B.) Attach Right & Left Weight Stack Covers (#15 & #16) to the Upper Frame (#4), Base Frame (#5), and Rear Base Frame (#2). Secure them with six M10 x 5/8" Allen Bolts (#72) and \varnothing 3/4" Washers (#84).
- C.) From the back of the Covers, secure the two covers together with three M5 x 3/8" Philips Screws (#82) and three M5 Aircraft Nuts (#90).
- D.) Insert a L-shaped Lock Pin (#93) through the hole on Guide Rod and lock with a Combination Lock (#98) to prevent any un-authorized usage of the machine.
- E.) Unlock the Lock and attach it to Selector Rod before using the machine.

DIAGRAM 8

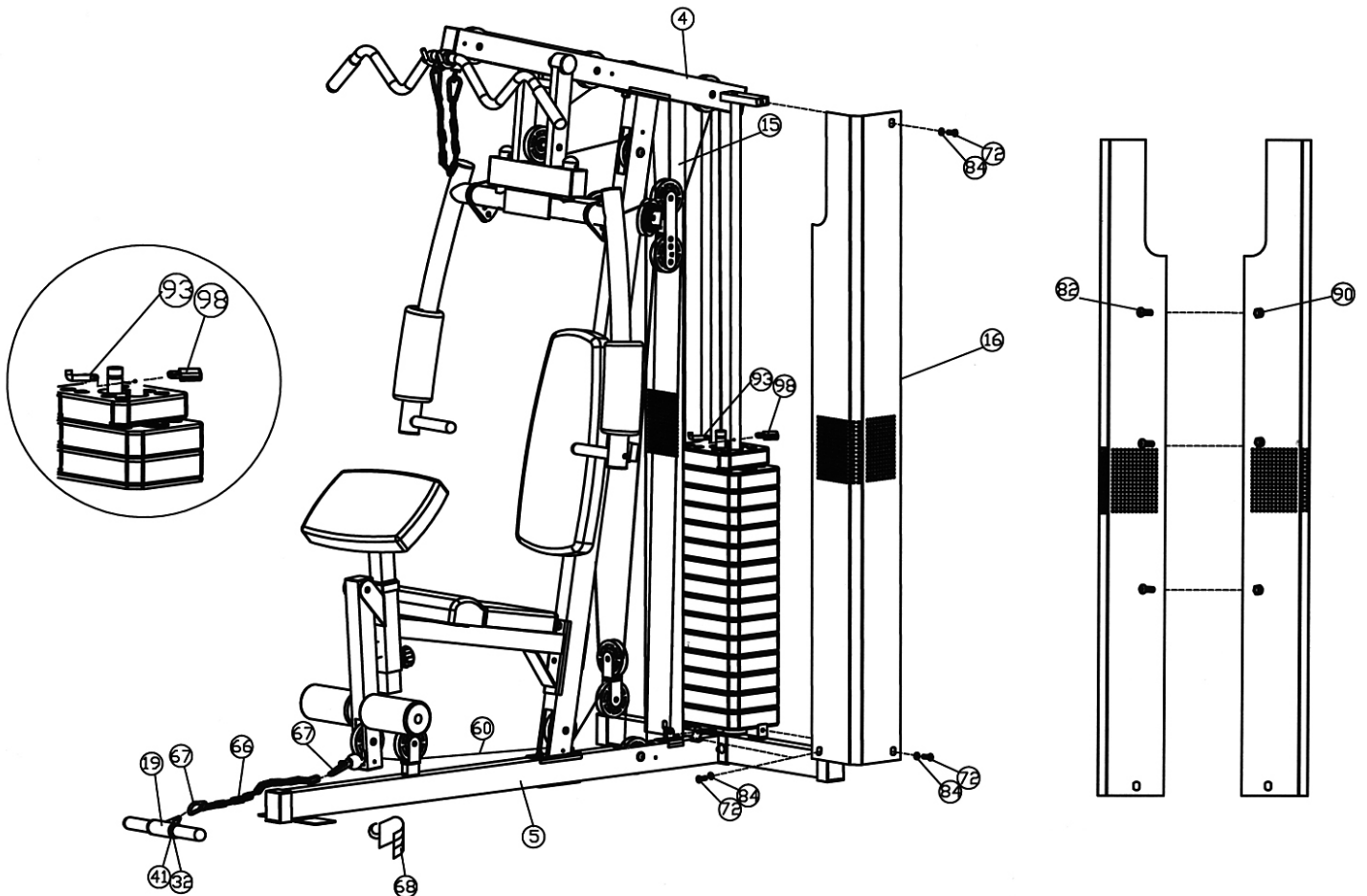

Set up the Lock Combination

- A.) The combination is pre-set at 0-0-0 by the factory.
- B.) Turn the dials to 0-0-0 and aligned to the Combination Set Up Line.
- C.) Pull out the shackle and turn 180°.
- D.) Press down on the shackle.
- E.) Turn the dials (aligned to the Combination Set Up Line) to your desired combination.
- F.) Pull out the shackle and twist back to normal position and the combination are set.
- G.) Repeat Procedure C to F to re-set the combination.

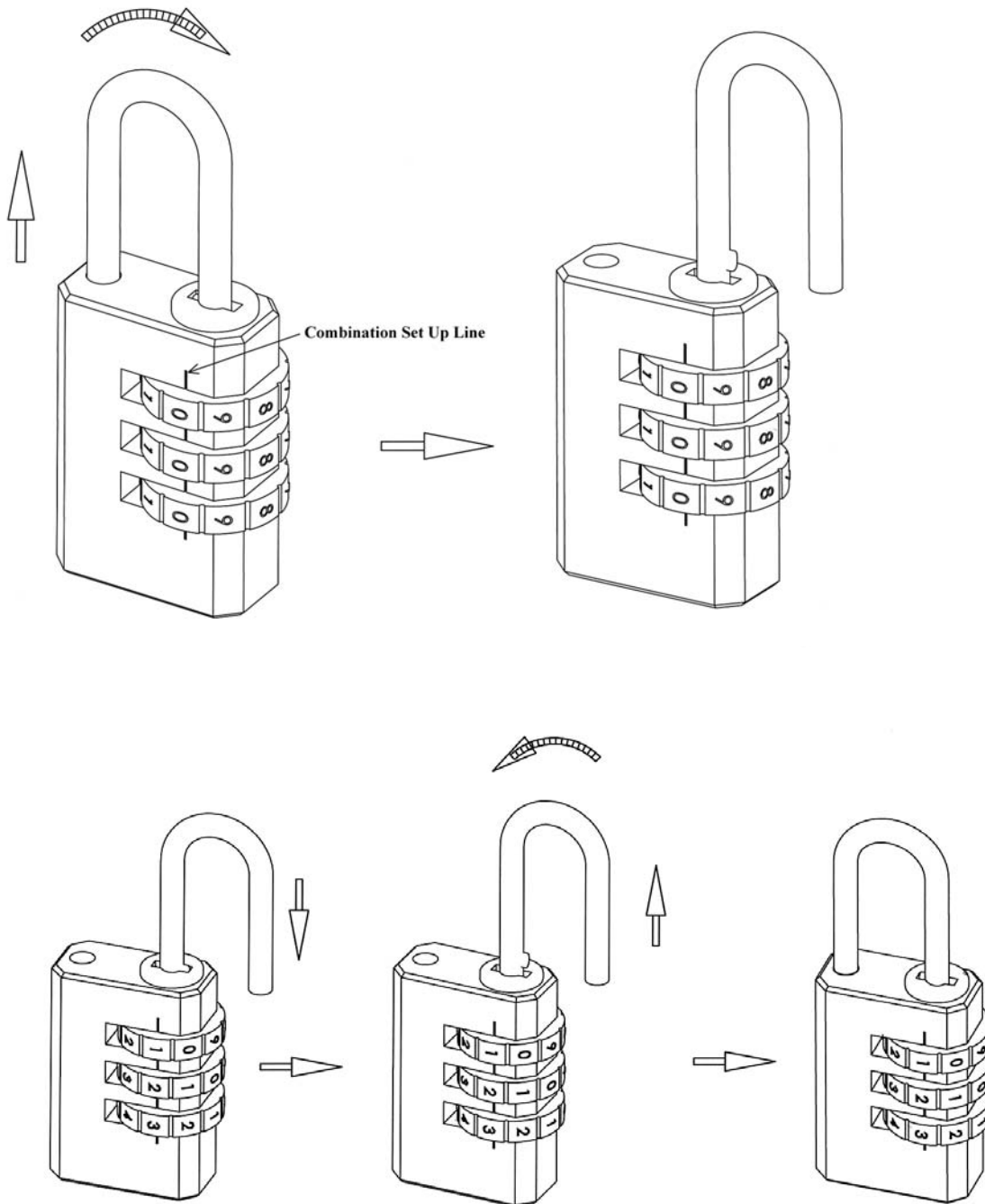

PARTS LIST

KEY NO.	DESCRIPTION	Q'ty			
			51	2" x 2 3/4" End Cap	3
1	Main Seat Support	1	52	Lock Ring	2
2	Rear Base Frame	1	53	2" Sleeve	1
3	Front Vertical Frame	1	54	M18 Lock Knob	2
4	Upper Frame	1	55	M18 Quick Release Lock Pin	2
5	Base Frame	1	56	Ø 1" Cone-shaped End Cap	1
6	Front Press Base	1	57	Ø 1" End Cap	2
7	Right Butterfly Base	1	58	Plastic Ring	2
8	Left Butterfly Base	1	59	118" Upper Cable	1
9	Right Butterfly	1	60	157" Lower Cable	1
10	Left Butterfly	1	61	110" Butterfly Cable	1
11	Leg Developer	1	62	Pulley	15
12	Arm Curl Stand	1	63	Butterfly Large Foam Roll	2
13	Guide Rod	2	64	Foam Roll	2
14	Selector Rod	1	65	L-shaped Weight Selector Pin	1
15	Right Weight Stack Cover	1	66	Chain	2
16	Left Weight Stack Cover	1	67	Hook	4
17	Lat Bar	1	68	Ankle Strap	1
18	Rotate Ring	1	69	M10 x 2 1/2" Allen Bolt	7
19	Shiver Bar Handle	1	70	M10 x 2 3/8" Allen Bolt	2
20	Seat Bracket	1	71	M10 x 1 3/4" Allen Bolt	7
21	5 1/2" x 2" Bracket	2	72	M10 x 5/8" Allen Bolt	6
22	4 3/4" x 1 3/4" Bracket	1	73	M10 x 1" Allen Bolt	9
23	Double Floating Pulley Bracket	2	74	M8 x 3" Allen Bolt	2
24	Backrest Board Support Frame	1	75	M8 x 1 5/8" Allen Bolt	2
25	Angled Floating Pulley Bracket	1	76	M8 x 5/8" Allen Bolt	4
26	Swivel Pulley Bracket	2	77	M6 1 1/4" Allen Bolt	2
27	L-shaped Cable Retainer	2	78	M10 x 3 1/2" Carriage Bolt	4
28	Foam Tube	1	79	M10 x 3 3/4" Carriage Bolt	2
29	4 3/8" x 3" Bracket	1	80	M10 x 2 3/4" Carriage Bolt	2
30	Front Press Handle	2	81	M12 x 3 1/8" Allen Bolt	1
31	Front Press Adjustment Frame	2	82	M5 x 3/8" Philips Screw	3
32	Shiver Bar	1	83	M10 Aircraft Nut	26
33	Selector Stem	1	84	Ø 3/4" Washer	44
34	Weight Plate	14	85	Ø 1" Washer	2
35	Ø 1" x 3/8" Leg Developer Bushing	2	86	Ø 5/8" Washer	8
36	Ø 1" x Ø 5/8" Bushing	6	87	Ø 1/2" Washer	2
37	6 1/8" Front Press Axle	1	88	Ø 3/4" Lock Washer	2
38	Seat Pad	1	89	M6 Aircraft Nut	4
39	Backrest Board	1	90	M5 Aircraft Nut	3
40	Arm Curl Pad	1	91	M12 Aircraft Nut	1
41	Shiver Bar Plastic Ring	2	92	M8 x 3/4" Allen Bolt	2
42	2" Square End Cap	2	93	L-shaped Lock Pin	1
43	Ø 2 3/8" x 1" Rubber Bumper	2	94	M6 x 5/8" Philips Screw	1
44	Ø 7/8" x 5/8" Pulley Bushing	10	95	Axle Cover	2
45	Ø 7/8" x 1/2" Pulley Bushing	4	96	Ø 1 1/8" x 3 1/4" Bushing	2
46	Handle Grip	6	97	M10 x 6 3/4" Allen Bolt	1
47	Ø 2" End Cap	8	98	Combination Lock	1
48	Ø 1 3/4" x 1 5/8" Rubber Bumper	1			
49	1" x 2" End Cap	2			
50	2" x 2 3/4" Flat End Cap	4			

PM3200 WEIGHT RESISTANCE CHART

	WEIGHT PLATE								
Station	1	2	3	4	5	6	7	8	9
Front Press	30	42	54	66	78	90	102	114	126
Lat Pull	30	40	50	60	70	80	90	100	110
Butterfly	15	20	25	30	35	40	45	50	55
Low Pulley	30	40	50	60	70	80	90	100	110
Leg Developer	30	40	50	60	70	80	90	100	110

	WEIGHT PLATE								
Station	10	11	12	13	14				
Front Press	138	150	162	174	186				
Lat Pull	120	130	140	150	160				
Butterfly	60	65	70	75	80				
Low Pulley	120	130	140	150	160				
Leg Developer	120	130	140	150	160				

**Note: Each plate weights 10 lbs.
 Numbers are approximate. Actual weights may vary.
 Values for Butterfly are for each arm.**

IMPEX[®] INC.

LIMITED WARRANTY

IMPEX Inc. ("IMPEX[®]") warrants this product to be free from defects in workmanship and material, under normal use and service conditions, for a period of two years on the Frame from the date of purchase. This warranty extends only to the original purchaser. IMPEX's obligation under this Warranty is limited to replacing or repairing, at IMPEX's option.

All returns must be pre-authorized by IMPEX. Pre-authorization may be obtained by calling IMPEX Customer Service Department at 1-800-999-8899. All freights on products returned to IMPEX must be prepaid by the customer. This warranty does not extend to any product or damage to a product caused by or attributable to freight damage, abuse, misuse, improper or abnormal usage or repairs not provided by an IMPEX authorized service center or for products used for commercial or rental purposes. No other warranty beyond that specifically set forth above is authorized by IMPEX.

IMPEX is not responsible or liable for indirect, special or consequential damages arising out of or in connection with the use or performance of the product or other damages with respect to any economic loss, loss of property, loss of revenues or profits, loss of enjoyments or use, costs of removal, installation or other consequential damages or whatsoever natures. Some states do not allow the exclusion or limitation of incidental or consequential damages. Accordingly, the above limitation may not apply to you.

The warranty extended hereunder is in lieu of any and all other warranties and any implied warranties of merchantability or fitness for a particular purpose is limited in its scope and duration to the terms set forth herein. Some states do not allow limitations on how long an implied warranty lasts. Accordingly, the above limitation may not apply to you.

This warranty gives you specific legal right. You may also have other rights which vary from state to state. Register on-line at www.impex-fitness.com

IMPEX[®] INC.
14777 Don Julian
City of Industry, CA 91746

ORDERING REPLACEMENT PARTS

Replacement parts can be ordered by calling our Customer Service Department toll-free at **1-800-999-8899** during our regular business hours: Monday through Friday, 9 am until 5 pm Pacific standard time.
info@impex-fitness.com

When ordering replacement parts, always give the following information.

1. Model
2. Description of Parts
3. Part Number
4. Date of Purchase